



Finance Committee Agenda

City of Newton In City Council

Monday, September 9th, 2019

7 PM
Room 211

Items Scheduled for Discussion:

Chair's Note: Commissioner of Public Buildings Josh Morse will provide the Committee with an update on the NewCal project as required by Council Order #102-19.

#287-19 Appointment of Rosemarie Woods as the City's Treasurer/Tax Collector
HER HONOR THE MAYOR requesting approval of the appointment of Rosemarie Woods to the City's Treasurer/Tax Collector.

Referred to Programs & Services and Finance Committees

#208-19 PRESIDENT LAREDO requesting consideration of the recommendations of the special Blue Ribbon Commission regarding compensation for the Mayor, City Council, and School Committee.

Programs & Services Committee Approved; Public Hearing Closed

208-19 (A) Mayor Compensation \$155,000.00 **Approved 7-0**

208-19 (B) City Council Compensation \$15,500.00 **Approved 7-0**

208-19 (C) School Committee Compensation \$7,750.00 **Approved 7-0**

Referred to Public Facilities and Finance Committees

#291-19 **Appropriate \$70,000 to install surveillance cameras in DPW buildings**
HER HONOR THE MAYOR requesting authorization to appropriate and expend seventy thousand (\$70,000) from FY2020 Budget Reserve to install surveillance cameras at the Rumford Ave Recycling Center, Eliot Street and Craft Street yards.

Referred to Public Facilities and Finance Committees

#292-19 **Appropriate \$175,000 for a modular trailer used by Public Work employees**

The location of this meeting is accessible and reasonable accommodations will be provided to persons with disabilities who require assistance. If you need a reasonable accommodation, please contact the city of Newton's ADA Coordinator, Jini Fairley, at least two business days in advance of the meeting: jfairley@newtonma.gov or (617) 796-1253. The city's TTY/TDD direct line is: 617-796-1089. For the Telecommunications Relay Service (TRS), please dial 711.

HER HONOR THE MAYOR requesting authorization to appropriate and expend one hundred and seventy-five thousand dollars (\$175,000) from bonded indebtedness for the purchase of a modular trailer at the Rumford Avenue Recycling Center.

Referred to Public Facilities and Finance Committees

#289-19

Appropriate \$496,000 for a Vactor combination truck for sewer cleaning

HER HONOR THE MAYOR requesting authorization to appropriate and expend four hundred and ninety-six thousand dollars (\$496,000) from the Sewer Fund Surplus to purchase a Vactor combination cleaner truck to be used by Public Works Department during sewer cleaning operations.

Referred to Public Facilities and Finance Committees

#290-19

Appropriate \$315,000 for a Vacuum Street Sweeper used for street cleaning

HER HONOR THE MAYOR requesting authorization to appropriate and expend three hundred and fifteen thousand (\$315,000) from the Stormwater Management Fund Surplus to purchase a Vacuum Street Sweeper to be used by the Public Works Department for street cleaning operations.

Referred to Public Facilities and Finance Committees

#293-19

Appropriate \$150,280 for two trucks to be used by the Highway Department

HER HONOR THE MAYOR requesting authorization to appropriate and expend one hundred fifty thousand two hundred and eighty dollars (\$150,280) from bonded indebtedness for the purchase of two Ford F550 4x4 trucks for the Department of Public Works for street and snow operations.

Referred to Public Facilities and Finance Committees

#294-19

Appropriate \$739,059 for three 6-wheel trucks for the Highway Department

HER HONOR THE MAYOR is requesting authorization to appropriate and expend seven hundred thirty-nine thousand and fifty-nine dollars (\$739,059) from bonded indebtedness for the purchase of three 6-wheel trucks to be used by the Highway Department for street and snow operations.

#285-19

Mayor's re-appointment of Shawn Murphy to Constable

SHAWN MURPHY, of 11 Morrill Street, West Newton, re-appointed as a CONSTABLE of the City of Newton; said term of office to expire on September 15, 2022 (60 days: October 11, 2019).

Respectfully submitted,

Leonard J. Gentile, Chair

CITY OF NEWTON

IN CITY COUNCIL

June 3, 2019

ORDERED:

That, in accordance with the recommendation of the Public Facilities Committee and Finance Committee through their respective Chairs Deborah J. Crossley and Leonard J. Gentile, the sum of four hundred thousand dollars (\$400,000) to be appropriated from Free Cash, be and is hereby appropriated, granted, and expenditure authorized for the purpose of funding the completion of feasibility, schematic design, and site plan approval for the NewCAL project.

FROM: Free Cash
(01-3497).....\$400,000

TO: NewCAL Feasibility, Design, & Site Approval
(38E11520A-5795)\$400,000

Condition: The Public Buildings Department and the NewCAL Working Group must return to the Council upon completing their evaluation and recommendation of one or more sites, which must be done prior to the expenditure of \$150,000 of the \$400,000 appropriated, and that the Public Buildings Commissioner update the Council when the site list is narrowed to 3 to 5 sites.

Under Suspension Rules
Readings Waived and Approved
~~23~~ years ~~0~~ days 1 absent (Councilor Kelley)

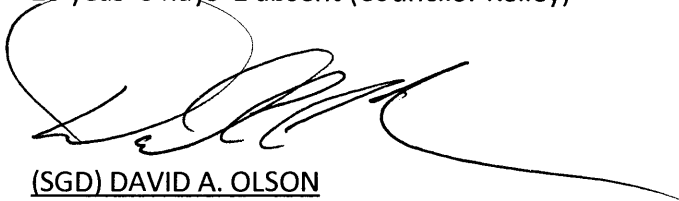

(SGD) DAVID A. OLSON
City Clerk



(SGD) RUTHANNE FULLER
Mayor

Date 6/7/19



RUTHANNE FULLER
MAYOR

City of Newton, Massachusetts
Office of the Mayor

#287-19

Telephone
(617) 796-1100

Telefax
(617) 796-1113

TDD
(617) 796-1089

E-mail
rfuller@newtonma.gov

August 5, 2019

Honorable City Council
Newton City Hall
1000 Commonwealth Avenue
Newton Centre, MA 02459

Councilors:

I write to docket for your consideration a request to approve the appointment of Rosemarie Woods as the City's Treasurer/Tax Collector. Rosemarie is currently the Assistant Treasurer/Collector, a position she has held since December 2018. Prior to that time, Rosemarie held the position of Assistant Collector since 2010.

Rosemarie has been responsible for the management of a staff of eight, preparation and disbursement of City vendor payments, payroll issuance and disbursement, management of ACH & wire transfers, and management of real estate files in preparation for demands and notices of delinquency, among other duties.

Rosemarie has the knowledge, experience and leadership qualities to lead this critical department. She has my complete confidence and that of Maureen Lemieux.

Thank you for your consideration of this matter.

Sincerely,

Ruthanne Fuller
Mayor

RECEIVED
Newton City Clerk
2019 AUG -5 PM 4:08
David A. Stewart, City
Newton, MA 02459

ROSEMARIE A. WOODS
87 Clocktower Dr
Waltham, Massachusetts 02452

PROFESSIONAL EXPERIENCE

City of Newton, MA Treasury Department

September 2009 – Present

Assistant Treasurer & Collector

January 2019 – Present

- Manages preparation and disbursement of City vendor payments for purchases and services including bank funding, file transmittal and cash book updates
- Manages City payroll issuance and disbursement and related deduction payments including payment of state and federal tax withholding and health and life insurance
- Communicates with various banks daily to verify balances, generate ACH & wire transfers, manage stop payments and other bank transactions
- Directs billing and collection of City revenue including real estate, personal property, motor vehicle excise tax, water and sewer bills and betterments
- Manages City wide accounts receivable and turnover business and reconciles to the City's general ledger quarterly
- Maintains real estate files in preparation for demands and notices of delinquency, prepares notices of advertisement for unclaimed property and works on tax title accounts
- Prepares updates to City's preliminary official statement on bond issuances
- Provides assistance to cross-functional departments pertaining to delinquent, unpaid or bankrupts accounts and collection actions by the Treasurer/Collector

Assistant Collector

August 2010 – December 2018

- Manage eight-person staff charged with performing full range of administrative and operational duties of the City of Newton's Treasury and Collection Department.
- Manage the billing, collection, and reporting of all committed real estate, personal property, motor vehicle excise revenue as well as utility billing, parking violations and other municipal revenues under the direction of the City's Treasurer/Collector and Chief Financial Officer.
- Responsible for vendor and payroll cash disbursements for purchases and services, tracking unclaimed property and adherence to Tailings policy, stop payments and manual reissuances, and reconciling deferred tax accounts.
- Supervise monthly bank reconciliations, initiates bank wires and ACH via checkless warrants, issues manual checks
- Work closely with other municipal departments on City initiatives such as performance metrics, IT related projects and Request for Proposals related to banking services and parking ticket collections.

Office Manager

September 2009 - August 2010

- Responsible for full range of administrative supervision and direction of eight-person staff charged with performing services of the City of Newton's Treasury and Collection Department.
- Provide direct assistance to taxpayers and financial institutions by researching and resolving complex account issues on all Treasury related business.
- Document existing policies and procedures and implemented new processes to ensure consistency and effectiveness within office and adherence to Massachusetts General Law and city ordinances.

Massachusetts Institute of Technology, Cambridge, MA

September 2006 - Sept 2009

Senior Financial Assistant

- Responsible for entire Technology Licensing Office (TLO) Accounts Receivable portfolio including payment processing, refunds, bad debt write offs, cash collection and account reconciliations.
- Manage monthly invoice generation for patent expenses, running royalties and maintenance fees
- Responsible for review of licensee's royalty reports to ensure compliance with license agreement
- Primary point of contact for licensees and MIT internal departments to resolve complex accounts receivable issues
- Manage month end close and related reporting.

GENUITY (Formerly GTE Internetworking), Cambridge, MA

September 1995-Nov 2001

Project Manager

Feb 2000 - Nov 2001

- Work with product managers within the Security Service line in support of new and ongoing product development
- Coordinate with cross-functional groups from Security Engineering, QA, Operations and other groups in support of new product development and launches
- Establish and lead core team meetings to support product launches
- Create and manage project plans and project schedules across all functions
- Track all deliverables for the product releases and develop and execute service plans
- Coordinate Alpha and Beta test programs
- Work with various groups to ensure that systems and support materials are in place at the time of product launch, including legal, documentation and operational requirements

Credit Supervisor/Credit Analyst

September 1995 -February 2000

- Supervise daily operations of the Credit and Accounts Receivable departments
- Responsible for the credit analysis on new sales opportunities for all lines of business. This includes initial review of credit bureau reports from D&B and Experian
- Perform in-depth credit reviews on large dollar opportunities with start up businesses and marginal accounts. This includes financial statement analysis, trade and bank references, business plan review and personal credit review on principals.
- Work with sales team, product managers and finance to determine capital expenditure, development costs and financial exposure as related to specific deals. Draft credit requirements including deposit amounts & specific payment terms such as personal guarantees and Letter of Credit.
- Work with the customer and sales executive to obtain deposits, prepayments and arrange payment term
- Correspond with legal contract dept to ensure any necessary credit requirement language is included in quote/contract signed by the customer.
- Identify high-risk customers to cross-functional groups
- Manage customer refunds, bad debt write-off and recovery process in Oracle receivables
- Manage accounts receivable activity for America Online and ATT
- Manage cash applications for \$18 million monthly in Business Services revenue

Education:

B.S. University of Massachusetts, Amherst, Massachusetts

Computer Software Skills:

Munis Financials, Pentamation & FinancePlus, Quickbooks, Oracle Financial, SAP, ACT CRM Software, Microsoft Office Suite including Outlook, Microsoft Excel, Word, & MS Project

RECEIVED
Newton City Clerk

CITY OF NEWTON

2019 MAY -1 PM 4: 52 DOCKET REQUEST FORM

DEADLINE NOTICE: Council Rules require items to be docketed with the Clerk of the Council NO LATER THAN 7:45 P.M. ON THE MONDAY PRIOR TO A FULL COUNCIL MEETING.

To: Clerk of the City Council

Date: May 1, 2019

From (Docketer): Councilor Laredo

Address: _____

Phone: _____

E-mail: _____

Additional sponsors: Councilor Grossman

1. Please docket the following item (it will be edited for length if necessary):

PRESIDENT LAREDO requesting consideration of the recommendations of the special Blue Ribbon Commission regarding compoensation for the Mayor, City Council, and School Committee.

2. The purpose and intended outcome of this item is:

- Fact-finding & discussion
- Appropriation, transfer,
- Expenditure, or bond authorization
- Special permit, site plan approval,
- Zone change (public hearing required)
- Ordinance change
- Resolution
- License or renewal
- Appointment confirmation
- Other: _____

3. I recommend that this item be assigned to the following committees:

- Programs & Services
- Zoning & Planning
- Public Facilities
- Finance
- Public Safety
- Land Use
- Real Property
- Special Committee
- No Opinion

4. This item should be taken up in committee:

Immediately (Emergency only, please). Please state nature of emergency:

- As soon as possible, preferably within a month
- In due course, at discretion of Committee Chair
- When certain materials are made available, as noted in 7 & 8 on reverse
- Following public hearing

PLEASE FILL OUT BOTH SIDES

5. I estimate that consideration of this item will require approximately:

#208-19

- One half hour or less
- More than one hour
- More than one meeting
- Up to one hour
- An entire meeting
- Extended deliberation by subcommittee

6. The following people should be notified and asked to attend deliberations on this item. (Please check those with whom you have already discussed the issue, especially relevant Department Heads):

City personnel

Citizens (include telephone numbers/email please)

- _____
- _____
- _____
- _____
- _____

- _____
- _____
- _____
- _____
- _____

7. The following background materials and/or drafts should be obtained or prepared by the Clerk's office prior to scheduling this item for discussion:

8. I have or intend to provide additional materials and/or undertake the following research independently prior to scheduling the item for discussion. *

(*Note to docketer: Please provide any additional materials beyond the foregoing to the Clerk's office by 2 p.m. on Friday before the upcoming Committee meeting when the item is scheduled to be discussed so that Councilors have a chance to review all relevant materials before a scheduled discussion.)

Please check the following:

- 9. I would like to discuss this item with the Chairman before any decision is made on how and when to proceed.
- 10. I would like the Clerk's office to contact me to confirm that this item has been docketed. My daytime phone number is:
- 11. I would like the Clerk's office to notify me when the Chairman has scheduled the item for discussion.

Thank you.

Laredo Laredo
Signature of person docketing the item

[Please retain a copy for your own records]



July 24, 2019

Dear President Laredo and City Councilors,

Board of Directors

President

Marcia Johnson

Vice Presidents

Ellen Grody

Clerk

Theresa Fitzpatrick

Treasurer

Andrea Kozinetz

Directors

- Jen Abbott
- Bonnie Carter
- Alice Donisi-Feehan
- Frieda Dweck
- Susan Flicop
- Lois Levin
- Karen Manning
- Lisa Mirabile
- Linda Morrison
- Sharyn Roberts

On June 19, 2019, two members of the League of Women Voters of Newton (LWVN) observed a meeting held by the City Council's Programs and Services Committee regarding the recommendation of the Blue Ribbon Commission on Salaries. Our comments below are based on the work of the committee so far to review the recommendations of the Blue Ribbon Commission.

The League of Women Voters of Newton (LWVN) holds good governance as a core value. Our observations frequently separate out decisions on policy from the process by which the decisions are made. To date, the LWVN has not taken a position on whether to support or oppose an increase in compensation for our elected officials but does have comments on the process so far.

When we talk about process, we mean how our city government goes about making decisions. We appreciate that the City Council created the Blue Ribbon Commission on Salaries comprised of a variety of residents, none of whom currently serve as an elected official. This diverse group gave its recommendations to the City Council at the end of May, and since then the Programs and Services Committee has discussed it for at most 90 minutes, without arriving at or voting on a solid recommendation.

What seemed most important to the committee during its discussion was the time frame—how to accomplish a vote of the full City Council by the end of September in time to enact a pay raise for the incoming City Council in January. This was extremely disappointing, in part because it seemed as if there was already a general agreement about a raise, and the focus had turned to how much and how to hold a vote in time for the raise to start in January.

The Commission discussed at length their concern about equity among City Council and School Committee members as well as the impact of cost increases on the city, and neither concern has been further explored. The recommendation to restructure total compensation for elected officials was not enthusiastically received, and committee members noted that there would need to be a discussion with the Mayor about this proposal. Salary increase specifics were not discussed at great length either, though numbers went as high as \$19,000 as a base salary for City Council members, not including health benefits. Note that if the councilors' current base salary is nearly doubled, some would receive total annual compensation of almost \$40,000.

The Programs and Services Committee then agreed to start a public comment period in July and to leave it open until early September. We appreciate having so much time for the public to comment, but are unclear of the hearing's purpose and how this opportunity is being conveyed to the public. We are being asked to comment on the Blue Ribbon Commission recommendation, not on a proposal coming from this committee. There did not seem to be an overwhelming agreement with the proposal of the Blue Ribbon Commission, so we are unclear how much of a raise will be presented to the full City Council, the structure of the compensation, and the source of the funding. In short, what is the committee recommendation to be put forward to the full City Council? Will there be another public hearing and some public outreach about this issue once you have decided?

We hope that the committee focuses on more than a raise in base salary. The concern shown by the Blue Ribbon Commission on Salaries about equitable total compensation for all City Councilors and for all School Committee members deserves careful thought and their recommendations should be seriously considered and explored. Additionally the increased cost to the City and taxpayers also deserves time and thought. However, it appears that the rush to vote in time for the City Council to see a pay raise in January outweighs the need for transparency and deliberation.

We note several facts that might not be well-known by Newton residents that are also worthy of inclusion in any discussion on this topic:

- Elected officials are treated as full-time employees of Newton, and so are eligible for the same benefits as full-time teachers, policemen, firemen and other city employees, regardless of how many hours the elected officials work. We note that the positions of elected City Councilor and School Committee member are intended to be part-time. Only the Mayor position is officially full-time.
- The base salary for City Council and School Committee members hasn't changed in two decades. Those who do not take health benefits are compensated approximately \$10,000 and \$5,000 respectively.
- Health benefits can be worth over \$20,000 if an official participates in a family health plan. Currently, about half of all City Councilors and School Committee members join the health plan, meaning that they are compensated up to \$30,000 and \$25,000 respectively.
- The Blue Ribbon Commission on Salaries recommended a new structure of compensation for City Councilors and School Committee members as a way to begin to address this inequity among elected officials who do and do not take health insurance. We note that the Commission had a number of human resource professionals and attorneys as members who pushed back on the City Law Office's concern that this new structure would need to apply to all city employees.
- The Blue Ribbon Commission on Salaries was not charged with evaluating the funding source for any such increase, and so any additional cost to taxpayers for an increase in salaries still needs to be discussed and funds found.

In light of this rather non-transparent, rushed process, we are sending our letter to Village14.com, the Newton TAB, the Newton Patch, Newton News at NewTV and to all LWVN members in the hopes of sparking more discussion in the community.

Sincerely,



Marcia Johnson
President, League of Women Voters of Newton

Voting, Preliminary & Final Recommendations⁷

The Commission took straw votes on recommendations at its April 30, 2019 and May 14, 2019 meeting.

The Commission voted 8-2 to increase the Mayor’s salary. Four dollar amounts were discussed. First, the figure of \$135,000 was proposed as an adjustment that would be less than the peer group average for mayoral salaries. By a vote of 10-1 the Commission voted to increase the Mayor’s salary to at least \$135,000. Next, the figure of \$140,000 (i.e., the approximate average compensation in the peer group) was voted upon. Adjusting to at least that amount passed 10-1. Last, the figure of \$150,000 was proposed as a “split” between the \$140,000 peer group average and the \$160,000 figure resulting from a CPI-U adjustment to the salary. An increase to that level failed to pass with a 5-6 vote. Since an increase to \$160,000 did not have the support to pass, the final recommendation was to increase the Mayor’s salary to \$140,000 with no change to benefits.

The Commission next considered its recommendation for the City Council. **Chart 5** summarizes the alternatives that were considered.

CHART 5

OPTION #	Total Compensation	Salary	Equity Payment	Budget Impact
----------	-----------------------	--------	----------------	---------------

⁷ Final voting along with dissents can be found in Appendix I.

<p>1. No Change – Maintain Current Stipend And Continue Offer Of Health Benefits</p>	<p>\$9,750</p> <p><i>PLUS</i></p> <p>Cost/value of insurance benefits if elected</p>	<p>\$9,750</p> <p>(No change)</p>	<p>N/A</p>	<p>Unchanged salary model.</p> <p>Expense to the City varies to the extent there is a change (up or down) in the number of Councilors electing coverages year over year</p>
<p>2. Base salary, benefits OR equity pay when insurance not elected</p>	<p>\$9,750</p> <p><i>PLUS</i></p> <p>(1) Cost/value of insurance benefits elected</p> <p><i>OR</i></p> <p>(2) Equity payment for those who do not elect health insurance</p>	<p>\$9,750</p> <p>(No change)</p>	<p>Payment in an amount TBD paid to those Councilors who elect no insurance coverage (Opt-out)</p>	<p>Unchanged base salary model.</p> <p>Expense to the City varies based on:</p> <p>(1) The number and amount of equity payments made, and</p> <p>(2) The cost of insurance coverages elected by Councilors, which will vary to the extent there is a change (up or down) in the number of Councilors electing coverages year over year</p>
<p>3. Increase to base salary for all and continued health benefits option – no equity payment</p>	<p>Increase above \$9,750 with amount TBD</p> <p><i>PLUS</i></p> <p>Cost/value of insurance benefits if elected</p>	<p>Increase above \$9,750, with amount TBD</p>	<p>N/A</p>	<p>Salary model is changed</p> <p>Expense to the City varies based on:</p> <p>(1) The increased salary amount for each councilor</p> <p>(2) The cost of insurance coverages elected by Councilors, which will vary to the extent there is a change (up or down) in the number of Councilors electing coverages year over year</p>

<p>4. Increase to base salary for all and continued benefits option OR equity pay</p>	<p>Increase above \$9,750 with amount TBD</p> <p><i>PLUS</i></p> <p>Cost/value of insurance benefits elected</p> <p><i>OR</i></p> <p>(1) Equity payment</p>	<p>Increase above \$9,750, with amount TBD</p>	<p>Equity payment in an amount TBD paid to those Councilors who elect no insurance coverage (irrespective of her/his prior year’s coverage status).</p> <p>The equity amount may be:</p> <p>(1) a set amount, or (2) a percentage of the savings attributable to the saved cost of the “no coverage” election.</p>	<p>Salary model is changed</p> <p>Expense to the City varies based on:</p> <p>(1) The increased salary amount for each councilor</p> <p>(2) The cost of insurance coverages elected by Councilors, which will vary to the extent there is a change (up or down) in the number of Councilors electing coverages year over year PLUS the amount and number of equity payments made</p>

While there was significant debate about adopting the total compensation approach (i.e, Option #2), the final vote supported Option #4 which would provide all Councilors with an increase in stipend to \$14,000, continued health benefits and, for those who do not participate in the city’s health plan, a \$5,000 increment to salary (referred to as the “equity payment” in Chart 5). The \$5,000 so-called equity pay would be provided to those Councilors who either discontinue electing health benefits for a plan year, as well as those Councilors who have not elected health benefits without regard to whether they previously elected health benefits. This approach aims to create greater parity in compensation while recognizing the significant amount of time that has passed since the last compensation increase.⁸

⁸ One Councilor’s survey response indicated that he/she decided each year on whether to elect health benefits depending upon whether it was economically better for him/her to elect the City’s benefits or those offered by his/her private employer. With City’s cost for the health benefits approximating \$20,000 for each Councilor and School Committee member who elects Newton’s benefits, the Commission’s recommendation of providing an incremental salary amount for those who do not elect to use City health benefits is intended to provide a positive incentive to tip the scales in that choice in favor of individuals electing to take the health insurance benefits that are available to them from a source other than the City.

The Commission chose to utilize the same compensation model for the School Committee, although in their case the stipend would increase to \$7,500 and the recommended amount of the incremental salary for the School Committee members who do not elect health benefits would be \$2,500.

Recommendations - Summary Chart

	Salary	Benefits	Supplemental
Mayor	\$140,000	Yes	Use of car
City Council	\$14,000	Yes	Incremental pay of \$5,000 for those who are not on any of the city’s health plans
School Committee	\$7,500	Yes	Incremental pay of \$2,500 for those who are not on any of the city’s health plans

The Commission was also asked to make recommendations about future adjustments to elected officials’ compensation. Rather than making a recommendation on a formulaic approach to future adjustments to elected officials’ compensation, the Commission recommends that the City Council vote to convene a Blue Ribbon Commission in five years (i.e., in 2024) and every four years thereafter to ensure a regular review of total compensation to avoid the review occurring during an election year. This recommendation is not intended to suggest that adjustments to compensation should or should not be made at those intervals but rather to establish a system by which compensation will be evaluated at regular intervals. It will be up to future Blue Ribbon Commissions to determine whether any adjustment to the compensation of some or all officials is then warranted and the amount thereof.

Respectfully Submitted,

Blue Ribbon Commission



RUTHANNE FULLER
MAYOR

City of Newton, Massachusetts

Office of the Mayor

#291-19

Telephone
(617) 796-1100

Telefax
(617) 796-1113

TDD
(617) 796-1089

E-mail
rfuller@newtonma.gov

August 5, 2019

Honorable City Council
Newton City Hall
1000 Commonwealth Avenue
Newton Centre, MA 02459

Councilors:

I respectfully submit a docket item to your Honorable Council requesting authorization to appropriate and expend \$70,000 from Acct # 0110498-579000 FY2020 Budget Reserve to install surveillance cameras at the Rumford Ave Recycling Center, as well as the Eliot Street and Crafts Street buildings.

Thank you for your consideration of this matter.

Sincerely,

Ruthanne Fuller
Mayor

RECORDED
2019 AUG -5 PM 4:13
Newton City Clerk
David A. Green, City
Recorder, MA 02459

City of Newton



DEPARTMENT OF PUBLIC WORKS

OFFICE OF THE COMMISSIONER

1000 Commonwealth Avenue
Newton Centre, MA 02459-1449

Ruthanne Fuller
Mayor

To: Mayor Ruthanne Fuller
Maureen Lemieux, CFO
Jonathan Yeo, COO

From: Jim McGonagle, Commissioner of Public Works

Subject: Cameras

Date: 7/29/19

I write to request that the Honorable Council docket for consideration a request to authorize the appropriation of \$70,000 to install surveillance cameras at the Rumford Ave Recycling Center, as well as the Eliot St. and Craft St. buildings.

Thank you for your consideration

Jim McGonagle
Commissioner of Public Works

Jim McGonagle
Commissioner

Telephone: (617) 796-1009 • Fax: (617) 796-1050 • jmcgonagle@newtonma.gov

Camera Project Estimate at Crafts Street, Elliot Street & Rumford Ave

7/26/2019

1 Security/Fiber Network:		
Cameras	\$	1,679 (Crafts Street)
Cameras	\$	43,877 (Elliot Street)
Cameras	\$	14,606 (Rumford Ave)
Temp Tie In for cameras/fiber	\$	<u>2,650 (Rumford Ave)</u>
2 Sub Total Project Estimate	\$	62,812
3 Project Contingency	\$	<u>6,281</u>
4 Project Total	\$	69,093



98 Galen St
Watertown, MA 02472
Tel: 617-864-3676

8/24/2018

ATTN : Shane Mark
REF: Camera System Craft Street Yard Exterior

City Of Newton
1000 Commonwealth Ave
Newton MA 02459

Dear Shane,

Part A.1 This proposal is for (6) camera licenses. The video management system (Avigilon Video Server) is proposed separately to the City per Joe Mulvey. Pricing includes setting up (1) client within the DPW. **Part A.2** is to deploy (6) Avigilon cameras at locations determined in the field walk thru. There will be (6) outdoor cameras. (2) will attach to the DPW Stable building. (1) at the fuel pumps and (1) 3 head multisensor east corner of building. The remaining (4) will be 3 head multisensor type and will be distributed as follows: (2) in the rear of the building, one capturing the yard in front of the two storage buildings, one catching the paint bay/parking lot (1) outside garage entrance across from fueling area and (1) outside the main entrance door from Craft Street catching the front door, both parking lots and entering the garage area.

Part A.1 Video System Licensing and Client Software

QTY	Description		Amount
1	4C-ACC6-ENT ACC 6 Enterprise license for up to 4 camera channels	@ \$ 693.00	\$ 693.00
2	1C-ACC6-ENT ACC 6 Enterprise license for up to 1 camera channel	@ \$ 201.00	\$ 402.00
*Enterprise comes with unlimited viewing licenses			
**pricing assumes using existing computers/monitors for viewing clients			
Total Equipment			\$ 1,095.00
10% Mark UP			\$ 109.50
Total -Installation, Testing			\$ 500.00
Total			\$ 1,704.50

Part A.2 IP Camera Install

QTY	Description		Amount
5	9W-H3-3MH-DP1-B 3 Image Sensor Pendant HD Multisensor Dome Camera	@ \$ 1,125.00	\$ 5,625.00
1	5.0L-H4A-BO2-IR 5.0MP, H4 HD Bullet, 9-22mm (fuel pump)	@ \$ 717.00	\$ 717.00
5	H4-MT-CRNR1 Corner Mounting Bracket	@ \$ 54.00	\$ 270.00
1	Bucket Truck Rental	@ \$ 600.00	\$ 600.00
1	Cat 6 Cable 1000'	@ \$ 210.00	\$ 210.00
1	Misc, Jacks, Patchcords, RJ-45 Connectors, Firestop, Labels	@ \$ 100.00	\$ 100.00
Total Equipment			\$ 7,522.00
10% Mark UP			\$ 752.20
Total -Installation, Testing			\$ 6,200.00
Total			\$ 14,474.20

Part A.1	Video System Licensing and Client Software	\$ 1,704.50
Part A.2	IP Camera Install	\$ 14,474.20
Total Cost		\$ 16,178.70

Clarifications & Exclusions

All Power Requirement by Electrical Contractor

All work to be performed during normal working hours Monday - Friday 7am to 3:30 pm.

All IP Cameras require POE from network switches. All IP Cameras are assumed to be on City of Newton network unless called out for within this proposal.

We thank you for this opportunity to be of service, if you have any questions please contact the undersigned.

Sincerely,



Adam Sherlock
Project Manager
Viscom Systems Inc.



98 Galen St
Watertown, MA 02472
Tel: 617-864-3676

9/6/2018

ATTN : Shane Mark
REF:Camera System 60 Elliot Street Yard Exterior

City Of Newton
1000 Commonwealth Ave
Newton MA 02459

Dear Shane,

Part A.1 This proposal is for (16) camera licenses. The video management system (Avigilon Video Server) is proposed separately to the City per Joe Mulvey. Pricing includes setting up (1) client within the DPW. **Part A.2** is to deploy (16) Avigilon cameras at locations determined in the field walk thru. There will be (16) outdoor cameras. (1) will attach to the back building for a parking lot (Ted Jerdee's building) The remaining (15) will be distributed the following: (4) on the exterior of 60 Elliot for coverage of all parking lots and (1) on the rear to cover the entrance to the DPW yard. (5) will be attached to the garage building to cover parts of the DPW yard, (4) will be attached to the Salt barn and will be connected to the network via a Fluid Mesh wireless connection. A 12' x 18 x 6" can will be mounted to the Salt barn and will require Power from the DPW to power a network switch and the Fluid Mesh. There will also be (1) camera mounted to the back of the Firestation to cover the very back of the DPW yard.

Part A.1 Video System Licensing and Client Software

QTY	Description		Amount
1	16C-ACC6-ENT ACC 6 Enterprise license for up to 16 camera channels	@	\$ 2,697.00
	*Enterprise comes with unlimited viewing licenses		Total Equipment \$ 2,697.00
	**pricing assumes using existing computers/monitors for viewing clients		10% Mark UP \$ 269.70
			Total -Installation, Testing \$ 960.00
			Total \$ 3,926.70

Part A.2 IP Camera Install

QTY	Description			Amount
1	8L-H4PRO-B - 4K (8 MP) H.264 HD Pro with LightCatcher Technology	@	\$ 1,251.00	\$ 1,251.00
2	3.0C-H4A-BO1-IR 3.0MP WDR, H4 HD Bullet, 3-9mm	@	\$ 621.00	\$ 1,242.00
3	5.0L-H4A-BO2-IR 5.0MP, H4 HD Bullet, 9-22mm	@	\$ 717.00	\$ 2,151.00
10	8.0-H4A-BO1-IR 4K UHD 8.0MP, H4 HD Bullet, 4.3-8mm	@	\$ 900.00	\$ 9,000.00
1	LEF2414CA - Canon, 24mm, f/1.4, Auto-Iris	@	\$ 2,124.00	\$ 2,124.00
1	ES-HD-HWS-LG - Large Format Enclosure, Heater, Wall Bracket and Sunshield, IP66	@	\$ 249.00	\$ 249.00
1	Fluid Mesh 3200-60 Wireless Base Station	@	\$ 1,731.00	\$ 1,731.00
1	Fluid Mesh 1200 Volo Wireless Antenna	@	\$ 548.00	\$ 548.00
1	Fluid Mesh 1200 Volo Hardware	@	\$ 420.00	\$ 420.00
1	Outdoor Rated 18"x12" Equipment Cabinet (salt barn	@	\$ 260.00	\$ 260.00
1	8 Port POE Switch (salt barn)	@	\$ 179.00	\$ 179.00
1	Misc 1/2" PVC Conduit, Unistrut Etc (4) cameras/(1) wireless	@	\$ 430.00	\$ 430.00
2	Bucket Truck Rental (two weeks)	@	\$ 900.00	\$ 1,800.00
2	Cat 6 Cable 1000'	@	\$ 210.00	\$ 420.00
1	Misc, Jacks, Patchcords, RJ-45 Connectors, Firestop, Labels	@	\$ 150.00	\$ 150.00
Total Equipment				\$ 21,955.00
10% Mark UP				\$ 2,195.50
Total -Installation, Testing				\$ 15,800.00
Total				\$ 39,950.50

Part A.1	Video System Licensing and Client Software	\$ 3,926.70
Part A.2	IP Camera Install	\$ 39,950.50
Total Cost		\$ 43,877.20

Clarifications & Exclusions

All Power Requirement by Electrical Contractor

All work to be performed during normal working hours Monday - Friday 7am to 3:30 pm.

All IP Cameras require POE from network switches. All IP Cameras are assumed to be on City of Newton network unless called out for within this proposal. (Salt Barn POE switch)

We thank you for this opportunity to be of service, if you have any questions please contact the undersigned.

Sincerely,

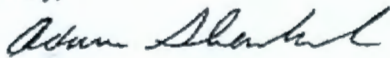

Adam Sherlock
Project Manager
Viscom Systems Inc.



98 Galen St
Watertown, MA 02472
Tel: 617-864-3676

10/3/2018

ATTN : Josh Morse
REF:Camera System DPW Recycling Center

City Of Newton
1000 Commonwealth Ave
Newton MA 02459

Dear Josh,

Part A.1 This proposal is for (5) camera licenses. The video management system (Avigilon Video Server) is proposed separately to the City of Newton per Joe Mulvey. Pricing includes setting up (1) client within the Recycling Center, applying licenses and 2 hours of training for local party in charge. **Part A.2** is to deploy (5) Avigilon cameras at locations determined in the field walk thru. There will be (5) outdoor cameras. (2) will attach to the main building. The other 3 cameras will be run to 2 separate telephone poles on the property. (1) cat 5e outdoor cable will be needed for each of these cameras and will need to attach to 3 poles abutting the property and 3 poles on the property.

Part A.1 Video System Licensing and Client Software

QTY	Description		Amount
1	1C-ACC6-ENT ACC 6 Enterprise license for 1 camera channels	@ \$ 201.00	\$ 201.00
1	4C-ACC6-ENT ACC 6 Enterprise license for up to 4 camera channels	@ \$ 693.00	\$ 693.00
	*Enterprise comes with unlimited viewing licenses		
	**pricing assumes using existing computers/monitors for viewing clients		
	Total Equipment		\$ 894.00
	10% Mark UP		\$ 89.40
	Total -Installation, Testing		\$ 960.00
	Total		\$ 1,943.40

Part A.2 IP Camera Install

QTY	Description		Amount
3	8.0-H4A-BO1-IR-B	@ \$ 900.00	\$ 2,700.00
2	5.0L-H4A-BO1-IR-B	@ \$ 621.00	\$ 1,242.00
5	H4-BO-JBOX1	@ \$ 54.00	\$ 270.00
3	H4-MT-POLE1	@ \$ 54.00	\$ 162.00
1	8 Port POE Switch	@ \$ 179.00	\$ 179.00
1	Misc 1/2" PVC Conduit, Unistrut Etc (4) cameras/(1) wireless	@ \$ 430.00	\$ 430.00
1	Bucket Truck Rental	@ \$ 450.00	\$ 450.00
1	Cat 6 Cable 1000' (outdoor)	@ \$ 322.00	\$ 322.00
1	Misc, Jacks, Patchcords, RJ-45 Connectors,Kellem, pole attachments, Labels	@ \$ 120.00	\$ 120.00
	Total Equipment		\$ 5,875.00
	10% Mark UP		\$ 587.50
	Total -Installation, Testing		\$ 6,200.00
	Total		\$ 12,662.50

Part A.1	Video System Licensing and Client Software	\$ 1,943.40
Part A.2	IP Camera Install	\$ 12,662.50
	Total Cost	\$ 14,605.90

Clarifications & Exclusions

All Power Requirement by City of Newton (POE Network Switch)

All work to be performed during normal working hours Monday - Friday 7am to 3:30 pm.

All IP Cameras require POE from network switches, we are providing one until City of Newton POE switch and network installed.

Viscom Assumes Cat5e cabling will be allowed on telephone poles as specified

We thank you for this opportunity to be of service, if you have any questions please contact the undersigned.

Sincerely,



Adam Sherlock
Project Manager
Viscom Systems Inc.



RUTHANNE FULLER
MAYOR

City of Newton, Massachusetts
Office of the Mayor

#292-19

Telephone
(617) 796-1100

Telefax
(617) 796-1113

TDD
(617) 796-1089

E-mail
rfuller@newtonma.gov

August 5, 2019

Honorable City Council
Newton City Hall
1000 Commonwealth Avenue
Newton Centre, MA 02459

Councilors:

I respectfully submit a docket item to your Honorable Council requesting authorization to appropriate and expend \$175,000 and authorize a general obligation borrowing of an equal amount for the purchase and fit up of a modular trailer to be used as an office space for Public Works employees, as well as to provide restroom and eye wash station facilities at the Rumford Ave Recycling Center.

Further, I request that your Honorable Council authorize any premium received upon the sale of the bonds or notes, less the cost of preparing, issuing and marketing them, and any accrued interest received upon the delivery of the bonds or notes be applied to the costs of the project being financed by the bonds or notes and to reduce the amount authorized to be borrowed for the project by a like amount.

Thank you for your consideration of this matter.

Sincerely,

Ruthanne Fuller
Mayor

David A. Gifford, Clerk
Newton, MA 02459

2019 AUG -5 PM 4:13

RECEIVED
MAYOR'S OFFICE

City of Newton



DEPARTMENT OF PUBLIC WORKS

OFFICE OF THE COMMISSIONER

1000 Commonwealth Avenue
Newton Centre, MA 02459-1449

Ruthanne Fuller

Mayor

To: Mayor Ruthanne Fuller
Maureen Lemieux, CFO
Jonathan Yeo, COO

From: Jim McGonagle, Commissioner of Public Works

Subject: Rumford Ave Modular Building

Date: 7/29/19

I write to request that the Honorable Council docket for consideration a request to authorize the appropriation of \$175,000 to purchase and outfit a modular trailer to be used as an office space for Public Works employees as well as provide restroom and eye wash station facilities at the Rumford Ave Recycling Center. The requested funding will include purchase, delivery, installation, and complete outfitting of the building that includes fiber, water, and electric service.

Thank you for your consideration

Jim McGonagle
Commissioner of Public Works

Jim McGonagle
Commissioner

Telephone: (617) 796-1009 • Fax: (617) 796-1050 • jmcgonagle@newtonma.gov

Rumford Ave Office Trailer Project Costs

1 New Building:

Modular Building	\$	50,134
Fiber	\$	18,750
Electric Service/new pole/trenching	\$	35,000
Electrical	\$	14,250
Plumbing	\$	7,500
Site work	\$	5,000
Design	\$	<u>30,000</u> *

2 Sub Total Project Estimate \$ 160,634

3 Project Contingency \$ 16,063

4 Project Total \$ 176,697

*Design of Electric service (Eversource) & modular bid documents

TRIUMPH MODULAR
 194 AYER ROAD
 LITTLETON, MA 01460
 (800)257-2536



#292-19

PAY ONLINE at triumphmodular.com
 Account #: 1832
 Email:
 Zip Code: 02459

BID/QUOTE

PRINT DATE: 07/29/19 Page 1

Customer:	Ticket#	Delivery Location:
City Of Newton 1000 Commonwealth Ave. Newton Centre MA 02459	Bid# 134127	Off Rumford Ave Newton MA 02459



Ordered by: Art Cabral	PO/Job # Dpw	Estimated Billing Cycle Start: 09/23/19	LT1
On-Site: Art Cabral	S/Spn: L Turner	Estimated Billing Cycle Stop: 10/23/19	LT1
Phone: (617) 594-2457	Terms: Net 30		

Qty	Item	Description	Rate	Total
SOLD ITEMS				
1	OT-1X	New 10 X 44 Office Trailer W/B		44375.00
1	OT-TRA	Trailer Delivery		414.00
1	OT-SET	Trailer Set Up, Block + Level		375.00
8	OT-TIE	Tie Downs - Asphalt		920.00
100	OT-SKI	Skirting - Vinyl		1900.00
2	ALUM S	Alum Stairs		2150.00

New From Factory
Lead Time Estimated 8-10 wks from executed contract

Please note that purchase orders provided by you are for accuracy of invoicing only, by accepting delivery of the property on this order you accept the terms and conditions attached hereto, with or without signature.

FOR SERVICE CALL 800-408-1688
 ACCOUNTING CALL 978-431-1000

Lease Subtotal	0.00
Sales Subtotal	4,970.00
Trans / Del Subtotal	45,164.00
Sales Tax	0.00
Total	50,134.00

We thank you for your business

I HAVE READ AND AGREE TO THE TERMS OF THIS CONTRACT.

LESSEE: X _____

10 x 44 Office Trailer w/ Bath

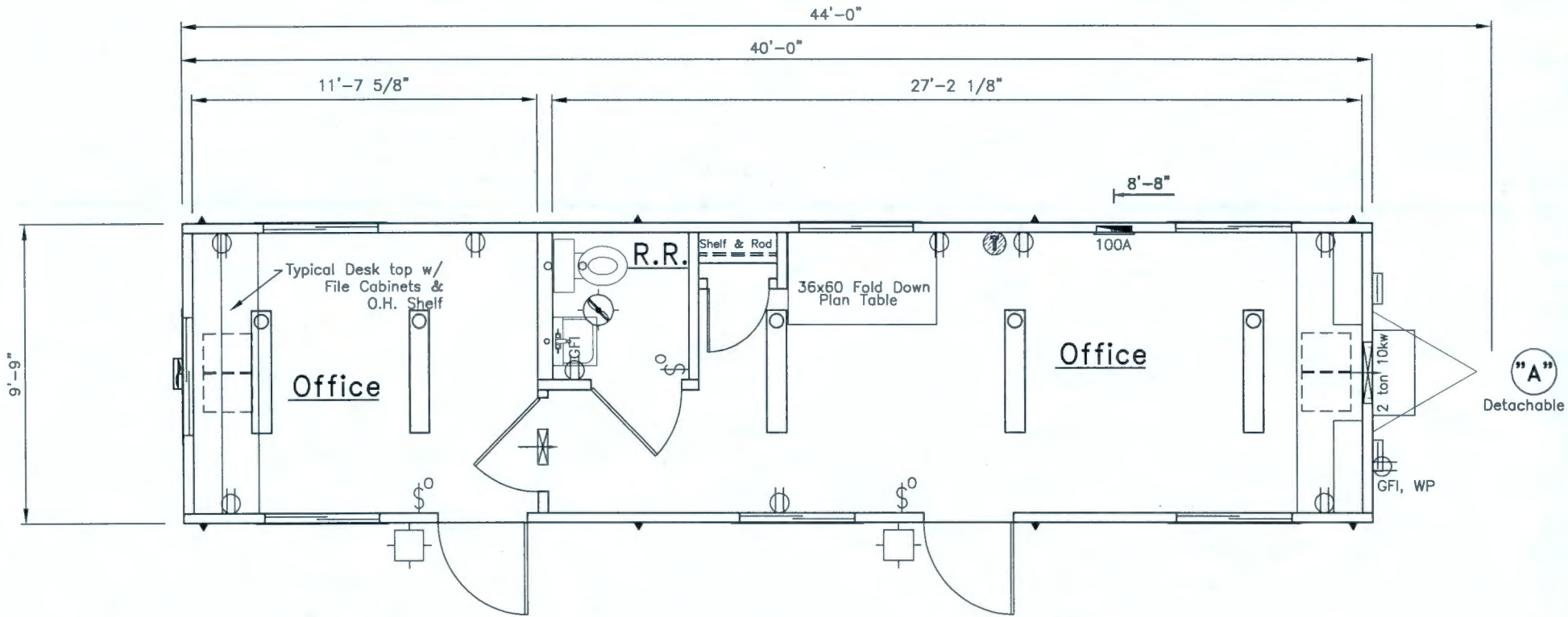

Restrooms optional on most models. Standard layouts - door, window, partition & bathroom layouts may vary slightly depending on manufacturer



City of Newton
Addition of 115 Rumford Avenue, Auburndale
Newton Fiber Optic Municipal Area Network - ITC 54

Prepared by:	Comm-Tract Corp. 235 Summer Road, Bldg. # 4 Boxborough, MA 01719	Contact:	Bryan Hopkins
		Telephone:	(781) 890-5070 x6952
		Email:	bhopkins@comm-tract.com
Date:	April 18, 2018		

Bid No.	115 Rumford Avenue
Customer Number	

Bill To:		Ship To:	
Company:	City of Newton 1000 Commonwealth Avenue Newton Centre, MA 02459	Company:	City of Newton 1000 Commonwealth Avenue Newton Centre, MA 02459
Address:		Address:	
Contact Name:	Joe Mulvey	Contact Name:	Joe Mulvey
Phone:	(617) 796-1188	Phone:	(617) 796-1188
Fax:		Fax:	
Email:	jmulvey@newtonma.gov	Email:	jmulvey@newtonma.gov

Description of Work

Fiber Optic Municipal Area Network
Addition of 115 Rumford Avenue

- We propose to furnish and install (1) 12 Count Corning SMF-28e single mode fiber optic cable from the City of Newton existing fiber backbone cable located in the vicinity of Webster Street and Cherry Street to 115 Rumford Avenue, Auburndale.
- We propose to furnish and install (1) Corning 1U rack or wall mount SC/PC termination panel and will terminate 12 fibers onto SC/PC connectors within the 115 Rumford Avenue MDF room.
- We propose to enter the existing backbone splice case located on Webster Sreet and splice diversely 4 fibers in each direction around the ring.
- The fiber route will be Cherry Street, to River Street to Rumford Avenue.
- The fiber cable will be placed in the municipal space on the joint owned utility poles.
- All fiber testing will be to industry standards.



City of Newton
Addition of 1Mt. Ida College, 777 Dedham Street - ITC 54
Newton Fiber Optic Municipal Area Network

Quantity	Bill of Materials Description
----------	----------------------------------

5,280 Feet	Corning SMF-28e Single Mode Fiber Optic Cable
1	Corning 1U Rack or Wall Mount Termination Panel
12	Corning SC/PC Connectors
1	Corning 12 Way Fan-out Kit
1	Corning 12 Way SC/PC Bulkhead Panel
12	Fusion Heat Shrinks
35	Galvanized 5/8" Pole Line Hardware
6	Snow Shoes for Aerial Slack Storage
	Other Miscellaneous Materials



City of Newton
 Addition of 1Mt. Ida College, 777 Dedham Street - ITC 54
 Newton Fiber Optic Municipal Area Network

Warranty Information - Technical and Compliance Notes:

The Comm-Tract provided manufacturers warranty and technical compliance with design and installation standards information is provided below as associated with this scope of work.

- Comm-Tract is an approved Extended Warranty Provider (EWP) for Corning Cable Systems.
- The 25 Year Corning EWP Warranty commencing on the date of an accepted installation by the Customer covers all Corning Cabling Systems products and covers the repair, and/or replacement of all installed components including, but not limited to fiber cable, fiber connectors, fiber patch panels, fiber jumpers and patch cords, and other materials as installed.
- The repair and/or replacement of any component in the certified and approved network solution as provided and installed by Comm-Tract under the EWP Warranty is provided at no cost to the Customer 25-year period of the EWP Warranty.

- Comm-Tract adheres to the following design and installation standards relative to the scope of work as provided.
 - BICSI Design and Installation Applicable Standards
 - Telecommunications Industry Association (TIA) Applicable Standards
 - Electronics Industry Association (EIA) Applicable Standards
 - ANSI/TIA/EIA – 568 Standards
 - ANSI/TIA/EIA – 569 Standards
 - TIA/EIA 604 Fiber Optic Standards
 - TIA-492 Fiber Optic Installation Standards
 - TSB-149 Fiber Optic Workmanship Standards
 - IEEE 802.3 Standards



City of Newton
Addition of 1Mt. Ida College, 777 Dedham Street - ITC 54
Newton Fiber Optic Municipal Area Network

Special Terms

Customer agrees to the following payment schedule:

30%	Payment upon receipt of materials.	\$ 5,625.00
65%	Payment upon actual project progress.	\$ 12,187.50
5%	Payment upon completion.	\$ 937.50

- The Project Price shall be subject to adjustment in the event of any mutually agreed upon written changes made to the Scope of Work. Any changes during the project to the Scope of Work will be mutually agreed to in writing with Customer prior to any changes, or additional charges being added or deleted to the project.
- Prices are valid for 30-days.
- The Project Price does not include licensing of pole or underground facilities.
- The Project Price does not include police details.
- The Project Price does not include permitting is applicable.
- The Project Price does not include any new underground construction.
- The Project Price does not include any applicable taxes as the project is tax exempt.
- The Project Price includes shipping charges.
- The Project Price assumes access to each location is free and clear.
- Comm-Tract will perform during normal business hours – Monday through Friday, 8:00 a.m. to 5:00 p.m., unless otherwise specified in the Description of Work.
- Customer hereby agrees to the terms and conditions set forth in the Scope of Work by signing below or issuing a Purchase order referencing this Scope of Work.
- This Scope of Work is governed by the terms and conditions of the Commonwealth of Massachusetts ITC 54 blanket contract.

Est. Completion Date:	TBD
Materials:	
Labor:	
Total	\$ 18,750.00

Customer Name:	
Authorized Signature:	
Name:	
Date:	



RUTHANNE FULLER
MAYOR

City of Newton, Massachusetts
Office of the Mayor

#289-19

Telephone
(617) 796-1100

Telefax
(617) 796-1113

TDD
(617) 796-1089

E-mail
rfuller@newtonma.gov

August 5, 2019

Honorable City Council
Newton City Hall
1000 Commonwealth Avenue
Newton Centre, MA 02459

Councilors:

I respectfully submit a docket item to your Honorable Council requesting authorization to appropriate and expend \$496,000 from the Sewer Fund Surplus – Available for Appropriation Account to purchase a Vactor combination cleaner truck to be used by the Public Works Department during sewer cleaning operations.

Thank you for your consideration of this matter.

Sincerely,

Ruthanne Fuller
Mayor

2019 AUG -5 PM 4: 12
J. A. Green, Clerk
City of Newton, MA 02459

City of Newton



DEPARTMENT OF PUBLIC WORKS

OFFICE OF THE COMMISSIONER

1000 Commonwealth Avenue
Newton Centre, MA 02459-1449

Ruthanne Fuller

Mayor

To: Mayor Ruthanne Fuller
Maureen Lemieux, CFO
Jonathan Yeo, COO

From: Jim McGonagle

Subject: Vactor Truck

Date: 8/5/19

I write to request that the Honorable Council docket for consideration a request to authorize the appropriation of \$496,000 for the purchase of a Vactor combination cleaner truck to be used by the Public Works Department during sewer cleaning operations.

Thank you for your consideration of this matter.

Sincerely,

Jim McGonagle
Commissioner of Public Works

Jim McGonagle
Commissioner

Telephone: (617) 796-1009 • Fax: (617) 796-1050 • jmcgonagle@newtonma.gov

MUNICIPAL AND CONTRACTORS' EQUIPMENT

200 Merrimac St
Woburn MA 01801

PROPOSAL

Tel. (781) 935 1919
Fax [781] 937 9809

Date

City of Newton
Department of Public Works
110 Crafts St
Newton, MA 02458
ATT: Travis Mosca Fleet Supervisor

August 5, 2019

C. N. Wood is pleased to offer the following budget proposal through the Greater Boston Police council contract.

1 New Vactor 2110I combination sewer cleaner mounted on a Mack single axle chassis per attached specifications.

TOTAL SELLING PRICE \$495,255.00

C. N. Wood Co, Inc. is looking forward to providing the City of Newton with the Vactor premium products and first class service. Please do not hesitate to contact me if you have any questions or need further information.

Best Regards,
Stephen M. Russell
Sales Representative

No warranties are made other than those extended by the manufacturer of the equipment, and in the event of alleged breach of warranty, expressed or implied, the liability of C. N. Wood Co., Inc., shall be limited to the liability of the manufacturer to it, and shall be subject to all limitations and conditions imposed by the manufacturer.

Seller shall not be liable for any default or delay in delivery, as a result of shipping delays, strikes, fires, lockouts, or inability to procure materials.





RUTHANNE FULLER
MAYOR

City of Newton, Massachusetts
Office of the Mayor

Telephone
(617) 796-1100

Telefax
(617) 796-1113

TDD
(617) 796-1089

E-mail
rfuller@newtonma.gov

August 5, 2019

Honorable City Council
Newton City Hall
1000 Commonwealth Avenue
Newton Centre, MA 02459

Councilors:

I respectfully submit a docket item to your Honorable Council requesting authorization to appropriate and expend \$315,000 from the Stormwater Management Fund Surplus – Available for Appropriation Account to purchase a Vacuum Street Sweeper to be used by the Public Works Department during street cleaning operations.

Thank you for your consideration of this matter.

Sincerely,

Ruthanne Fuller
Mayor

RECEIVED
Newton City Hall
2019 AUG -5 PM 4: 12
David A. ...
Newton, MA 02459

City of Newton



DEPARTMENT OF PUBLIC WORKS

OFFICE OF THE COMMISSIONER

1000 Commonwealth Avenue
Newton Centre, MA 02459-1449

Ruthanne Fuller

Mayor

To: Mayor Ruthanne Fuller
Maureen Lemieux, CFO
Jonathan Yeo, COO

From: Jim McGonagle

Subject: Sweeper

Date: 8/5/19

I write to request that the Honorable Council docket for consideration a request to authorize the appropriation of \$315,000 for the purchase of a Vacuum Street Sweeper to be used by the Public Works Department during street cleaning operations.

Thank you for your consideration of this matter.

Sincerely,



Jim McGonagle
Commissioner of Public Works

Jim McGonagle
Commissioner

Telephone: (617) 796-1009 • Fax: (617) 796-1050 • jmcgonagle@newtonma.gov

C.N. WOOD CO., INC.
CONTRACTORS' EQUIPMENT

Presents a Proposal Summary

of the



Whirlwind

Whirlwind Pure Vacuum Street Sweeper with Fluid Coupler Drive and Dual Side Brooms

for

City of Newton

August 2019

PRODUCT DESCRIPTION

· Tier 4F emissions, 8 cubic yard hopper, 36 in. trailing arm side brooms on both right and left hand sides, ergonomic control console, sweeper is powder coated with powder coated gray undercarriage.

STANDARD FEATURES

- Auxiliary Engine:
- John Deere 4045T, 4-cylinder Turbocharged diesel
- Alternator, 120 amp.
- Horsepower: 74 HP (55 kW at 2400 RPM torque 224 lb-ft @1600 RPM
- Displacement: 276 cu. in. (4.5 L)
- Auto Shutdown Auxiliary Engine
- Backup alarm, electric
- Broom Measurement Ruler
- Camera, Rear View
- Drive: Fluid coupling blower drive with power belt
- Doors, fiberglass access doors provide easy service and maintenance on auxiliary engine, hydraulic and electrical system
- Electronic Throttle
- Fuel tank, 50 gallons (189 L)
- Fuel water separator for auxiliary engine
- Hose, hydrant fill, 16 ft 8 inches with coupling
- Hopper rear door, hydraulically opened/closed and locked/unlocked with external controls
- Hydraulic oil cooler
- In cab hopper dump
- LED clearance lights
- AM/FM/CD Radio
- Left Hand Fender Mirror
- Right and Left Hand Heated and Remote Controlled Mirrors
- Sweeper Painted Standard White
- Chassis Painted Standard White
- Red Logo
- 1 Year Parts and Labor Warranty

ADDITIONAL FEATURES

- 2020 Freightliner M2 Chassis - Dual Steer
- Cameras – RH and LH Sides
- Auto Shutter Right Hand
- Auto Shutter Left Hand
- Lifeliner Hopper System
- Stainless Steel Screens
- Right Hand Inspection Door with Step and Handle
- 6" Hopper Drain
- Hydraulic Heavy-Duty Wandering Hose
- (2) 4 Ft. Aluminum Wandering Hose Extension Rear Mounted
- Front Spray Bar
- Hopper Deluge
- High Pressure Washdown
- Nozzle With 3rd Caster Wheel
- Auxiliary Hydraulic Pump
- Autolube - Sweeper Only
- Rear LED Arrowstick
- (2) Rear LED Beacons
- Sweeper Service Manual
- John Deere Service Manual
- Chassis Operators Manual
- Chassis Parts Manual
- Chassis Service Manual

Budget Price: \$315,500.00

Price valid for 30 Days from date of 8/2/2019

LIMITED WARRANTY

ELGIN SWEEPER COMPANY warrants each new machine manufactured by it against defects in material and workmanship provided the machine is used in a normal and reasonable manner. This warranty is extended only to the original user-purchaser for a period of twelve (12) months from the date of delivery to the original user-purchaser.

ELGIN SWEEPER COMPANY will cause to be repaired or replaced, as the Company, may elect, any part or part of such machine which the Company's examination discloses to be defective in material or workmanship.

Repairs or replacements are to be made at the selling Elgin distributor's location or at other locations approved by ELGIN SWEEPER COMPANY.

The ELGIN SWEEPER COMPANY warranty shall not apply to:

1. Major components or trade accessories such as but not limited to, trucks, engines, tires or batteries that have a separate warranty by the original manufacturer.
2. Normal adjustments and maintenance services.
3. Normal wear parts such as but not limited to, broom filters, broom wire, shoe runners and rubber deflectors.
4. Failures resulting from the machine being operated in a manner or for a purpose not recommended by ELGIN SWEEPER COMPANY.
5. Repairs, modifications or alterations without the consent of ELGIN SWEEPER COMPANY which, in the Company's sole judgment, have adversely affected the machine's stability or reliability.
6. Items subjected to misuse, negligence, accident or improper maintenance.

The use in the product of any part other than parts approved by ELGIN SWEEPER COMPANY may invalidate this warranty. ELGIN SWEEPER COMPANY reserves the right to determine, in its sole discretion, if the use of non-approved parts operates to invalidate the warranty.

Nothing contained in this warranty shall make ELGIN SWEEPER COMPANY liable for loss, injury, or damage of any kind to any person or entity resulting from any defect or failure in the machine.

TO THE EXTENT LIMITED BY LAW, THIS WARRANTY IS IN LIEU OF ALL OTHER WARRANTIES, EXPRESS OR IMPLIED, INCLUDING WITHOUT LIMITATION, ANY IMPLIED WARRANTIES OF MERCHANTABILITY AND FITNESS FOR A PARTICULAR PURPOSE.

This warranty is also in lieu of all other obligations or liabilities on the part of ELGIN SWEEPER COMPANY, including but not limited to, liability for incidental and consequential damages on the part of the Company or the seller.

ELGIN SWEEPER COMPANY makes no representation that the machine has the capacity to perform any functions other than as contained in the Company's written literature, catalogs or specifications accompanying delivery of the machine.

No person or affiliated company representative is authorized to give any other warranties or to assume any other liability on behalf of ELGIN SWEEPER COMPANY in connection with the sale, servicing or repair of any machine manufactured by the Company.

ELGIN SWEEPER COMPANY reserves the right to make design changes or improvements in its products without imposing any obligation upon itself to change or improve previously manufactured products.



RUTHIANNE FULLER
MAYOR

City of Newton, Massachusetts
Office of the Mayor

#293-19

Telephone
(617) 796-1100

Telefax
(617) 796-1113

TDD
(617) 796-1089

E-mail
rfuller@newtonma.gov

August 5, 2019

Honorable City Council
Newton City Hall
1000 Commonwealth Avenue
Newton Centre, MA 02459

Councilors:

I respectfully submit a docket item to your Honorable Council requesting authorization to appropriate and expend \$150,280 and authorize a general obligation borrowing of an equal amount for the purchase of two Ford F550 4x4 trucks to be used by the Highway Department during street and snow operations.

Further, I request that your Honorable Council authorize any premium received upon the sale of the bonds or notes, less the cost of preparing, issuing and marketing them, and any accrued interest received upon the delivery of the bonds or notes be applied to the costs of the project being financed by the bonds or notes and to reduce the amount authorized to be borrowed for the project by a like amount.

Thank you for your consideration of this matter.

Sincerely,

Ruthanne Fuller
Mayor

RECEIVED
CITY CLERK
2019 AUG -5 PM 4: 14
David A. Green, Clerk
Newton, MA 02459

City of Newton



DEPARTMENT OF PUBLIC WORKS

OFFICE OF THE COMMISSIONER

1000 Commonwealth Avenue
Newton Centre, MA 02459-1449

Ruthanne Fuller

Mayor

To: Mayor Ruthanne Fuller
Maureen Lemieux, CFO

From: Jim McGonagle

Subject: (2) Highway 6 Wheel Dump Truck

Date: 7/29/19

I write to request that the Honorable Council docket for consideration a request to authorize the appropriation of \$150,280 for the purchase of two Ford F550 4x4 trucks to be used by the Highway Department during street and snow operations. Please see attached backup.

Thank you for your consideration of this matter.

Sincerely,

Jim McGonagle
Commissioner of Public Works

Jim McGonagle
Commissioner

Telephone: (617) 796-1009 • Fax: (617) 796-1050 • jmcgonagle@newtonma.gov



Minuteman Truck Sales, Inc.
2181 Providence Highway, Walpole,
Massachusetts, 020812528
Office: 508-668-3112

Customer Proposal

Prepared by:
Dominick LaGambina
Office: 508-668-3112
Email: dlagambina@minutemantrucks.com

Date: 07/15/2019
Vehicle: 2020 F-550 Chassis XL
4x4 SD Regular Cab 145" WB DRW Quote
ID: Newton 43 & 45

2020 F-550 Chassis 4x4 SD Regular Cab 145" WB DRW XL (F5H)

Price Level: 950



Client Proposal

Prepared by:
Dominick LaGambina
Office: 508-668-3112
Quote ID: New4345
Date: 07/15/2019





Prepared by: Dominick LaGambina
07/15/2019

Minuteman Trucks, Inc. | 2181 Providence Highway Walpole Massachusetts |
020812528

2020 F-550 Chassis 4x4 SD Regular Cab 145" WB DRW XL (F5H)

Price Level: 950 | Quote ID: New4345

Selected Equip & Specs

Dimensions

- Exterior length: 230.7" • Cab to axle: 60.0" • Exterior width: 80.0" • Exterior height: 81.5" • Wheelbase: 145.0" • Front track: 74.8" • Rear track: 74.0" • Turning radius: 21.2' • Rear tire outside width: 93.9" • Min ground clearance: 8.2" • Front legroom: 43.9" • Front headroom: 40.8" • Front hiproom: 62.5" • Front shoulder room: 66.7" • Passenger volume: 64.6cu.ft.
- Cargo volume: 11.6cu.ft. • Maximum cargo volume: 11.6cu.ft.

Powertrain

- 288hp 6.8L SOHC 30 valve V-10 engine with SMPI • Recommended fuel : regular unleaded • federal • TorqShift 6 speed automatic transmission with overdrive • Part-time * **Limited slip differential** • Fuel Economy Cty: N/A • Fuel Economy Highway: N/A

Suspension/Handling

- Front Mono-beam non-independent suspension with anti-roll bar, HD shocks * **Rear DANA 130 rigid axle leaf spring suspension with anti-roll bar, HD shocks** • Firm ride Suspension • Hydraulic power-assist re-circulating ball Steering • Front and rear 19.5 x 6 argent steel wheels * **LT225/70SR19.5 GBSW AT front and rear tires** • Dual rear wheels

Body Exterior

- 2 doors * **Driver and passenger power remote heated, manual folding door mirrors with turn signal indicator * Turn signal indicator in mirrors** • Black door mirrors * **Chrome bumpers * Side steps** • Trailer harness • Clearcoat paint • Front and rear 19.5 x 6 wheels • 2 front tow hook(s)

Convenience

- Manual air conditioning with air filter * **Cruise control with steering wheel controls * Power front windows * Driver and passenger 1-touch up * Driver and passenger 1-touch down * Remote power door locks with 2 stage unlock and illuminated entry** • Manual tilt steering wheel • Manual telescopic steering wheel * **Day-night rearview mirror with auto-dimming * 911 Assist emergency SOS * Wireless phone connectivity * AppLink smart device integration * 2 1st row LCD monitors** • Front cupholders • Passenger visor mirror * **Driver and passenger door bins** • Upfitter switches

Seats and Trim

- Seating capacity of 3 • Front 40-20-40 split-bench seat • 4-way driver seat adjustment • Manual driver lumbar support • 4-way passenger seat adjustment • Centre front armrest with storage

Entertainment Features

- AM/FM stereo radio * **SYNC external memory control * Steering wheel mounted radio controls** • 4 speakers * **Streaming audio** • Fixed antenna

Lighting, Visibility and Instrumentation

- Halogen aero-composite headlights • Delay-off headlights • Fully automatic headlights • Variable intermittent front windshield wipers * **Rear window defroster * Deep tinted windows** • Front reading lights • Tachometer • Oil pressure gauge * **Compass** • Outside temperature display * **Camera(s) - rear** • Trip computer • Trip odometer

Prices and content availability as shown are subject to change and should be treated as estimates only. Actual base vehicle, package and option pricing may vary from this estimate because of special local pricing, availability or pricing adjustments not reflected in the dealer's computer system. See salesperson for the most current information.



Prepared by: Dominick LaGambina
07/15/2019

Minuteman Trucks, Inc. | 2181 Providence Highway Walpole Massachusetts |
020812528

2020 F-550 Chassis 4x4 SD Regular Cab 145" WB DRW XL (F5H)

Price Level: 950 | Quote ID: New4345

Selected Equip & Specs (cont'd)

Safety and Security

• 4-wheel ABS brakes • Brake assist • 4-wheel disc brakes • Driveline traction control • Dual front impact airbag supplemental restraint system with passenger cancel • Dual seat mounted side impact airbag supplemental restraint system • Safety Canopy System curtain 1st row overhead airbag supplemental restraint system * **Remote activated perimeter/approach lighting** * **Power remote door locks with 2 stage unlock and panic alarm** * **Security system with SecuriLock immobilizer** * **MyKey restricted driving mode** • Manually adjustable front head restraints

Dimensions

General Weights

* Curb	7,289 lbs.	* GVWR	19,000 lbs.
* Payload	12,000 lbs.		

Front Weights

* Front GAWR	7,500 lbs.	* Front curb weight	4,060 lbs.
* Front axle capacity	7,500 lbs.	* Front spring rating	7,500 lbs.
Front tire/wheel capacity	7,500 lbs.		

Rear Weights

Rear GAWR	13,660 lbs.	* Rear curb weight	3,229 lbs.
* Rear axle capacity	14,706 lbs.	* Rear spring rating	15,000 lbs.
Rear tire/wheel capacity	15,000 lbs.		

Trailer Type

Harness	Yes	* Brake controller	Yes
Trailer sway control	Yes		

General Trailing

5th-wheel towing capacity	20300 lbs.	Gooseneck towing capacity	20300 lbs.
Towing capacity	18500 lbs.	GCWR	28000 lbs.

Fuel Tank type

Capacity	40 gal.
----------	---------

Off Road

Min ground clearance	8 "
----------------------	-----

Interior cargo

Cargo volume	11.6 cu.ft.	Maximum cargo volume	11.6 cu.ft.
--------------	-------------	----------------------	-------------

Rear Frame

Height loaded	29 "	Height unloaded	35 "
---------------	------	-----------------	------

Powertrain

Prices and content availability as shown are subject to change and should be treated as estimates only. Actual base vehicle, package and option pricing may vary from this estimate because of special local pricing, availability or pricing adjustments not reflected in the dealer's computer system. See salesperson for the most current information.



Prepared by: Dominick LaGambina
07/15/2019

Minuteman Trucks, Inc. | 2181 Providence Highway Walpole Massachusetts |
020812528

2020 F-550 Chassis 4x4 SD Regular Cab 145" WB DRW XL (F5H)

Price Level: 950 | Quote ID: New4345

Selected Equip & Specs (cont'd)

Engine Type

Block material	Iron	Cylinders	V-10
Head material	Aluminum	Ignition	Spark
Injection	Sequential MPI	Liters	6.8L
Orientation	Longitudinal	Recommended fuel	Regular unleaded
Valves per cylinder	3	Valvetrain	SOHC

Engine Spec

Bore	3.55"	Compression ratio	9.2:1
Displacement	415 cu.in.	Stroke	4.16"

Engine Power

Output	288 HP @ 4,000 RPM	Torque	424 ft.-lb @ 3,000 RPM
--------	--------------------	--------	------------------------

Alternator

Type	HD	Amps	240
------	----	------	-----

Battery

Amp hours	78	Cold cranking amps	750
Run down protection	Yes	Type	HD

Transmission

Electronic control	Yes	Lock-up	Yes
Overdrive	Yes	Speed	6
Type	Automatic		

Transmission Gear Ratios

1st	3.974	2nd	2.318
3rd	1.516	4th	1.149
5th	0.858	6th	0.674
Reverse Gear ratios	3.128		

Transmission Torque Converter

Stall ratio	1.90
-------------	------

Transmission Extras

Driver selectable mode	Yes	Sequential shift control	SelectShift
Oil cooler	Regular duty		

Drive Type

4wd type	Part-time	Type	Four-wheel
----------	-----------	------	------------

Drive Feature

* Limited slip differential	Mechanical	Traction control	Driveline
Locking hub control	Manual	Transfer case shift	Manual

Prices and content availability as shown are subject to change and should be treated as estimates only. Actual base vehicle, package and option pricing may vary from this estimate because of special local pricing, availability or pricing adjustments not reflected in the dealer's computer system. See salesperson for the most current information.



Prepared by: Dominick LaGambina
07/15/2019

Minuteman Trucks, Inc. | 2181 Providence Highway Walpole Massachusetts |
020812528

2020 F-550 Chassis 4x4 SD Regular Cab 145" WB DRW XL (F5H)

Price Level: 950 | Quote ID: New4345

Selected Equip & Specs (cont'd)

Drive Axle

Ratio 4.88

Exhaust

Material Stainless steel System type Single

Emissions

CARB Federal

Fuel Economy

Fuel type Gasoline

Driveability

Brakes

ABS 4-wheel ABS channels 3
Type 4-wheel disc Vented discs Front and rear

Brake Assistance

Brake assist Yes

Suspension Control

Ride Firm

Front Suspension

Independence Mono-beam non-independent Anti-roll bar Regular

Front Spring

Type Coil *Grade HD

Front Shocks

Type HD

Rear Suspension

*Independence DANA 130 rigid axle Type Leaf
Anti-roll bar Regular

Rear Spring

Type Leaf Grade HD

Rear Shocks

Type HD

Steering

Activation Hydraulic power-assist Type Re-circulating ball

Steering Specs

of wheels 2

Prices and content availability as shown are subject to change and should be treated as estimates only. Actual base vehicle, package and option pricing may vary from this estimate because of special local pricing, availability or pricing adjustments not reflected in the dealer's computer system. See salesperson for the most current information.



Prepared by: Dominick LaGambina
07/15/2019

Minuteman Trucks, Inc. | 2181 Providence Highway Walpole Massachusetts |
020812528

2020 F-550 Chassis 4x4 SD Regular Cab 145" WB DRW XL (F5H)

Price Level: 950 | Quote ID: New4345

Selected Equip & Specs (cont'd)

Exterior

Front Wheels

Diameter	19.5"	Width	6.00"
----------	-------	-------	-------

Rear Wheels

Diameter	19.5"	Width	6.00"
Dual	Yes		

Spare Wheels

* Wheel material **Steel**

Front and Rear Wheels

Appearance	Argent	Material	Steel
------------	--------	----------	-------

Front Tires

Aspect	70	Diameter	19.5"
Sidewalls	BSW	Speed	S
* Tread	AT	Type	LT
Width	225mm	LT load rating	G
* RPM	645		

Rear Tires

Aspect	70	Diameter	19.5"
Sidewalls	BSW	Speed	S
* Tread	AT	Type	LT
Width	225mm	LT load rating	G
* RPM	645		

Spare Tire

* Mount	Frame mounted	* Type	Full-size
---------	----------------------	--------	------------------

Wheels

Front track	74.8"	Rear track	74.0"
Turning radius	21.2'	Wheelbase	145.0"
Rear tire outside width	93.9"		

Body Features

Front license plate bracket	Yes	Front splash guards	Yes
Body material	Aluminum	Side impact beams	Yes
* Side steps	Yes	Front tow hook(s)	2

Body Doors

Door count	2
------------	---

Exterior Dimensions

Prices and content availability as shown are subject to change and should be treated as estimates only. Actual base vehicle, package and option pricing may vary from this estimate because of special local pricing, availability or pricing adjustments not reflected in the dealer's computer system. See salesperson for the most current information.



Prepared by: Dominick LaGambina
07/15/2019

Minuteman Trucks, Inc. | 2181 Providence Highway Walpole Massachusetts |
020812528

2020 F-550 Chassis 4x4 SD Regular Cab 145" WB DRW XL (F5H)

Price Level: 950 | Quote ID: New4345

Selected Equip & Specs (cont'd)

Length	230.7"	Body width	80.0"
Body height	81.5"	Cab to axle	60.0"
Axle to end of frame	47.2"	* Frame section modulus	17.2cu.in.
Frame yield strength (psi)	50000.0	Frame rail width	34.2"
Front bumper to Front axle	38.3"	Cab to end of frame	107.2"
Front bumper to back of cab	123.7"		

Safety

Airbags

Driver front-impact	Yes	Driver side-impact	Seat mounted
Overhead Safety Canopy System curtain 1st row		Passenger front-impact	Cancellable
Passenger side-impact	Seat mounted		

Seatbelt

Height adjustable	Front
-------------------	-------

Security

* Immobilizer	SecuriLock	* Panic alarm	Yes
* Restricted driving mode	MyKey		

Seating

Passenger Capacity

Capacity	3
----------	---

Front Seats

Split	40-20-40	Type	Split-bench
-------	----------	------	-------------

Driver Seat

Fore/aft	Manual	Reclining	Manual
Way direction control	4	Lumbar support	Manual

Passenger seat

Fore/aft	Manual	Reclining	Manual
Way direction control	4		

Front Head Restraint

Control	Manual	Type	Adjustable
---------	--------	------	------------

Front Armrest

Centre	Yes	Storage	Yes
--------	-----	---------	-----

Front Seat Trim

Material	Vinyl	Back material	Vinyl
----------	-------	---------------	-------

Prices and content availability as shown are subject to change and should be treated as estimates only. Actual base vehicle, package and option pricing may vary from this estimate because of special local pricing, availability or pricing adjustments not reflected in the dealer's computer system. See salesperson for the most current information.



Prepared by: Dominick LaGambina
07/15/2019

Minuteman Trucks, Inc. | 2181 Providence Highway Walpole Massachusetts |
020812528

2020 F-550 Chassis 4x4 SD Regular Cab 145" WB DRW XL (F5H)

Price Level: 950 | Quote ID: New4345

Selected Equip & Specs (cont'd)

Convenience

AC And Heat Type

Air conditioning Manual Air filter Yes

Audio System

Radio AM/FM stereo Radio grade Regular
Seek-scan Yes * External memory control SYNC

Audio Speakers

Speaker type Regular Speakers 4

Audio Controls

* Steering wheel controls Yes * Voice activation Yes
* Streaming audio Bluetooth yes

Audio Antenna

Type Fixed

LCD Monitors

* 1st row 2 * Primary monitor size (inches) 4.2

Cruise Control

* Cruise control With steering wheel controls

Convenience Features

* Retained accessory power Yes 12V DC power outlet 2
* Emergency SOS 911 Assist * Wireless phone connectivity Bluetooth
* AC power outlet 1 * Smart device integration App link
Upfitter switches Yes

Door Lock Activation

* Type Power with 2 stage unlock * Remote Keyfob (all doors)
* Integrated key/remote Yes

Instrumentation Type

Display Analog

Instrumentation Gauges

Tachometer Yes Oil pressure Yes
Engine temperature Yes Transmission fluid temp Yes
Engine hour meter Yes

Instrumentation Warnings

Oil pressure Yes Engine temperature Yes
Battery Yes Lights on Yes

Prices and content availability as shown are subject to change and should be treated as estimates only. Actual base vehicle, package and option pricing may vary from this estimate because of special local pricing, availability or pricing adjustments not reflected in the dealer's computer system. See salesperson for the most current information.



Prepared by: Dominick LaGambina
07/15/2019

Minuteman Trucks, Inc. | 2181 Providence Highway Walpole Massachusetts |
020812528

2020 F-550 Chassis 4x4 SD Regular Cab 145" WB DRW XL (F5H)

Price Level: 950 | Quote ID: New4345

Selected Equip & Specs (cont'd)

Key	Yes	Low fuel	Yes
Door ajar	Yes	Service interval	Yes
Brake fluid	Yes		

Instrumentation Displays

Clock	In-radio display	* Compass	Yes
Exterior temp	Yes	Systems monitor	Yes
* Camera(s) - rear	Yes		

Instrumentation Feature

Trip computer	Yes	Trip odometer	Yes
---------------	-----	---------------	-----

Steering Wheel Type

Material	Urethane	Tilting	Manual
Telescoping	Manual		

Front Side Windows

* Window 1st row activation	Power
-----------------------------	-------

Window Features

* 1-touch down	Driver and passenger	* 1-touch up	Driver and passenger
* Tinted	Deep		

Front Windshield

Wiper	Variable intermittent
-------	-----------------------

Rear Windshield

* Defroster	Yes	Window	Fixed
-------------	-----	--------	-------

Interior

Passenger Visor

Mirror	Yes
--------	-----

Rear View Mirror

Day-night	Yes	* Auto-dimming	Yes
-----------	-----	----------------	-----

Headliner

Coverage	Full	Material	Cloth
----------	------	----------	-------

Floor Trim

Coverage	Full	Covering	Vinyl/rubber
----------	------	----------	--------------

Trim Feature

Gear shift knob	Urethane	Interior accents	Chrome
-----------------	----------	------------------	--------

Lighting

Dome light type	Fade	Front reading	Yes
-----------------	------	---------------	-----

Prices and content availability as shown are subject to change and should be treated as estimates only. Actual base vehicle, package and option pricing may vary from this estimate because of special local pricing, availability or pricing adjustments not reflected in the dealer's computer system. See salesperson for the most current information.



Prepared by: Dominick LaGambina
07/15/2019

Minuteman Trucks, Inc. | 2181 Providence Highway Walpole Massachusetts |
020812528

2020 F-550 Chassis 4x4 SD Regular Cab 145" WB DRW XL (F5H)

Price Level: 950 | Quote ID: New4345

Selected Equip & Specs (cont'd)

* Illuminated entry	Yes	Variable IP lighting	Yes
<i>Storage</i>			
* Driver door bin	Yes	Front Beverage holder(s)	Yes
Glove box	Locking	* Passenger door bin	Yes
Illuminated	Yes	Instrument panel	Bin
Dashboard	Covered		
<i>Legroom</i>			
Front	43.9"		
<i>Headroom</i>			
Front	40.8"		
<i>Hip Room</i>			
Front	62.5"		
<i>Shoulder Room</i>			
Front	66.7"		
<i>Interior Volume</i>			
Passenger volume	64.6 cu.ft.		

Prices and content availability as shown are subject to change and should be treated as estimates only. Actual base vehicle, package and option pricing may vary from this estimate because of special local pricing, availability or pricing adjustments not reflected in the dealer's computer system. See salesperson for the most current information.



Prepared by: Dominick LaGambina
07/15/2019

Minuteman Trucks, Inc. | 2181 Providence Highway Walpole Massachusetts |
020812528

2020 F-550 Chassis 4x4 SD Regular Cab 145" WB DRW XL (F5H)

Price Level: 950 | Quote ID: New4345

Warranty

Standard Warranty

Basic

Distance 36,000 miles Months 36 months

Powertrain

Distance 60,000 miles Months 60 months

Corrosion Perforation

Distance Unlimited miles Months 60 months

Roadside Assistance

Distance 60,000 miles Months 60 months

Prices and content availability as shown are subject to change and should be treated as estimates only. Actual base vehicle, package and option pricing may vary from this estimate because of special local pricing, availability or pricing adjustments not reflected in the dealer's computer system. See salesperson for the most current information.



Prepared by: Dominick LaGambina
07/15/2019

Minuteman Trucks, Inc. | 2181 Providence Highway Walpole Massachusetts |
020812528

2020 F-550 Chassis 4x4 SD Regular Cab 145" WB DRW XL (F5H)

Price Level: 950 | Quote ID: New4345

As Configured Vehicle

Description

Base Vehicle

Base Vehicle Price (F5H)

Packages

Order Code 660A

Includes:

- Engine: 6.8L 3-Valve SOHC EFI NA V10
- Transmission: TorqShift 6-Speed Automatic (6R140)
Includes SelectShift.
- Wheels: 19.5" Argent Painted Steel
Includes manual locking hubs.
- HD Vinyl 40/20/40 Split Bench Seat
Includes center armrest, cupholder, storage and driver's side manual lumbar.

Powertrain

Engine: 6.8L 3-Valve SOHC EFI NA V10

Transmission: TorqShift 6-Speed Automatic (6R140)

Includes SelectShift.

Limited Slip w/4.88 Axle Ratio

GVWR: 19,000 lbs Payload Upgrade Package

Includes upgraded frame and upgraded rear-axle. Note: See Order Guide Supplemental Reference for further details on GVWR and payload ranges.

Wheels & Tires

Tires: 225/70Rx19.5G BSW Traction (TGK)

Includes 4 traction tires on the rear and 2 traction tires on the front. Not recommended for over the road applications; could incur irregular front tire wear and/or NVH. Optional spare is 225/70Rx19.5G BSW traction.

Wheels: 19.5" Argent Painted Steel

Includes manual locking hubs.

Spare Tire, Wheel & Jack

Required in Rhode Island.

Excludes carrier.

Includes:

- 6-Ton Hydraulic Jack

Seats & Seat Trim

HD Vinyl 40/20/40 Split Bench Seat

Includes center armrest, cupholder, storage and driver's side manual lumbar.

Other Options

Prices and content availability as shown are subject to change and should be treated as estimates only. Actual base vehicle, package and option pricing may vary from this estimate because of special local pricing, availability or pricing adjustments not reflected in the dealer's computer system. See salesperson for the most current information.



Prepared by: Dominick LaGambina
07/15/2019

Minuteman Trucks, Inc. | 2181 Providence Highway Walpole Massachusetts |
020812528

2020 F-550 Chassis 4x4 SD Regular Cab 145" WB DRW XL (F5H)

Price Level: 950 | Quote ID: New4345

As Configured Vehicle (cont'd)

Description

Monotone Paint Application

145" Wheelbase

XL Value Package

Includes:

- 4.2" Center-Stack Screen
- Radio: AM/FM Stereo/MP3 Player
Includes 4 speakers.
- SYNC Communications & Entertainment System
Includes enhanced voice recognition with 911 Assist, 4.2" LCD center stack screen, AppLink, 1 smart-charging USB port and steering wheel audio controls.
- Chrome Front Bumper
- Steering Wheel-Mounted Cruise Control

Power Equipment Group

Deletes passenger side lock cylinder. Includes upgraded door-trim panel.

Includes:

- Accessory Delay
- Advanced Security Pack
Includes SecuriLock Passive Anti-Theft System (PATS) and inclination/intrusion sensors.
- Trailer Tow Mirrors w/Power Heated Glass
Includes manual telescoping, heated convex spotter mirror and integrated clearance lamps/turn signals.
- MyKey
Includes owner controls feature.
- Power Front Side Windows
Includes 1-touch up/down driver/passenger window.
- Power Locks
- Remote Keyless Entry

Extra Heavy-Duty Front End Suspension - 7,500 GAWR

Includes upgraded front axle and max 7,500 lbs. Front Springs/GAWR rating for configuration selected. Incomplete vehicle package - requires further manufacture and certification by a final stage manufacturer.

Snow Plow Prep Package

Includes pre-selected springs (see Order Guide Supplemental Reference for springs/FGAWR of specific vehicle configurations). Note 1: Restrictions apply; see Supplemental Reference or Body Builders Layout Book for details. Note 2: Also allows for the attachment of a winch.

6-Ton Hydraulic Jack

Upfitter Interface Module

Utility Lighting System

Includes LED side-mirror spotlights.

Trailer Brake Controller

Includes smart trailer tow connector. Verified to be compatible with electronic actuated drum brakes only.

Platform Running Boards

Rear View Camera & Prep Kit

Upfitters kit includes camera with mounting bracket, 14' jumper wire and camera mounting and aiming instructions. Kit requires video display option to be added to unit. Reference order guide for additional information. Related option content: 872, 585 and 96V.

Includes cab wiring, frame wiring to the rear most cross member and electrochromic mirror with video display. Video displayed in 4" display.

Prices and content availability as shown are subject to change and should be treated as estimates only. Actual base vehicle, package and option pricing may vary from this estimate because of special local pricing, availability or pricing adjustments not reflected in the dealer's computer system. See salesperson for the most current information.



Prepared by: Dominick LaGambina
07/15/2019

Minuteman Trucks, Inc. | 2181 Providence Highway Walpole Massachusetts |
020812528

2020 F-550 Chassis 4x4 SD Regular Cab 145" WB DRW XL (F5H)

Price Level: 950 | Quote ID: New4345

As Configured Vehicle (cont'd)

Description

Fixed Rear-Window w/Defrost

Privacy Glass

110V/400W Outlet

Includes 1 in-dash mounted outlet.

Radio: AM/FM Stereo/MP3 Player

Includes 4 speakers.

Includes:

- SYNC Communications & Entertainment System

Includes enhanced voice recognition with 911 Assist, 4.2" LCD center stack screen, AppLink, 1 smart-charging USB port and steering wheel audio controls.

Wheel Well Liner (Pre-Installed)

Custom accessory.

Fleet Options

Steering Wheel-Mounted Cruise Control

Emissions

50-State Emissions System

Interior Colors

Medium Earth Gray

Primary Colors

Oxford White

Upfit Options

Install Knapheide Platform Body per Attached

Install Knapheide Platform Body Per Attached JC Madigan Spec for Newton Specifications

Keys 5 Keys per spec

Keys 5 Keys per Spec

GPS

GPS per City of Newton Specifications

Install Newton Graphic Package

Install Newton Graphic Package per Spec

Prices and content availability as shown are subject to change and should be treated as estimates only. Actual base vehicle, package and option pricing may vary from this estimate because of special local pricing, availability or pricing adjustments not reflected in the dealer's computer system. See salesperson for the most current information.

450 Old Union Turnpike
Lancaster, MA 01523
Phone: 978-847-2900
Fax: 978-847-0068

J. C. Madigan, Inc.
Sales Dept.

Fax Quote

To: DOM L. @ MINUTEMAN **From** JOHN DWYER

Co. CITY OF NEWTON CENTRAL GARAGE **Date:** 07/11/2019

FAX# **Phone:** (617) 901-8801

Re: 9' KNAPHEIDE PVMX PLATFORM **CC:**

Urgent **For Review** **Please Comment** **Please Reply** **Please Recycle**

- Heavy Duty "KNAPHEIDE" Steel 9' 3" PVMX Series Platform
- Diamond Plate Steel Floor w/ Underside Tie Down Rail (both sides)
- 12" Removable Steel Rack Sides
- Reinforced Steel Headboard W/ Window
- Recessed LED Body Light kit & High Decibel Backup Alarm
- Undercoated & Painted Black
- Aluminum Diamond Plate I-Pak Toolbox
- Curb & Street Side Black Aluminum Frame Mounted Toolboxes
- Pintle Plate w/ Combo Pintle, D-Rings, 7-Spade RV Plug, & Wired in Electric Factory Brake Controls
- Trucklite # 5070 & 5071 LED Taillight Assemblies Recessed in Pintle Plate
- Poly Fenders Over the Rear Wheels w/ Rear Mud Flaps
- 9' Everest RL Poly Plow & Everest 450/550 Hitch Installed w/ Fisher Hydraulics, Fishstick Controls, Rubber Deflector, ABL LED Plow lights, Guide poles, Cutting Edge, & 36" Curb Shoes
- Weather Tech Floor Mats & Window Shades
- Factory Backup Camera Mounted at Rear
- Install Customer Supplied Electric Sander & Controls
- Atomic Brand LED Clearance Lights/Flashers Over The Cab (2) Whelen IONV3A Front Grill (4) Whelen M2WAC (2) Headlight Mtd. (2) Rear Mtd. (all on Separate switches)
- (2) ECCE W2112 LED Worklights/Backups Rear Mtd.



Prepared by: Dominick LaGambina
07/15/2019

Minuteman Trucks, Inc. | 2181 Providence Highway Walpole Massachusetts |
020812528

2020 F-550 Chassis 4x4 SD Regular Cab 145" WB DRW XL (F5H)

Price Level: 950 | Quote ID: New4345

Pricing Summary

TOTAL per UNIT: \$75,140.00

Total for qty (2): \$150,280.00

Total Contract Price / PO Required for Qty 2: \$150,280.00

Customer Signature

Acceptance Date

Prices and content availability as shown are subject to change and should be treated as estimates only. Actual base vehicle, package and option pricing may vary from this estimate because of special local pricing, availability or pricing adjustments not reflected in the dealer's computer system. See salesperson for the most current information.



2020 F-550 Chassis 4x4 SD Regular Cab 145" WB DRW XL (F5H)

Price Level: 950 | Quote ID: New4345

Vehicle Dimension and Performance Summary

Performance predictions in this report represent an estimate of vehicle performance based on standard operating conditions. Variations in customer equipment, load configuration, ambient conditions, and/or operator driving techniques can cause significant variations in vehicle performance. These values are not representative of results that may be shown in actual dynamometer tests. This report should therefore be used as a guide for comparative vehicle performance.

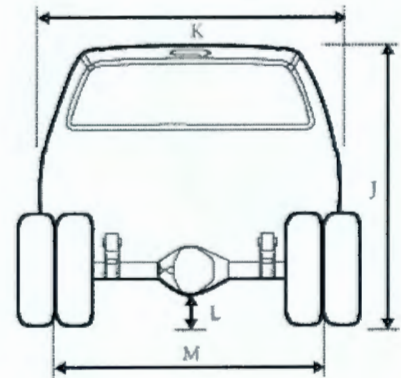
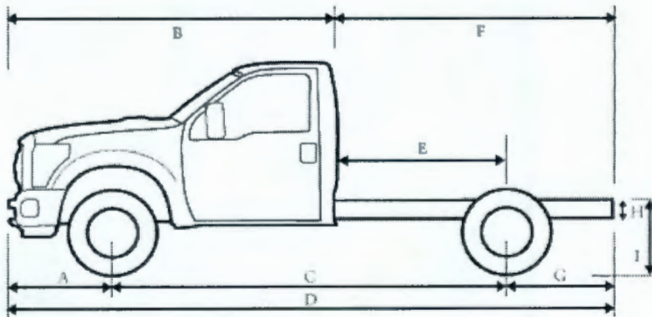

Dimensions

A	Front of Bumper to Front Axle	38.30 in.
B	Front Bumper to Back of Cab (BBC)	123.70 in.
C	Wheelbase (WB)	145.00 in.
D	Overall Length (OAL)	230.70 in.
E	Back of Cab to Rear Axle (CA)	60.00 in.
F	Back of Cab to End of Frame	107.20 in.
G	Rear Axle to End of Frame (AF)	47.20 in.
H	Frame Section Height	N/A
I	Rear Frame Height Unloaded	35.10 in.
I	Rear Frame Height Loaded	28.60 in.
J	Cab Height	81.50 in.
K	Body Width	80.00 in.
L	Maximum Ground Clearance	N/A
L	Minimum Ground Clearance	8.20 in.
M	Front Tread	74.80 in.
M	Rear Tread	74.00 in.



Prepared by: Dominick LaGambina
07/15/2019

Minuteman Trucks, Inc. | 2181 Providence Highway Walpole Massachusetts |
020812528

2020 F-550 Chassis 4x4 SD Regular Cab 145" WB DRW XL (F5H)

Price Level: 950 | Quote ID: New4345

Vehicle Dimension and Performance Summary (cont'd)

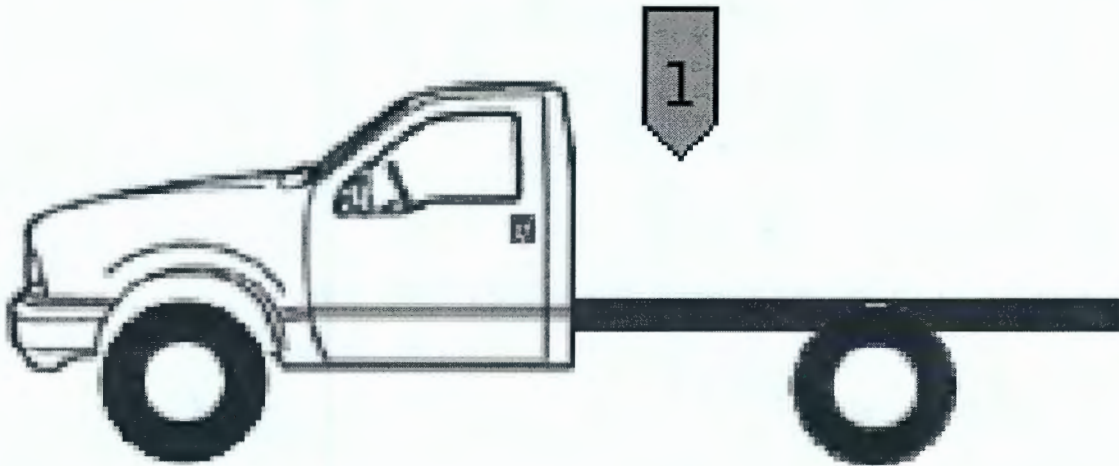

Weight

GVW	Front Axle	Rear Axle	Totals
Chassis	4,063 lbs	3,231 lbs	7,294 lbs
Body	0 lbs	0 lbs	0 lbs
Occupants Weight	300 lbs	150 lbs	450 lbs
1 Max Payload - (Max Payload)	3,137 lbs	8,119 lbs	11,256 lbs
TOTAL	7,500 lbs	11,500 lbs	19,000 lbs

Ratings	Front Axle	Rear Axle	GVWR
GAWR	7,500 lbs	13,660 lbs	19,000 lbs
Wheels/Tires	7,500 lbs	15,000 lbs	
Suspension	7,500 lbs	15,000 lbs	
Axle	7,500 lbs	14,706 lbs	
Legal Axle Limit	0 lbs	0 lbs	

Prices and content availability as shown are subject to change and should be treated as estimates only. Actual base vehicle, package and option pricing may vary from this estimate because of special local pricing, availability or pricing adjustments not reflected in the dealer's computer system. See salesperson for the most current information.



Prepared by: Dominick LaGambina
07/15/2019

Minuteman Trucks, Inc. | 2181 Providence Highway Walpole Massachusetts |
020812528

2020 F-550 Chassis 4x4 SD Regular Cab 145" WB DRW XL (F5H)

Price Level: 950 | Quote ID: New4345

Vehicle Dimension and Performance Summary (cont'd)

Start, Grade and Speed

Start	Ratio	Desired	Calculated
Start grade capability in 1st gear	3.97	15.00 %	24.78 %
Start grade capability in reverse	3.13	15.00 %	19.51 %
Grade	Ratio	Desired	Calculated
Maximum grade in 4th gear	1.15	3.00 %	7.54 %
Maximum grade in 5th gear	0.86	3.00 %	5.63 %
Maximum grade in 6th gear	0.67	3.00 %	4.42 %
Speed		Desired	Calculated
Top Speed (level grade)		75 mph	85 mph
<i>To meet your requirement you need a maximum axle ratio of 8.83</i>			
Top Speed on 3.0% grade		55 mph	
<i>To meet your requirement you need a maximum of 120 hp</i>			
Cruise Speed		60 mph	74 mph
Engine RPM at desired cruise speed			2,121 rpm

Variables in Use

Rear axle ratio:	4.88/4.88	Peak Torque RPM:	3,000 rpm
Tire size:	225/70R19.5 (645 rev/mile)	Frontal Area:	40.28 Sq.Ft.
Gross Vehicle Weight (GVW):	19,000 lbs	Cruising RPM	2,600 rpm
Clutch engagement torque:	212 ft.lbs.	Worst road surface	Typical Highway
Torque conversion ratio:	1.90	Final Drive Ratio:	0.67
Peak engine torque:	424 ft.lbs.	Drag Coefficient	0.80
Engine Power:	288 hp @ 4,000 rpm		

Prices and content availability as shown are subject to change and should be treated as estimates only. Actual base vehicle, package and option pricing may vary from this estimate because of special local pricing, availability or pricing adjustments not reflected in the dealer's computer system. See salesperson for the most current information.



Prepared by: Dominick LaGambina
07/15/2019

Minuteman Trucks, Inc. | 2181 Providence Highway Walpole Massachusetts |
020812528

2020 F-550 Chassis 4x4 SD Regular Cab 145" WB DRW XL (F5H)

Price Level: 950 | Quote ID: New4345

Vehicle Dimension and Performance Summary (cont'd)

Shift Chart

Shift Chart displays mathematical geared speed.

Diesel engines use Governed RPM for shift points.

Gas engines use Peak Torque RPM for shift points.

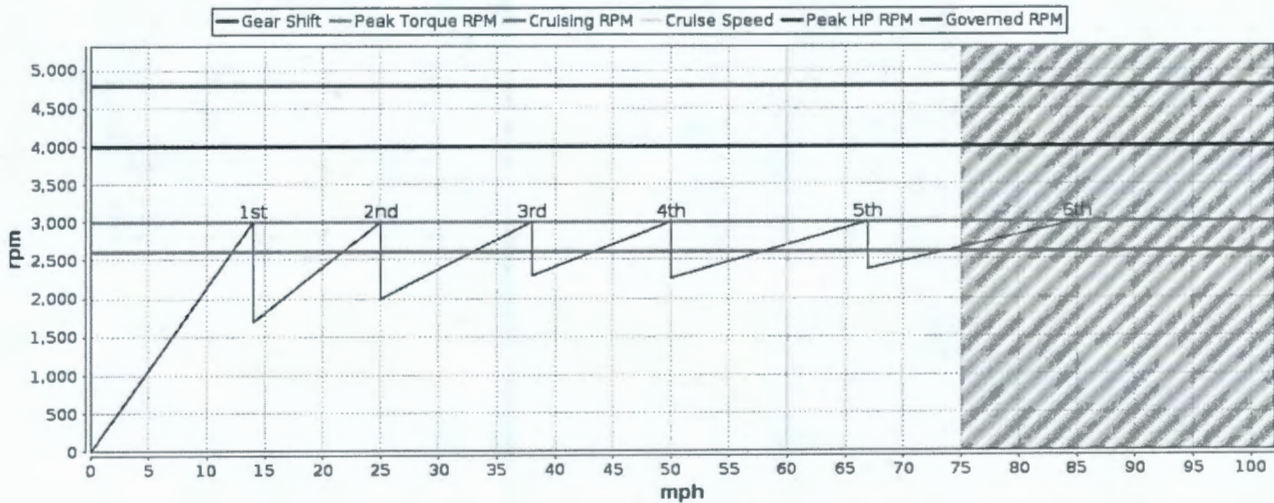

Turning Radius

Turning Radius 21.25 ft

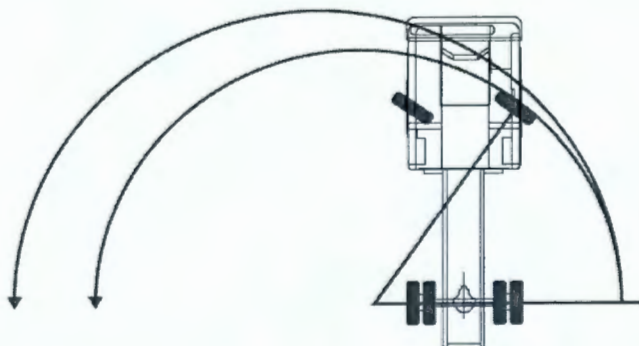

Prices and content availability as shown are subject to change and should be treated as estimates only. Actual base vehicle, package and option pricing may vary from this estimate because of special local pricing, availability or pricing adjustments not reflected in the dealer's computer system. See salesperson for the most current information.

Newton Highway #43+ #45 Provided by: Minuteman Trucks and JC Madigan
Request for Quote: (2 trucks) 2020 Ford F-550 XL Super Duty DRW

Dealer:

- Oxford white cab, all grey interior
- 2 Door regular cab
- Regular gas unleaded V10 6.8L
- 6 speed automatic transmission w/OD
- Manual shift 4WD, auto locking hubs (electronic SOTF not offered for F550 regular cab w/gas engine)
- Upgrade to 19,500lb GVWR- 4.88 limited slip rear end (as required with 19,500 payload package)
- 40/20/40 grey vinyl split bench seat, vinyl floor
- Factory air conditioning
- Factory AM/FM stereo with clock
- Factory power windows and door locks, power heated extendable tow mirrors w/ puddle lights
- Factory upfitter module controlled by factory mounted switches
- Factory black platform running boards
- Factory front wheel well liners
- Factory front splash guards
- LT 225/70R19.5 All terrain tires mounted on painted silver steel wheels, full size tire/rim
- Factory towing package including factory trailer brake controller and wire harness, 7-pin spade trailer electrical connection
- Factory back up camera provision prep kit (camera itself to be mounted by body builder)
- Factory back up alarm
- Factory LED roof clearance lights
- Factory 110V/440W interior outlet
- Factory snow plow prep package
- HD alternator
- Fixed rear window w/ defrost
- No CHMSL (blocked by I-pack)
- Factory front splash guards
- 5 total sets of keys
- City specified graphics package through Municipal Graphics in Wrentham- \$800 allowance
- City specified GPS system through AAT- \$300 allowance for parts only

Body Builder:

- Knapheide Westerner 9' black stake body w/BH bulkhead w/3rd brake/flasher cutout, 6" sideboards, underbody sliding tie-down channels and rails. All LED lights.
- HD Aluminum I-pack
- Curbside and streetside underbody toolboxes to completely fill gaps (largest possible), black aluminum diamond plate
- Rear pintle plate with tow rings and HD pintle, Truck-lite LED plate lamp, Truck-lite LED tail lamps (#5070,#5071) mounted inside the pintle plate, 7-prong spade (RV) trailer connector

- Atomic clearance lamp flashers amber w/clear lens. (2) Whelen M2WAC mounted next to headlamps. (2) Whelen IONV3A mounted in grille. (2) Rear bumper mounted Whelen M2WAC flashers. (2) LED rear spot lamps on chassis. (5) total switches- all grill flashers, clearance lamp flashers, all rear facing flashers, rear spot lamps
- Rear poly fender kit and rear mudflaps
- Ford window vent shades, Weathertech all weather floor liners
- Mount back up camera provided by Ford factory prep kit
- Everest 9' RL electric-over-hydraulic snow plow package; including electrical isolation module for lights, rubber deflector foil, steel 5/8" cutting edge, 36" blade guides, ABL LED plow lamps, remote handheld plow controls
- Install City provided electric Meyer sander and controller setup, not responsible for sander operation itself



RUTHIANNE FULLER
MAYOR

City of Newton, Massachusetts

Office of the Mayor

#294-19

Telephone
(617) 796-1100

Telefax
(617) 796-1113

TDD
(617) 796-1089

E-mail
rfuller@newtonma.gov

August 5, 2019

Honorable City Council
Newton City Hall
1000 Commonwealth Avenue
Newton Centre, MA 02459

Councilors:

I respectfully submit a docket item to your Honorable Council requesting authorization to appropriate and expend \$739,059 and authorize a general obligation borrowing of an equal amount for the purchase of three 6-wheel all season body trucks to be used by the Highway Department during street and snow operations.

Further, I request that your Honorable Council authorize any premium received upon the sale of the bonds or notes, less the cost of preparing, issuing and marketing them, and any accrued interest received upon the delivery of the bonds or notes be applied to the costs of the project being financed by the bonds or notes and to reduce the amount authorized to be borrowed for the project by a like amount.

Thank you for your consideration of this matter.

Sincerely,

Ruthanne Fuller
Mayor

2019 AUG -5 PM 4: 14
David A. Quinn, Clerk
Newton City Hall
Newton, MA 02459

City of Newton



DEPARTMENT OF PUBLIC WORKS
OFFICE OF THE COMMISSIONER
1000 Commonwealth Avenue
Newton Centre, MA 02459-1449

Ruthanne Fuller
Mayor

To: Mayor Ruthanne Fuller
Maureen Lemieux, CFO

From: Jim McGonagle

Subject: (3) Highway 6-Wheel All Season Body Trucks

Date: 7/29/19

I write to request that the Honorable Council docket for consideration a request to authorize the appropriation of \$739,059 for the purchase of three 6-wheel all season body trucks to be used by the Highway Department during street and snow operations. Please see attached backup.

Thank you for your consideration of this matter.

Sincerely,

Jim McGonagle
Commissioner of Public Works

Jim McGonagle
Commissioner

Telephone: (617) 796-1009 • Fax: (617) 796-1050 • jmcgonagle@newtonma.gov

****You must complete this document by answering YES/No for each item contained in the specification. If you check NO you MUST provide supporting documentation with the item # and your reason for the check****

GENERAL

- The equipment required under these specifications is to be used by the City of Newton Public Works Department. The equipment shall be new, of the latest production model as evidenced by the manufacturer's published literature and it shall conform to all specifications contained herein.
- Detailed specifications of the exact equipment offered must accompany the bid. Any and all supplies, parts and/or attachments not specifically mentioned but necessary to ensure a complete and safe product shall be furnished by the successful bidder.
- The equipment shall conform in strength, quality of material, and workmanship to what is usually provided by good engineering practice. Any allied equipment shall be installed in such a manner so as not to adversely affect the original manufacturer's product.

SAFETY

- The completed equipment package shall comply with all applicable Federal and State Motor Vehicle Regulations and Safety standards and codes, and any other applicable regulations in force at the time of delivery. All applicable warnings and warning labels required by law must also be complied with accordingly.

STANDARDIZATION

- All equipment delivered under the contract resulting from these specifications will be built with identical and interchangeable parts and components.

DELIVERY

- Delivery date is an important factor in determining the award and shall be stated as part of the bid. The successful bidder shall deliver the equipment complete, serviced and ready to operate, to the City of Newton Fleet Division. Vehicles or equipment delivered without a delivery appointment will not be accepted upon delivery (617-796-1479).

WARRANTY

- All warranty work shall have a full, no cost, 100% parts and labor coverage. Pickup and delivery of the vehicle shall be included as part of any warranty repair or factory/dealer recall. A manufacturer's authorized representative shall perform the warranty work.
- In addition to the manufacturer's warranty, the awarded contractor must warranty all other allied equipment against faulty workmanship and materials for two (2) years. An official warranty contract statement or information booklet stipulating warranty terms offered must accompany the bid at the time of the bid opening and be endorsed by the manufacturer.

SPECIFICATIONS: It is the intent of this specification that the bidder shall supply three (3) truck chassis, each with a new Hiway XT# Type III combo body on 46,500lb GVWR Chassis (actual GVWR limited by 12R22.5 tires) to the City of Newton as described.

<u>Truck Chassis and Accessories</u>	<u>Compliance</u> <u>Yes/No</u>
1. 2020 Mack Granite 42FR	yes
2. Warranty: 5 Year/50,000 Mile Powertrain 2 Year/24,000 mile bumper to bumper	yes
3. Standard cab painted white	yes
4. CA length to accommodate Swaploader w/ 11' container body and spreader (96" CA)	yes
5. 16,500lb SF front axle/suspension, 30,000lb rear axle/suspension	yes
6. 20" Integral frame extensions	Yes
7. Factory frame thickness upgrade	Yes
8. 12R22.5 tires with full size spare tire on rim	yes
9. Engine: Mack MP7 derated w/ factory 3-Stage compression brake	yes
10. Allison 3000 RDS automatic transmission w/ dual PTO provision, filled w/ synthetic fluid	yes
11. Electronic factory switched rear differential lock	yes
12. Four wheel ABS air brakes	yes
13. Delco 24SI 160A alternator	yes
14. Snow plow prep package	yes
15. Cold weather aids (intake heater, battery blanket, block heater, oil pan heater)	Yes
16. Factory HVAC w/air conditioning	yes
17. Factory upfitter switches	yes
18. Power accessories: windows, door locks, mirrors, (1) 12 Volt Accessory Outlet, heated side mirrors	yes
19. Factory heated windshield	yes
20. Air suspension driver and passenger seats	yes
21. Dual air horns	yes
22. AM/FM radio w/ clock and aux input	yes
23. Driver and passenger factory aluminum boards/steps w/LED step lighting	yes
24. Poly rear fenders mounted with mudflaps	yes
25. Right and left fender mounted spot mirrors	yes
26. AAT GPS supplied as parts only- \$200 allowance	yes
27. City specified graphics package- \$1,000 allowance	yes
28. Five (5) sets of keys	yes
29. CDL safety kit: Reflective triangles, spare fuses, first aid kit, 1 Mtd 5lb fire ext	yes
Body Builder Specific:	
30. Hydraulics: Single transmission mounted gear pump PTOs w/ appropriate tankage/filtration. Tank sight glass and low oil level alarm in cab. Power beyond for future optional use.	yes
31. 11' (for 96" CA) Hiway SS XT3 type 3 spreader. Options: Front and rear SS cab shields. AR400 conveyor cover. SS underbody pan. No top grates. SS driver's side ladder. Angled side boards. 3 scuttle chutes. Electric prewet system. Speed sensors for closed loop. LED Lights. Electric Aero auto aluminum load cover system w/mesh tarp and control switch mounted to driver's seat.	yes
32. Rear pintle plate with D-rings, pintle and vertical bucket guards to protect rear plate components from dumping into loader buckets	yes

33. Color backup camera w/ LCD Display: Can be integrated with am/fm radio to replace factory radio	Yes
34. Air brake glad hands mounted high on both sides of the pintle plate w/ 7-pin spade (RV) trailer plug	Yes
35. Aftermarket electric trailer brake controller, wired to rear 7-pin RV trailer plug	Yes
36. Lights: (2) SS Rear light bars with amber flashers, STT/running lights, reverse lights. (2) Truck-lite LED tail lamps (#5070,#5071) mounted inside pintle plate.	Yes
37. Two (2) Switched rear facing LED spot lights installed at the back of the chassis facing rearward Ecco	Yes
38. Whelen Liberty II amber roof mounted lightbar	Yes
39. Plow light setup mounted to hood w/ABL LED plow lamp kit and stainless steel plow lamp pedestals, wired to factory plow lamp switch	Yes
40. Two (2) Whelen IONAW LED flashers installed on plow light brackets, not to be obstructed by plow frame	Yes
41. Back up alarm 102 dBA	Yes
42. SS tool box (1): Shall be mounted on curb side between rear of cab and rear tires, shall be installed in a manner as to meet the state guidelines for bike guards on commercial vehicles, streetside shall also meet same guidelines	Yes
43. Visual and audible body up alarm buzzer in cab w/ Buyers#B95W B/U Switch	Yes
44. 10' x 42" Tall Everest HD steel double ram cushioned snow plow, PT hitch w/ clamp jaw adapter for easy hookup	Yes
45. Cirrus closed loop ground speed controls, calibrated to correctly operate Hiway spreader as described. Custom aluminum stantion for Cirrus controller.	Yes

MACK



PRICING SUMMARY
GRANITE 42FR

VEHICLE PRICE

BASE SELLING PRICE

\$246,353.00

TAX SUMMARY

FRET

AMT. SUBJECT TO TAX

\$246,353.00

\$0.00

TOTAL SELLING PRICE (PER UNIT)

\$246,353.00

TOTAL DEAL PRICE (QTY: 3)

\$739,059.00

NEWTON CITY OF

DATE

BALLARD MACK SALES & SERVICE, INC.

DATE



#294-19



In Progress

NEWTON CITY OF
110 CRAFTS ST OF
NEWTON 00000
MA

Date 6/11/2019
Quote no. PICK2019000595A595
Your ref.

Technical Specification

Please find below the Technical Specification for your new Mack Truck(s).

GRANITE 42FR

APPLICATION PACKAGES

STANDARD GROUND CLEARANCE (most applications)

CUSTOMER/VEHICLE INFO

GRANITE 42FR

2020A Pricebook

2021 MODEL YEAR

US - WARRANTY REGISTRATION LOCATION

MUNICIPAL

ALL 50 STATES, CARB ENGINE EMISSION (US17)

Made in Macungie, PA USA

ENGLISH

DUMP TRUCK

55,000 LB (25 TONNES) GROSS COMBINATION WEIGHT

BRAKE REGULATION, STOPPING DISTANCE 94M (310FT)

GRADES <3% GREATER THAN 98% OF DRIVING DISTANCE MAX GRADE 8%

AMBIENT TEMPERATURE HOT. WARMER THAN 104 F (40 C) ALLOWED UP TO 25 HOURS PER YEAR

TURNPIKE / INTERSTATE, STARTING / OPERATING GRADES 3% MAX

ASPHALT LOADING AND / OR UNLOADING SURFACE

PICKUP & DELIVERY / SHORT HAUL SERVICE

ENGINE/TRANSMISSIONS

MP7-325M MACK 325HP @ 1400-1900 RPM (PEAK) 2100 RPM (GOV) 1260 LB-FT, US'17

3000 RDS 6-SP ALLISON GEN5 W/PROGNOSTICS, WITH PTO PROVISION

ENGINE GOVERNOR TYPE MIN-MAX

EXHAUST/EMISSIONS



#294-19



Date 6/11/2019

Quote no. PICK2019000595A595

In Progress

IDLE EMISSION CERTIFICATION, CARB (WITH DECAL LOCATED ON LOWER LH CORNER / DRIVER DOOR
CLEARTECH ONE BOX E.A.T.S. RH SIDE UNDER CAB US17
DPF COVER STAINLESS STEEL, POLISHED
SINGLE VERTICAL RIGHT SIDE CAB MOUNTED, LOWER VENTURI DIFFUSER, TURNED END
9' 6" FROM GROUND
SINGLE, BRIGHT FINISH HEAT SHIELD AND SCR COVER (IF EQUIPPED)
6.6 GALLON (25 L) 22" INTEGRAL TO LH FUEL TANK
WITHOUT DEF TANK VENTILATION FILTER
EMISSION OBD, DISPLAY ONLY, USA2018

ENGINE EQUIPMENT

11" x 30" (279 mm x 762 mm) UNDER HOOD SINGLE ELEMENT DRY TYPE W/AIR INTAKE FROM BOTH SIDES OF HOOD
INSIDE/OUTSIDE AIR INTAKE W/ IN-CAB CONTROL FOR SNOWPLOWS
BLACK ALUMINUM MOUNTED BEHIND GRILLE, WITHOUT WINTER FRONT COVER
MERITOR/WABCO 318 (18.7 CFM)
DELCO 12V 160A (24SI) BRUSH-TYPE
(3) MACK 12V 730/2190 CCA THREADED STUD
ETHYLENE GLYCOL EXTENDED LIFE COOLANT (50/50 MIX DYED RED) TO -34DEG, W/ LONG LIFE FILTER
BEHR FAN AND ELECTRONIC MODULATING VISCOUS FAN DRIVE
MACK MP7 POWERLEASH
MACK W/MANUAL DRAIN VALVE (INTEGRAL W/PRIMARY FUEL FILTER)
LH RAIL UNDER CAB FORWARD OF FUEL TANK (3 BATTERY MAX)
MOLDED PLASTIC
SILICONE RADIATOR & HEATER HOSES W/BREEZE CONSTANT TORQUE CLAMPS ON ALL COOLANT LINES
12 VOLT DELCO 39MT-MXT
CORROSION RESISTANT OIL PAN
120V 1500W ENGINE BLOCK HEATER
120V 1500W BLOCK HEATER, W/150W OIL PAN HEATER WIRED TO SAME RECEPTICAL ELECTRIC PREHEATER

CLUTCH/TRANS EQUIPMENT

ALLISON DASH MOUNTED SHIFTER W/NEUTRAL TO RANGE INHIBIT (HD SERIES)
SPICER 1760 W/COATED SPLINES
TRANSYND SYNTHETIC LUBE FOR ALLISON TRANS
FURNISH FOR ALLISON TRANSMISSION W/DIRECT MOUNT COOLER
UNIVERSAL JOINT HALF-ROUND TYPE
TRANSMISSION OUTPUT TORQUE BASIC



#294-19



In Progress

Date 6/11/2019

Quote no. PICK2019000595A595

ALUMINUM

FURNISH TC421 FOR USE W/ALLISON 3000 SERIES TRANSMISSION

FRONT AXLE EQUIPMENT

16500# (7500 KG) MACK FXL16.5 STRAIGHT SPINDLE/UNITIZED BEARINGS

MACK MULTILEAF 16500# (7500 KG) GROUND LOAD RATING

MERITOR "S" CAM TYPE 16.5" x 6" Q+

CAST IRON

DUST SHIELDS FOR FRONT AXLE

FRONT BRAKE CHAMBER MANUFACTURER, MGM

HALDEX - AUTOMATIC

FRONT BRAKE CHAMBER 30SQ INCHES (SERVICE)

FERROUS

DOUBLE ACTING TYPE

SHEPPARD SD110

PETROLEUM/SYNTHETIC (50/50) OIL FRONT AXLE

REAR AXLE EQUIPMENT

30000# (13600kg) MERITOR RS-30-185 SINGLE REDUCTION

VENDOR CARRIER

5.63 RATIO

30000# MULTILEAF W/HELPER NO ANTI-SWAY

MERITOR CAM 16.5"x7" P BRAKES

CAST IRON

HALDEX - AUTOMATIC

REAR SPRING BRAKE CHAMBERS 36/36 TYPE

DUST SHIELDS FOR REAR AXLE

FERROUS

75W - 90 (SYNTHETIC LUBRICANT)

MGM TR-T; TAMPER-RESISTANT BRAKE CHAMBERS

DRIVER CONTROLLED INTER WHEEL DIFFERENTIAL LOCK FRT RR AXLE, MANUAL AIR VALVE W/WARNING LIGHT.

4S/4M SYSTEM REAR WHEEL END SENSORS

BENDIX WITHOUT TRACTION CONTROL

FRAME EQUIPMENT/FUEL TANKS

183"

63"

STEEL - 300MM X 90MM X 11.1MM - (11.81" X 3.54" X 0.437")

BUMPER POSITION EXTENDED 20" (SNOW)

STANDARD 2 STEP CAB ACCESS



#294-19



Date 6/11/2019

Quote no. PICK2019000595A595

In Progress

BOC AND INTERMEDIATE(S) STEEL HD BACK-TO-BACK CHANNEL
FURNISH STANDARD STEEL CLOSING REAR CROSSMEMBER
W/O FAST FILL FUEL SYSTEM OPTION
BLACK POLYARMOUR (NO NAME TO APPEAR ON FLAP) (NOT ANTI-SPRAY TYPE)
EXTENDED-SWEPT BACK-STEEL
HOOKS
66 GALLON (250 L) 22" ALUMINUM, SLEEVED D-SHAPED
BASIC FUEL LEVEL SENDER MOUNTED ON L.H TANK
W/O RH FUEL TANK
BRAIDED HOSE
NON-LOCKABLE FUEL TANK CAP
STANDARD FINISH STEPS AND BRIGHT FINISH STRAPS

AIR/BRAKE

WABCO 1200P W/TURBO CUT OFF VALVE, W/COALESCING OIL FILTER, HEATED
MANUAL (PETCOCK) DRAIN VALVES ON ALL TANKS
STEEL
TWO (2) VALVE DUAL BRAKE SYSTEM - TRAILER SUPPLY AND TRACTOR-TRAILER PARK

ELECTRICAL

RH/LH LED WORK LIGHT (STEPS & GROUND) ON BOTH SIDES TRUCK
(5) GROTE LED LAMPS
W/INTERMITTENT FEATURE (AMBIENT NOISE SENSITIVE) 87-112 dB
DASH CTRL/PWR SUPPLY/LOCAL INST PLOW LAMPS W/LEAD FURN@ GRILL W/2W/3W
WEATHER PACK CON
INCANDESCENT TAIL LAMPS
SIX (6) ASSIGNABLE BODYBUILDER DASH SWITCHES (5 ON-OFF, 1 MOMENTARY)
PARK BRAKE AND ENGINE RUNNING ACTIVATED

TRAILER CONNECTIONS

GLAD HAND COUPLINGS - NORTH AMERICAN STD
HAND CONTROL VALVE FOR TRAILER OR REAR SERVICE BRAKES - DUAL FUNCTION
TRAILER AIR BRAKE CONNECTIONS, END OF FRAME
SINGLE 7 PINS STD SAE TYPE, END OF FRAME

PTO

TRANSMISSION PTO SWITCH AND LIGHT WITH WIRING AND PIPING FOR LOCAL
INSTALLATION
1350 SERIES FLANGE (DOES NOT INCLUDE FRONT FRAME EXTENSION)
BODY LINK III W/CAB PASS-THRU

SPECIALTY EQUIPMENT

WITHOUT SPEED LIMIT SIGN RECOGNITION



#294-19



Date 6/11/2019

Quote no. PICK2019000595A695

In Progress

WITHOUT AUXILIARY TRANSMISSION
WITHOUT AUXILIARY TRANSMISSION LOCATION

CAB INTERIOR (A THRU G)

AUX. INCAB PNEUMATIC LINE CLEANOUT
BLEND AIR HVAC W/"ATC" TEMP REGULATION
DASH MTD, INDICATOR BODY/HOIST UP "BODYBUILDER LAMP"
(4) DOME LAMPS - DOOR AND SWITCH ACTIVATED
5LB (ABC RATED/AMEREX) MOUNTED BETWEEN LH SEAT BASE AND DOOR WITH VALVE
AIMED REARWARD
POLYURETHANE FLOOR MAT
EXHAUST PYROMETER GAUGE
U.S. UNITS (PREDOMINANT)

CAB INTERIOR (H THRU R)

DEFAULT: ENGLISH, SPANISH, FRENCH
ALL CHASSIS KEYED AT RANDOM
(2) STORAGE COMPARTMENTS AND NET RETAINERS W/CENTER MOUNTING FOR CB
PROVISIONS
PREMIUM STEREO, AM/FM, CD-PLAYER, MP3, WEATHER BAND, BLUETOOTH
RADIO ANTENNA, CAB MOUNTED BEHIND LH DOOR
PREP KIT FOR MOUNTING ON LT SIDE MIRROR (W/O ANTENNA)
AUTO SHUTOFF FOR RADIO ENTERTAINMENT SYSTEM WHEN VEHICLE IS ENGAGED IN
REVERSE
POWER LEADS (5-WAY BINDING POSTS FOR CB RADIO) IN HEADER CONSOLE
SPEAKER LOCATION, IN DOORS, MIDDLE HIGH SIDE PANEL
CB RADIO MOUNTING REINFORCEMENT IN HEADER CONSOLE
REAR WINDOW (FIXED TYPE)
W/O SLEEPER BOX FURNISH KIT PARALLEL TO INSIDE SURFACE OF RIDER'S SEAT BASE

CAB INTERIOR (S THRU Z)

DRIVER'S SEAT - STEEL GREY VINYL
MACK-AIR, HIGH BACK, 1 CHAMBER AIR LUMBAR
MACK-AIR, HIGH BACK, 1 CHAMBER AIR LUMBAR
PASSENGER'S SEAT - STEEL GREY VINYL
LAP & SHOULDER HEIGHT ADJUSTMENT D-RING SEATBELT RH/LH ORANGE IN COLOR
STANDARD PACKAGE, STEEL GRAY (Package 11A)
KEY TYPE
HEATED TINTED WINDSHIELD, TINTED SIDE AND REAR WINDOW
2 SPOKE URETHANE GRIP, GUNMETAL SPOKES, W/O SWITCHES
SUN VISOR - BOTH SIDES
2-PIECE WINDSHIELD



#294-19



Date 6/11/2019

Quote no. PICK2019000595A595

In Progress

2 SPEED ELECTRIC MOTOR W/INTERMITTENT FEATURE

CAB EXTERIOR

WITH INSPECTION HATCH FOR SNOWPLOW HOOD

PAINTED HOOD LATCHES

(2) MACK RECTANGULAR SINGLE TRUMPET, BRIGHT FINISH ALUMINUM W/SNOW SHIELDS

DUAL TONE

GRILLE PAINTED GRAY

WITH AERO MIRRORS

BULLDOG STYLIZED MIRRORS - LH & RH HEATED & MOTORIZED AND ILLUMINATED W/INTEGRAL CONVEX MIRROR

8" ROUND BF FENDER MTD W/SS BRACKETS & ADJ. ARMS R.H. & L.H. (Same as 15H2001) WITH AERO MIRRORS

RECTANGULAR CONVEX ABOVE RH DOOR WINDOW

AUX. WIN. DOOR ON RIGHT SIDE NON STG WHL POS. DEPEND

REAR CAB SUSPENSION, AIR

BF EXTERIOR CAB GRAB HANDLES, BLACK GRAB HANDLE RH INTERIOR WINDSHIELD POST

SILVER PAINTED W/O GRILLE SURROUND

WHEELS & TIRES

BASIC ROLLING RESISTANCE, POOR FUEL ECONOMY

12R22.5 H GOODYEAR G751 MSA (14780 lbs)

22.5x8.25 ACCURIDE STEEL DISC 10-HOLE HUB PILOTED, HEAVY DUTY, TWO HAND HOLES, (11 1/4"/286mm BC)

TWO FRONT TIRES & WHEELS

OTHER (NON-SPECIFIED), VERY POOR FUEL ECONOMY

12R22.5 H GOODYEAR G622 RSD (27120 lbs) (DRIVE ONLY)

22.5x8.25 ACCURIDE STEEL DISC 10-HOLE HUB PILOTED, TWO HAND HOLES - HEAVY DUTY

W/O REAR DISC WHEEL BRIGHT FINISH

FOUR REAR AXLE TIRES & WHEELS

DRIVE WHEEL STUDS BASIC LENGTH

WHEEL NUT BASIC FINISH, REAR

STANDARD VALVE STEMS AND CAPS

COMMUNICATION SYSTEMS

DISPLAY FEATURES, LIMITED, NO DRIVER ACCESS LEVEL 1

TELEMATICS GATEWAY, 4G/LTE AND WLAN SYSTEM WITH DIAGNOSTIC SERVICES

REMOTE SOFTWARE UPGRADE ENABLED

ENGINE ELECTRONICS



#294-19



Date 6/11/2019

Quote no. PICK2019000595A595

In Progress

WITHOUT ENGINE SOFTWARE SETTINGS
OIL PRESSURE, ENGINE SHUTDOWN
COOLANT TEMP, ENGINE SHUTDOWN
ENGINE PROTECTION (SHUTDOWN)
IDLE CONTROL, 650 RPM
INCREASE 10 MINUTE MAXIMUM TIME
IDLE SHUTDOWN ABS TAMPER CHECK, ENABLED
ENGINE IDLE COOLDOWN, DISABLE
ENGINE IDLE SHUTDOWN, DISABLE
IDLE SHUTDOWN TIME 10 MIN.
38C DEG (100F), WARM UP TEMP DELAY
5 MIN. WARM UP TIME DELAY
ENG IDLE SHUTDOWN TIME OVERRIDDEN IF TORQUE > THAN LIMIT
AMBIENT TEMP MIN TRESHOLD, 16 DEG C, (60 DEG F)
AMBIENT TEMP MAX TRESHOLD, 27 DEG C, (80 DEG F)
ELECTRONIC HAND THROTTLE, MAX ROAD SPEED, 16 KMH (10 MPH)
ELECTRONIC HAND THROTTLE, MAX ENGINE SPEED, 2100 RPM
ELECTRONIC HAND THROTTLE, MIN ENGINE SPEED, 700 RPM

TRANSMISSION ELECTRONICS

223 ON/OFF HIGHWAY, W/O AUTO NEUTRAL, W/O RDCI, AUX FUNCTION RANGE INHIBIT
W/O TRANSMISSION ELECTRONIC SHIFTING PROPERTIES
ECONO ROLL DISABLE mDRIVE (REQUIRED FOR ALL OTHER TRANSMISSIONS)
MACKCELLERATOR DISABLE

VEHICLE ELECTRONICS

DRIVER ID FUNCTION, DISABLED
ENGINE OVERSPEED, ALL CONDITIONS, TIME LOG IF ABOVE 2200 RPM
ENGINE OVERSPEED, FUELED, TIME LOG IF ABOVE 2100 RPM
VEHICLE OVERSPEED, ALL COND, TIME LOG IF ABOVE 75MPH (121KMH)
VEHICLE OVERSPEED, FUELED, TIME LOG IF ABOVE 70MPH (113KMH)
ENGINE IDLE DELAY TO START LOG, 2 MIN
PERIODIC TRIP LOG, DAY 1 OF THE MONTH
DETECTION OF SPEED SENSOR TAMPERING, ENABLE
ENG TORQUE LIMITED TO 50%, IF SPEED SENSOR TAMPER DETECTED
ENGINE HIGH IDLE SPEED IN UPPER GEARS, DISABLED
1950 MAXIMUM ENGINE SPEED AT 0 MPH
105 KM/H ROAD SPEED LIMITER(65 MPH)
105 KM/H PEDAL ROAD SPEED LIMITER (65MPH)
RSL CONTROL TYPE NORMAL



#294-19



Date 6/11/2019

Quote no. PICK2019000595A595

In Progress

DISABLE POWER DIVIDER LOCK OUT (PDLO) ROAD SPEED LIMIT
MAX CRUISE, 105 KPH (65 MPH)
MIN CRUISE, 32 KPH (20 MPH)
ENG BRK ENGAGE IN CRUISE, 3 MPH, ABOVE SET SPEED
CRUISE CONTROL

PTO ELECTRONICS

PTO 1ST, AUTO SET SINGLE SPEED, DISABLE
PTO 2ND, AUTO SET SINGLE SPEED, DISABLE

PAINT

SINGLE COLOR
SOLID PAINT
MACK WHITE; P9188
PAINT - CAB, URETHANE CLEAR COAT
SAME AS FIRST COLOR - CAB
SAME AS FIRST COLOR - HOOD
MACK BLACK (URETHANE)
PAINT BUMPER SAME COLOR AS CHASSIS RUNNING GEAR
PRE-FINISHED POWDER COAT WHITE
PRE-FINISHED POWDER COAT WHITE
WITHOUT OPTIONAL SPOKE WHEEL PAINT
WITHOUT OPTIONAL SPOKE WHEEL PAINT
SAME AS CHASSIS RUNNING GEAR
SAME AS CHASSIS RUNNING GEAR

BASE WARRANTY & PURCHASED COVERAGES

HEAVY DUTY WARRANTY CLASSIFICATION
HEAVY DUTY STANDARD BASE COVERAGE 12 MONTHS/100,000 MILES (161,000 KM)
MACK MP7/MP8 BASE ENGINE COVERAGE 24 MONTHS / 250,000 MILES (402,000KM)
US and CANADA EQUIPPED VEHICLE EMISSION COMPONENTS COVERAGE 60
MONTHS/100,000 MILES (161,000 KM)
ALLISON TRANSMISSIONS (Contact Allison Transmission for standard warranty and extended
coverage data
STANDARD VENDOR NORMAL / HEAVY DUTY COVERAGE 36 MONTHS/350,000 (563,00
KM)
AIR CONDITIONING STANDARD COVERAGE (Sealed System Only) 12 MONTHS UNLIMITED
MILEAGE
STANDARD NORMAL / HEAVY DUTY CHASSIS TOWING 90 DAYS OR 5,000 MILES
STANDARD MACK ENGINE TOWING COVERAGE 24 MONTHS/250,000 MILES (402,000 KM)
24 MONTH - GUARDDOG CONNECT WITH MACK OTA (with ASIST and Mack OneCall))



#294-19



In Progress

Date 6/11/2019

Quote no. PICK2019000595A595

Internal Workshop

prep

one spare tire

\$200 GPS allowance

\$1000 graphics allowance

engine plan 2 w/EATS 5yr 250,000 miles

chassis plan 2 yrs 200,000 miles

allison plan total 5 yrs

meritor 5yr axle carrier plan

pick up warranty work only

battery blanket

icc

body per JC Madigan quote

GBPC

J.C. MADIGAN INC.
450 OLD UNION TURNPIKE
LANCASTER, MA.

SALES DEPT.
TEL. (978)847-2900
FAX (978)847-0068

QUOTE: CITY OF NEWTON CENTRAL MAINT.

TO SHAWN R. @ BALLARD MACK

FROM JOHN DWYER

A) 11FT 7.6/11.2 CUYD REAR DISCHARGE 304 STAINLESS STEEL MATERIAL SPREADER / DUMP BODY HI-WAY MODEL XT-3 TYPE-III INSTALLED ON A TOWN SUPPLIED CHASSIS UNDERCOATED AND ALL NON-STAINLESS ITEMS PAINTED ONE COLOR WITH THE FOLLOWING EQUIPMENT.

- 1) 32" STAINLESS CABSHIELD (MAX. HEIGHT 11')
- 2) AR-400 REMOVEABLE CONVEYOR COVER
- 3) SIDE MOUNTED STAINLESS ACCESS LADDER W/ HANDLE
- 4) 102DBA BACKUP ALARM W/ BUYER'S B95W BU SWITCH
- 4A) 102dba LIFT ALARM W/ AUDIBLE & VISUAL IN-CAB ALERTS
- 5) REAR MOUNTED POLY SPINNER ASSEMBLY
- 6) 20 TON TELESCOPIC HOIST ASSEMBLY / TAILGATE D-RING
- 7) UNDERBODY MOUNTED HI-WAY STAINLESS SPILLSHIELD
- 8) HI-WAY SUPPLIED STAINLESS ANGLED SIDEBORDS
- 9) CRADLE MTD. DRIVER'S ACCESS STEP
- 10) AERO AUTO/ELECTRIC TARPING SYSTEM W/ ALUM. ARMS, SWITCH LOCATED ON DRIVER'S SEAT, AND ASPHALT TARP
- 11) 3/4" PINTLE PLATE W/ 25T PINTLE, D-RINGS, GLAD HANDS, ELECTRIC BRAKE CONTROLS, AND 7-PRONG RV PLUG
- 12) POLY FENDERS, REAR, AND TRANSVERSE REAR AXLE MUDFLAPS
- 13) STAINLESS SANDER LINES PIPED TO THE REAR
- 14) FRONT, SIDE, & REAR RECESSED LED FLASHERS, LED STOP/TAILS, AND REVERSE LIGHTS
- 15) REAR BACKUP CAMERA W/ IN-CAB COLOR DISPLAY
- 16) (2) SPINNER (2) REAR MOUNTED LED WORKLIGHTS
- 17) (2) FENDER MOUNTED STAINLESS PRE-WET TANKS W/ ELECTRIC PRE-WET SYSTEM
- 18) LED TAILLIGHT ASSEMBLIES RECESSED IN THE PINTLE PLATE
- 19) (2) ADDITIONAL 304 STAINLESS COAL DOORS
- 20) (2) (SS) TOOL BOXES TO FILL GAPS ON BOTH SIDES

21) CAB ROOF MTD. WHELEN MINI LIBERTY II

B) 10' FT 39" HIGH STYLE STEEL MOLDBOARD TRIP EDGE SNOW PLOW EVEREST MODEL R120TEL39PH WITH HYDRAULIC REVERSING MODE, CUTTING EDGE, CURB AND WEAR SHOES, CLAMP JAW STYLE QUICK COUPLER, AND GUIDEPOLES.

C) EVEREST CUSTOM POWER TILT PLOW FRAME MODEL PT INSTALLED WITH HOOD MOUNTED ABL LED PLOWLIGHTS, STAINLESS MOUNTS W/ WIONA FLASHERS, AND 30.5" & 21" ON CENTER PIN LOCATIONS

D) TRANSMISSION MOUNTED CENTRAL HYDRAULIC SYSTEM WITH A CHELSEA HOTSHIFT PTO WITH IN-CAB CONTROLS AND VALVE BODY TO CONTROL DUMP, 4-WAY PLOW, AND POWER BEYOND.

- 1) IN-CAB MOUNTED LOW FLUID LEVEL WARNING LIGHT
- 2) CIRUS SPREAD SMART RX CLOSED LOOP GROUND SPEED CONTROLS W/ GPS, WIRELESS DRIVE BY, AND ROADWATCH

PRICE \$111105.00

(96" CA, FRONT FRAME EXT, PTO PROV, PLOW LIGHT PREP, 4 AUX SWITCHES,)

APPROVAL _____ DATE _____

PO# _____ 06/12/2019



Ruthanne Fuller
Mayor

City of Newton, Massachusetts
Office of the Mayor

#285-19

Telephone
(617) 796-1100
Fax
(617) 796-1113
TDD/TTY
(617) 796-1089
Email
rfuller@newtonma.gov

July 12, 2019

Honorable City Council
Newton City Hall
1000 Commonwealth Avenue
Newton Centre, MA 02459

To the Honorable City Councilors:

I am pleased to reappoint Shawn Murphy, of 11 Morrill Street, West Newton as a Constable for the City of Newton. His term of office shall expire September 15, 2022 and his appointment is subject to your confirmation.

Thank you for your attention to this matter.

Warmly,

Ruthanne Fuller
Mayor

RECEIVED
CITY OF NEWTON
2019 JUL 17 AM 11:29
CITY CLERK

Shawn Murphy
11 Morrill Street
Newton, Mass 02465

Objective

To be a positive addition to my community. To serve my community in multiple positions and aspects.

Experience

- 2010-present Newton Fire Dept. Newton, Mass
Assistant Newton Tower Ladder 2
 Manage the daily operations of Ladder 2.
 Station seven inspections officer.
 EMS
- 2008-2010 Newton Fire Dept. Newton, Mass
Assistant Fire Prevention
 Residential plan review, permitting and inspections.
 Summer Camp Inspections/Permitting
 Elder affairs liaison
- 2007-2008 Newton Fire Dept. Newton, Mass
Station 2 Ladder 2
 Station 2 clothing officer.
 Manage daily activities of ladder 1.
 EMS officer of station 2.
- 2000-2007 Newton Fire Dept. Newton, Mass
Private Engine 4 Company
 Driver of engine 4
 Back up driver for C2
 Various duties as private for engine company

Education

- 2001-2005 Middlesex Community College Bedford, Mass
 A.S. in fire protection and equipment
- 2012-2013 Waldorf College Forest City, Iowa
 B.S in Fire Science Administration

Certifications

Mass Certified EMT, Certified Hazardous Materials Technician,
Certified Fire Instructor 1, Certified Fire Officer 1, certified firefighter ½,
Constable City of Newton, Notary public
Numerous Massachusetts Fire Academy classes
Hoisting 1C/2A License, Mass DOT medical card
Spec Rescue Classes (Trench rescue, Structural collapse, Confined space, Rope
Tech/op, Machinery, Auto Ex, Swift water)



The Hanover Insurance Company | 440 Lincoln Street, Worcester, MA 01653
Citizens Insurance Company of America | 645 West Grand River Avenue, Howell, MI 48843
Massachusetts Bay Insurance Company | 440 Lincoln Street, Worcester, MA 01653

PUBLIC OFFICIAL BOND

Bond No.: BOND958397

Know all men by these presents,

That Shawn T. Murphy

as Principal, and The Hanover Insurance Company and/or Massachusetts Bay Insurance Company having its executive office in Worcester, Massachusetts, as Surety, are held and firmly bound unto the

City of Newton in the penal sum of Five Thousand Dollars (\$ 5,000.00) Dollars, for the payment of which, well and truly to be made, we bind ourselves, our heirs, executors, administrators, successors and assigns, jointly and severally, firmly by these presents, the liability of the Surety being limited to said penal sum regardless of the number of years this bond remains in force or is renewed or of the number of premiums that shall be payable or paid.

The condition of this obligation is such, That, Whereas the said Principal was elected or appointed as Constable

Now, therefore, if the Principal shall, during the term three years beginning on the 1st day of July, 2019, well and faithfully perform all and singular the duties incumbent upon it in said office or position, then this obligation shall be void; otherwise it shall be and remain in full force and virtue.

This bond may be extended at the option of the Surety by continuation certificate.

This bond may be terminated and cancelled, at any time, by the Obligee giving written notice to the Surety specifying the effective date of cancellation, or by the Surety mailing written notice to the Obligee and the effective date of such cancellation shall be at the expiration of fifteen days after the date of such notice.

In Witness Whereof, the Principal has hereunto set its hand and seal and the Surety has affixed its corporate seal and caused these presents to be signed by its Attorney-in-Fact this 21st day of June, 2019.

Witness:

Shawn T. Murphy

By: 

THE HANOVER INSURANCE COMPANY

By: _____

MASSACHUSETTS BAY INSURANCE COMPANY

By: 

David Q. Smith, Attorney-in-Fact



THE HANOVER INSURANCE COMPANY
MASSACHUSETTS BAY INSURANCE COMPANY
CITIZENS INSURANCE COMPANY OF AMERICA

POWER OF ATTORNEY

THIS Power of Attorney limits the acts of those named herein, and they have no authority to bind the Company except in the manner and to the extent herein stated.
KNOW ALL PERSONS BY THESE PRESENTS:

That THE HANOVER INSURANCE COMPANY and MASSACHUSETTS BAY INSURANCE COMPANY, both being corporations organized and existing under the laws of the State of New Hampshire, and CITIZENS INSURANCE COMPANY OF AMERICA, a corporation organized and existing under the laws of the State of Michigan, (hereinafter individually and collectively the "Company") does hereby constitute and appoint,

David O. Smith

Of Burgin, Platner & Company, LLC, Quincy, MA each individually, if there be more than one named, as its true and lawful attorney(s)-in-fact to sign, execute, seal, acknowledge and deliver for, and on its behalf, and as its act and deed any place within the United States, any and all surety bonds, recognizances, undertakings, or other surety obligations. The execution of such surety bonds, recognizances, undertakings or surety obligations, in pursuance of these presents, shall be as binding upon the Company as if they had been duly signed by the president and attested by the secretary of the Company, in their own proper persons. Provided however, that this power of attorney limits the acts of those named herein; and they have no authority to bind the Company except in the manner stated and to the extent of any limitation stated below:

Constable

in the amount of: \$5,000.00

That this power is made and executed pursuant to the authority of the following Resolutions passed by the Board of Directors of said Company, and said Resolutions remain in full force and effect:

RESOLVED: That the President or any Vice President, in conjunction with any Vice President, be and they hereby are authorized and empowered to appoint Attorneys-in-fact of the Company, in its name and as it acts, to execute and acknowledge for and on its behalf as surety, any and all bonds, recognizances, contracts of indemnity, waivers of citation and all other writings obligatory in the nature thereof, with power to attach thereto the seal of the Company. Any such writings so executed by such Attorneys-in-fact shall be binding upon the Company as if they had been duly executed and acknowledged by the regularly elected officers of the Company in their own proper persons.

RESOLVED: That any and all Powers of Attorney and Certified Copies of such Powers of Attorney and certification in respect thereto, granted and executed by the President or Vice President in conjunction with any Vice President of the Company, shall be binding on the Company to the same extent as if all signatures therein were manually affixed, even though one or more of any such signatures thereon may be facsimile. (Adopted October 7, 1981 - The Hanover Insurance Company; Adopted April 14, 1982 - Massachusetts Bay Insurance Company; Adopted September 7, 2001 - Citizens Insurance Company of America and affirmed by each Company on March 24, 2014)

IN WITNESS WHEREOF, THE HANOVER INSURANCE COMPANY, MASSACHUSETTS BAY INSURANCE COMPANY and CITIZENS INSURANCE COMPANY OF AMERICA have caused these presents to be sealed with their respective corporate seals, duly attested by two Vice Presidents, this 19th day of July, 2018.

THE HANOVER INSURANCE COMPANY
MASSACHUSETTS BAY INSURANCE COMPANY
CITIZENS INSURANCE COMPANY OF AMERICA

THE HANOVER INSURANCE COMPANY
MASSACHUSETTS BAY INSURANCE COMPANY
CITIZENS INSURANCE COMPANY OF AMERICA

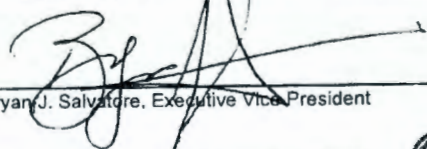

Bryan J. Salvatore, Executive Vice President



James H. Kawiecki, Vice President

THE COMMONWEALTH OF MASSACHUSETTS)
COUNTY OF WORCESTER) ss.

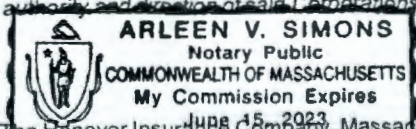

On this 19th day of July, 2018 before me came the above named Executive Vice President and Vice President of The Hanover Insurance Company, Massachusetts Bay Insurance Company and Citizens Insurance Company of America, to me personally known to be the individuals and officers described herein, and acknowledged that the seals affixed to the preceding instrument are the corporate seals of The Hanover Insurance Company, Massachusetts Bay Insurance Company and Citizens Insurance Company of America, respectively, and that the said corporate seals and their signatures as officers were duly affixed and subscribed to said instrument by the authority and direction of said Corporations.

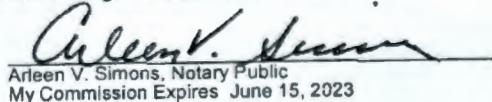

ARLEEN V. SIMONS
Notary Public
COMMONWEALTH OF MASSACHUSETTS
My Commission Expires
JUNE 15, 2023

Arleen V. Simons, Notary Public
My Commission Expires June 15, 2023

I, the undersigned Vice President of The Hanover Insurance Company, Massachusetts Bay Insurance Company and Citizens Insurance Company of America, hereby certify that the above and foregoing is a full, true and correct copy of the Original Power of Attorney issued by said Companies, and do hereby further certify that the said Powers of Attorney are still in force and effect.

GIVEN under my hand and the seals of said Companies, at Worcester, Massachusetts, this 21st day of June 2019

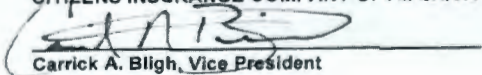
THE HANOVER INSURANCE COMPANY
MASSACHUSETTS BAY INSURANCE COMPANY
CITIZENS INSURANCE COMPANY OF AMERICA

Carrick A. Bligh, Vice President

CERTIFIED COPY