

PLANT SCHEDULE

SYMBOL	BOTANICAL NAME	COMMON NAME	QTY	SIZE	COMMENT
DECIDUOUS TREES					
AR	ACER RUBRUM 'OCTOBER GLORY'	OCTOBER GLORY MAPLE	9	3 - 3 1/2" CAL.	B&B
AS	ACER SACCHARUM 'GREEN MOUNTAIN'	'GREEN MOUNTAIN' SUGAR MAPLE	2	3 - 3 1/2" CAL.	B&B
FG	FAGUS GRANDIFOLIA	AMERICAN BEECH	4	3 - 3 1/2" CAL.	B&B
QP	QUERCUS PALUSTRIS	PIN OAK	11	3 - 3 1/2" CAL.	B&B
QR	QUERCUS RUBRA	RED OAK	11	3 - 3 1/2" CAL.	B&B
ORNAMENTAL TREES					
AC	AMELANCHIER CANADENSIS	SERVICEBERRY	17	8-10' HT.	B&B
BN	BETULA NIGRA	RIVER BIRCH	12	8-10' HT.	B&B
CT	CORNUS ALTERNIFOLIA	PAGODA DOGWOOD	13	8-10' HT.	B&B
ML	MAGNOLIA LOEBNERI 'LEONARD MESSEL'	LEONARD MESSEL MAGNOLIA	23	8-10' HT.	B&B
EVERGREEN TREES					
PS	PINUS STROBUS	WHITE PINE	20	8-10' HT.	
TC	TSUGA CANADENSIS 'ARMISTICE'	ARMISTICE HEMLOCK	3	8-10' HT.	
SHRUBS					
BM	BUXUS MICROPHYLLA 'WINTER GEM'	WINTER GEM BOXWOOD	77	2 1/2 - 3"	
CA	CLETHRA ALNIFOLIA	SUMMERSWEET	51	2 1/2 - 3"	
CS	CORNUS SERICEA 'ARCTIC FIRE'	RED TWIG DOGWOOD	70	2 1/2 - 3"	
EC	ENKIANTHUS CAMPANULATUS	REDVEIN ENKIANTHUS	28	2 1/2 - 3"	
FM	FOTHERGILLA MAJOR 'MOUNT AIRY'	'MOUNT AIRY' FOTHERGILLA	45	2 1/2 - 3"	
IG	ILEX GLABRA 'COMPACT'	COMPACT INKBERRY	58	2 1/2 - 3"	
KL	KALMA LATIFOLIA	MOUNTAIN LAUREL	14	2 1/2 - 3"	
LB	LINDERA BENZON	NORTHERN SPICEBUSH	15	2 1/2 - 3"	
RC	RHOODOENDRON 'CATAMBIENSE ALBUM'	CATAMBA RHOODOENDRON	19	5' HT.	
RB	RHOODOENDRON 'BOULE DE NEIGE'	BOULE DE NEIGE RHOODOENDRON	24	5' HT.	
RJ	RHOODOENDRON 'JANET BLAIR'	JANET BLAIR RHOODOENDRON	24	5' HT.	
PERENNIALS / GROUNDCOVERS / GRASSES					
CP	CAREX PENNSYLVANICA	PENNSYLVANIA SEDGE	554	1 GAL	
CB	CAREX 'BLUE ZINGER'	BLUE ZINGER SEDGE	104	1 GAL	
DC	DESCHAMPSIA CESPITOSA	TUFTED HAIR GRASS	93	1 GAL	
LM	LIRIOPE MUSCARI	LIRIOPE	418	1 GAL	
MS	MISCANTHUS SINENSIS	SILVER GRASS	114	3 GAL	
PV	PANICUM VIRGATUM 'CHEYENNE SKY'	SWITCH GRASS	331	3 GAL	
OR	OSMUNDA REGALIS	ROYAL FERN	6	1 GAL	
SEED MIXES					
1. GENERAL LAWN MIX					
2. NEW ENGLAND SHOWY WILDFLOWER MIX					
3. NEW ENGLAND CONSERVATION / WILDLIFE MIX					
IRRIGATION					
ALL AREAS INCLUDING ROOF DECKS TO RECEIVE IRRIGATION; REFER TO DESIGN BUILD SPECIFICATION					

LEGEND

- DECIDUOUS TREE
- ORNAMENTAL TREE
- EVERGREEN TREE
- DECIDUOUS SHRUBS
- EVERGREEN SHRUBS
- GROUNDCOVER AND/OR PERENNIAL MASSING
- GENERAL LAWN MIX
- WILDFLOWER & CONSERVATION MIX AREAS

NO.	DATE	REVISION
01	05/05/2021	SPECIAL PERMIT
02	05/25/2022	REVISED SPECIAL PERMIT

Stantec

Stantec Planning and Landscape Architecture P.L.
 226 Causeway Street 6th Floor
 Boston MA
 02114-2155
 Tel. (617) 523-8103
 Fax. (617) 523-4333
 www.stantec.com

PERKINS EASTMAN

1100 Liberty Avenue
 Pittsburgh, PA 15222
 T +1 412 456 9900
 F +1 412 456 9900

Owner:
2 LIFE COMMUNITIES
 30 Wallingford Road
 Brighton, MA 02135

Construction Manager:
DELLBROOK
 One Adams Place
 859 Willard Street
 Quincy, MA 02169

Civil / Site:
STANTEC
 226 Causeway Street, 6th Floor
 Boston, MA 02114

Structural:
VEITAS & VEITAS ENGINEERS, INC
 639 Granite Street
 Braintree, MA 02184

MEP consultant:
PETERSEN ENGINEERING, INC
 127 Parrott Avenue
 Portsmouth, NH 03801

PROJECT TITLE:
2LIFE - OPUS

677 WINCHESTER STREET
 NEWTON, MA 02459

PROJECT No: 66571
 DRAWING TITLE:
PLANTING PLAN

SCALE: AS NOTED
LU-L501
 ZONING REVIEW
 3/03/2021

U:\Projects\2021\2021-03-03 LU-L501\Drawing\LU-L501.dwg, 3/3/2021 10:00:00 AM, P:\Users\jgibson\OneDrive\Documents\LU-L501.dwg



Stantec Planning and Landscape Architecture P.C.
 226 Causeway Street 6th Floor
 Boston MA
 02114-2155
 Tel. (617) 523-8103
 Fax. (617) 523-4333
 www.stantec.com



Owner:
2 LIFE COMMUNITIES
 30 Wallingford Road
 Brighton, MA 02135
 Construction Manager:
DELLBROOK
 One Adams Place
 859 Willard Street
 Quincy, MA 02169
 Civil / Site:
STANTEC
 226 Causeway Street, 6th Floor
 Boston, MA 02114

Structural:
VEITAS & VEITAS ENGINEERS, INC
 633 Granite Street
 Braintree, MA 02184
 MEP consultant:
PETERSEN ENGINEERING, INC
 127 Parrott Avenue
 Portsmouth, NH 03801

PROJECT TITLE:

2LIFE - OPUS

677 WINCHESTER STREET
 NEWTON, MA 02459

PROJECT NO: 66571

DRAWING TITLE:
SITE DETAILS

SCALE:

LU-L601

ZONING REVIEW

3/03/2021

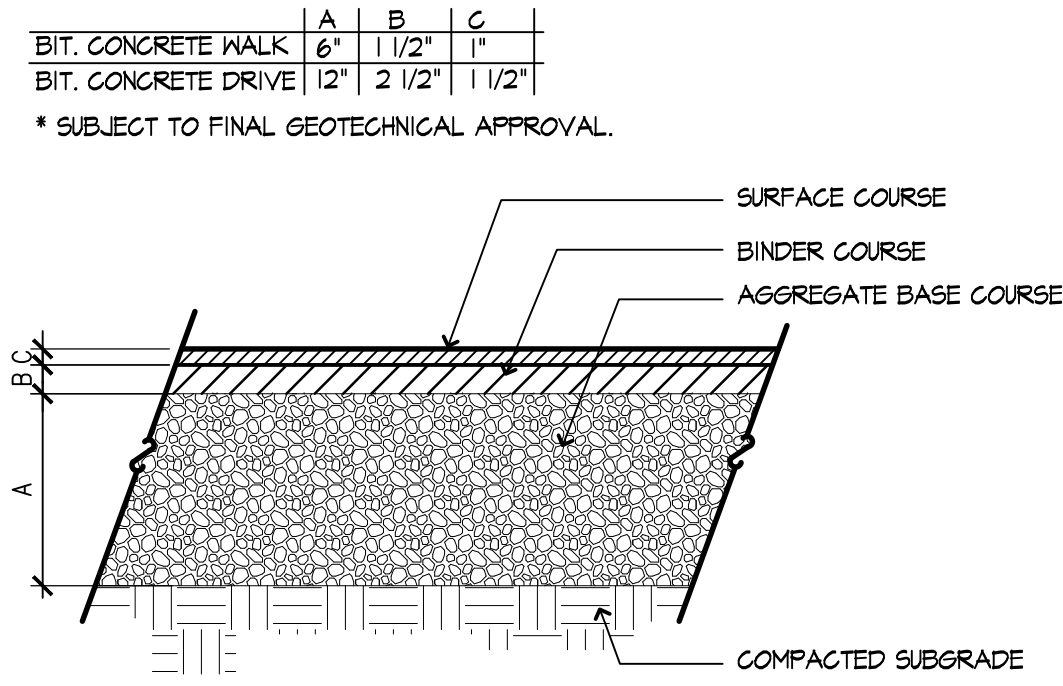

1 BITUMINOUS CONCRETE PAVING
 SCALE: 1" = 1'-0"

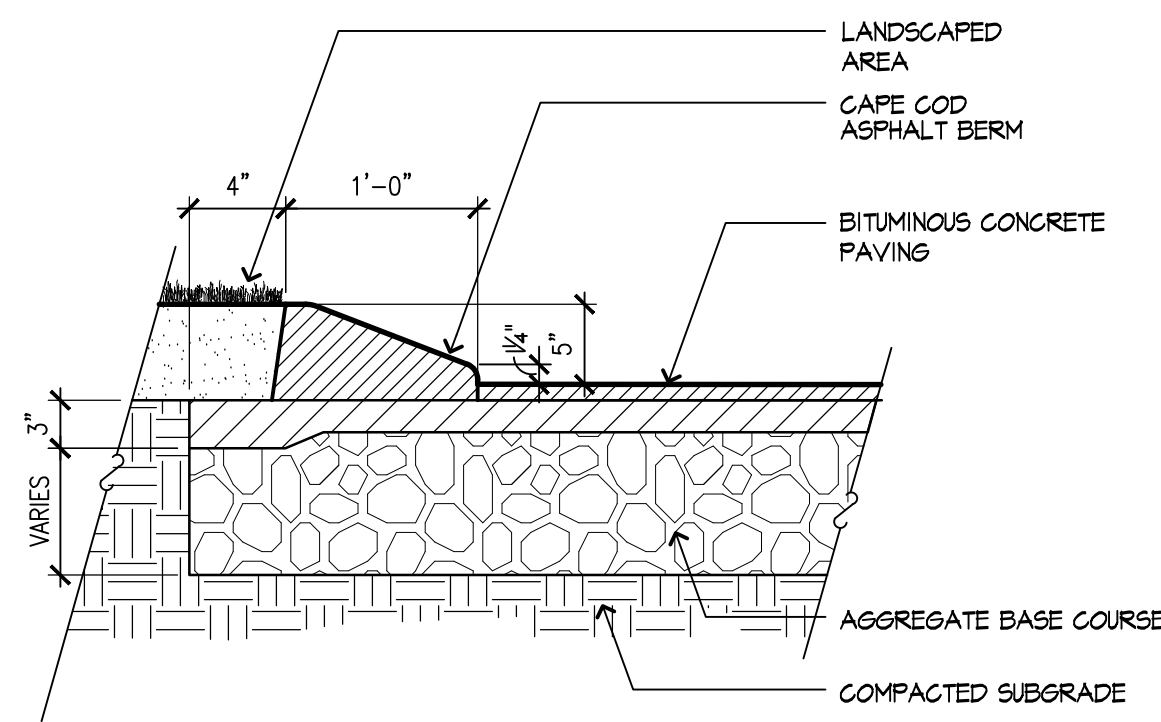

2 CAPE COD BERM CURB
 SCALE: 1" = 1'-0"

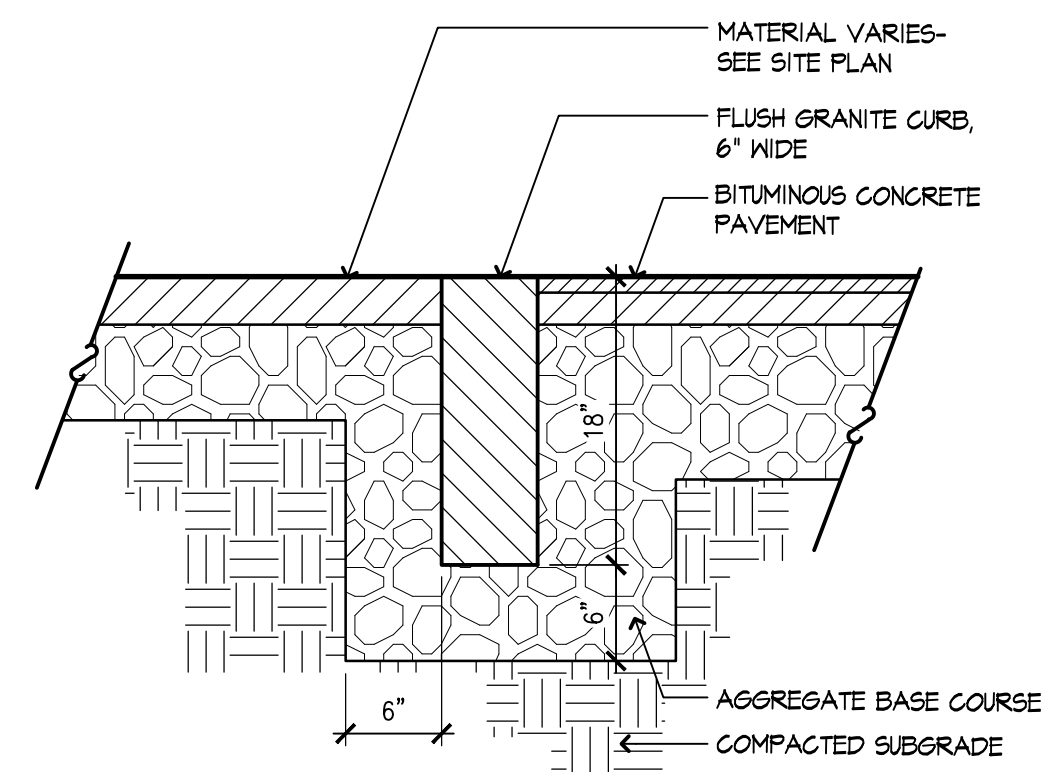

3 FLUSH GRANITE CURB
 SCALE: 1" = 1'-0"

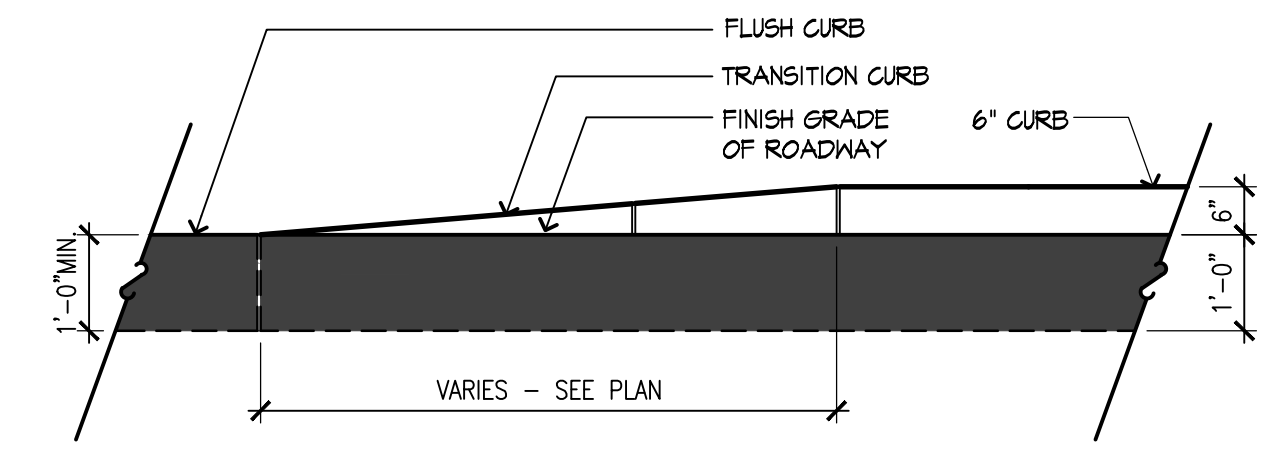

4 GRANITE TRANSITION CURB
 SCALE: 1/2" = 1'-0"

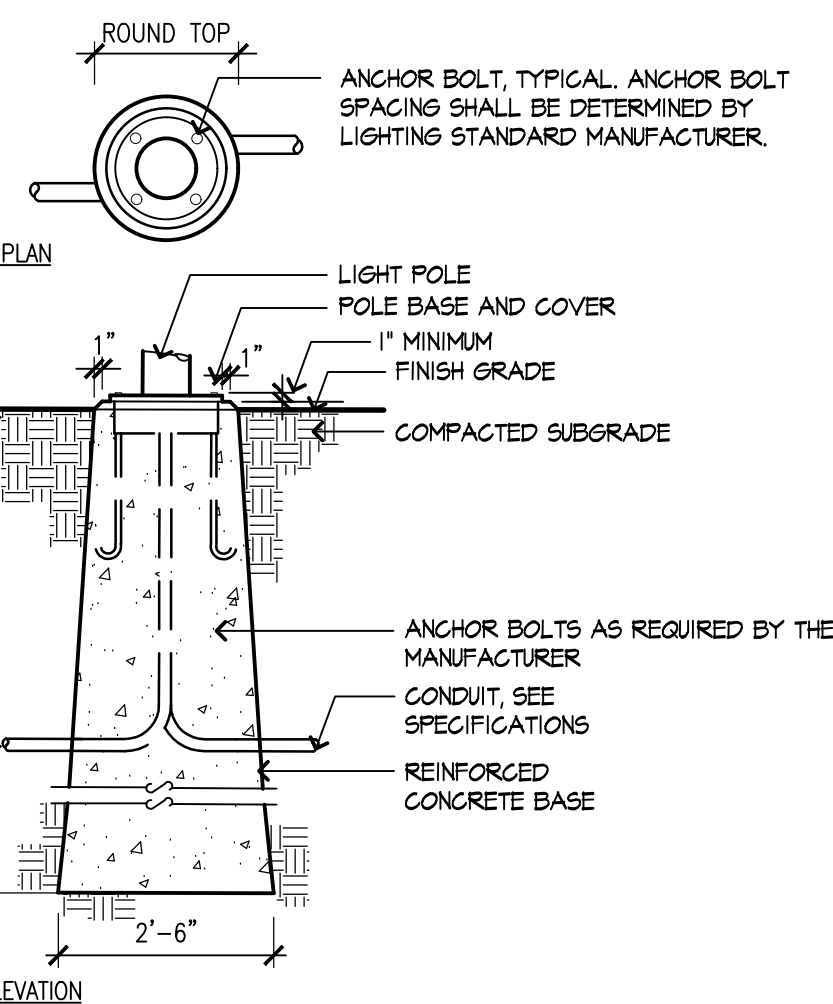

5 LIGHT POLE BASE - FLUSH
 SCALE: 1/2" = 1'-0"

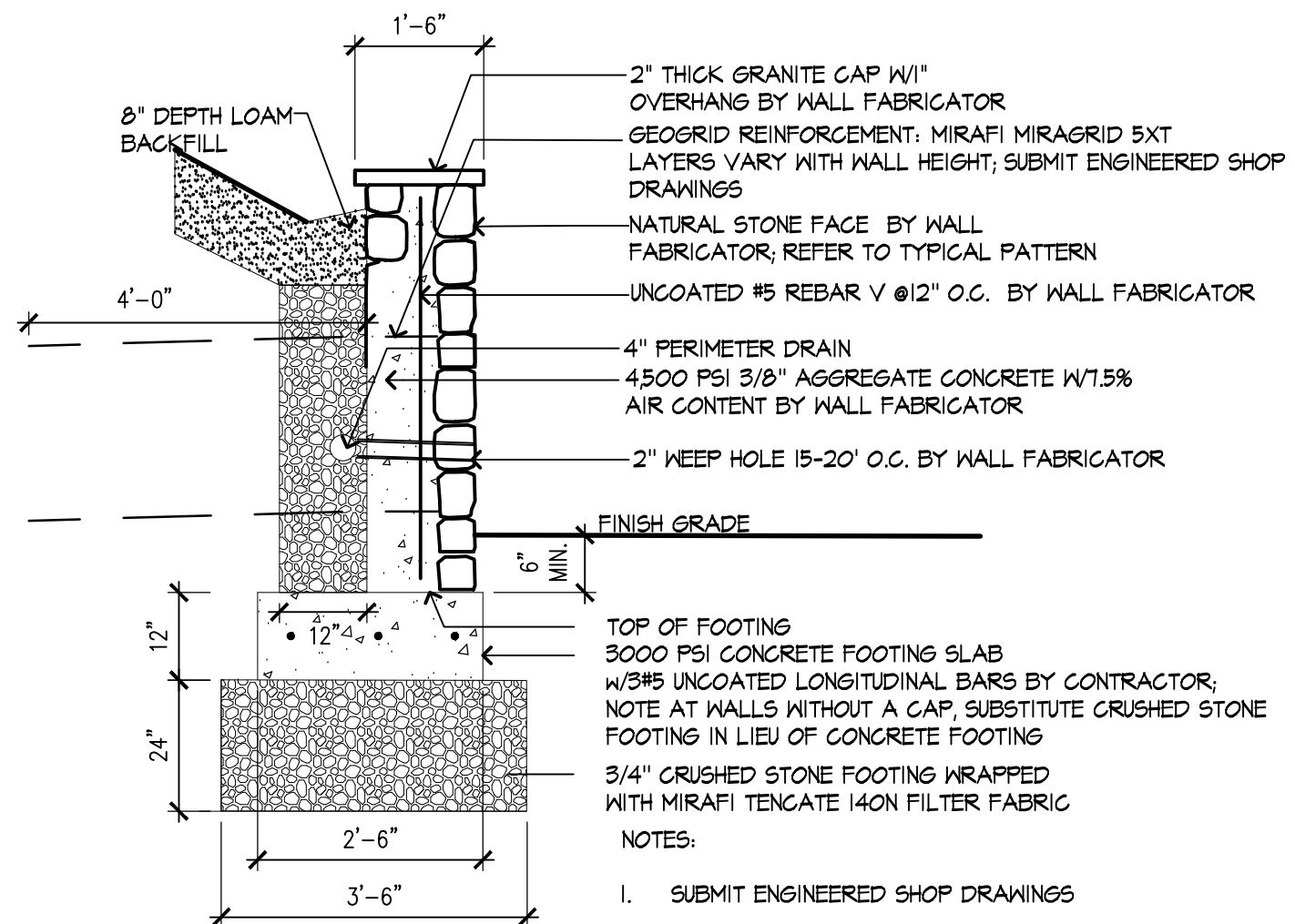

6 STONE SITE WALL
 SCALE: 1/2" = 1'-0"

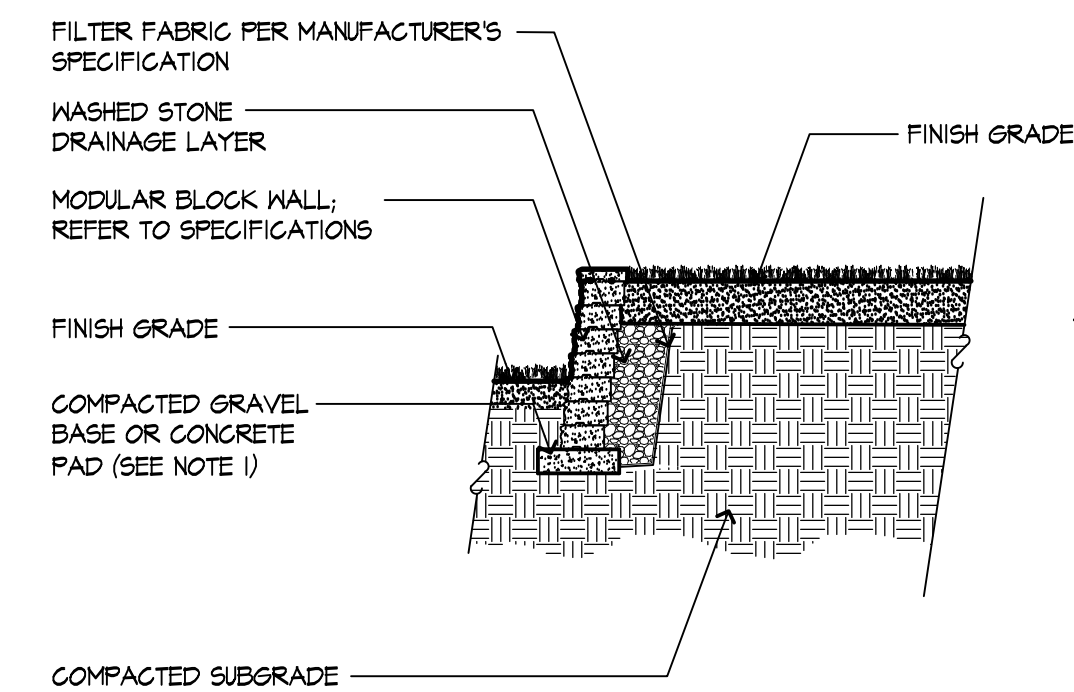

7 MODULAR BLOCK RETAINING WALL
 SCALE: 1/4" = 1'-0"

- NOTES:
- THIS ILLUSTRATION IS PROVIDED TO ILLUSTRATE THE GENERAL ARRANGEMENT OF A SEGMENTAL BLOCK RETAINING WALL STRUCTURE. THIS DRAWING MUST BE USED IN CONJUNCTION WITH THE RELATED DETAIL DRAWINGS AND SPECIFICATIONS FOR PROPER DESIGN AND CONSTRUCTION, AS PREPARED BY A MASSACHUSETTS REGISTERED STRUCTURAL ENGINEER AS SUBMITTED BY THE CONTRACTOR.
 - STRUCTURES SUCH AS HANDRAILS, GUARDRAILS, FENCES, TERRACES, AND SITE CONDITIONS SUCH AS WATER APPLICATIONS, DRAINAGE, AND SOIL CONDITIONS, ADDITIONAL LIVE AND DEAD LOADS, ETC., HAVE SIGNIFICANT EFFECTS ON THE WALL DESIGN. CONTRACTOR SHALL SUBMIT SHOP DRAWINGS FOR SUCH SPECIFIC CONDITIONS AS PER NOTE 1.
 - THICKNESS OF WASHED STONE DRAINAGE LAYER, SIZE OF COMPACTED GRAVEL BASE SHALL BE DETERMINED BY FINAL DESIGN OF WALLS AS PER NOTE 1.

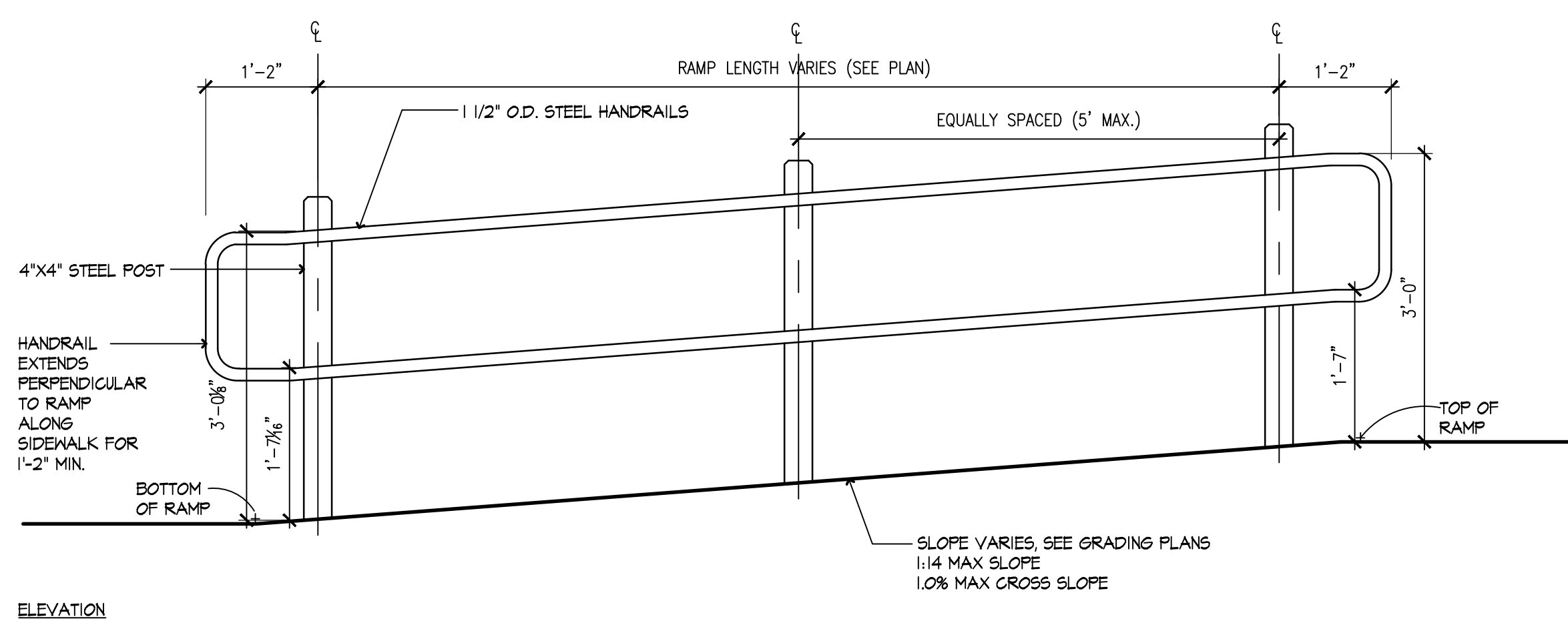

8 RAMP AND HANRAILS
 SCALE: 1/2" = 1'-0"

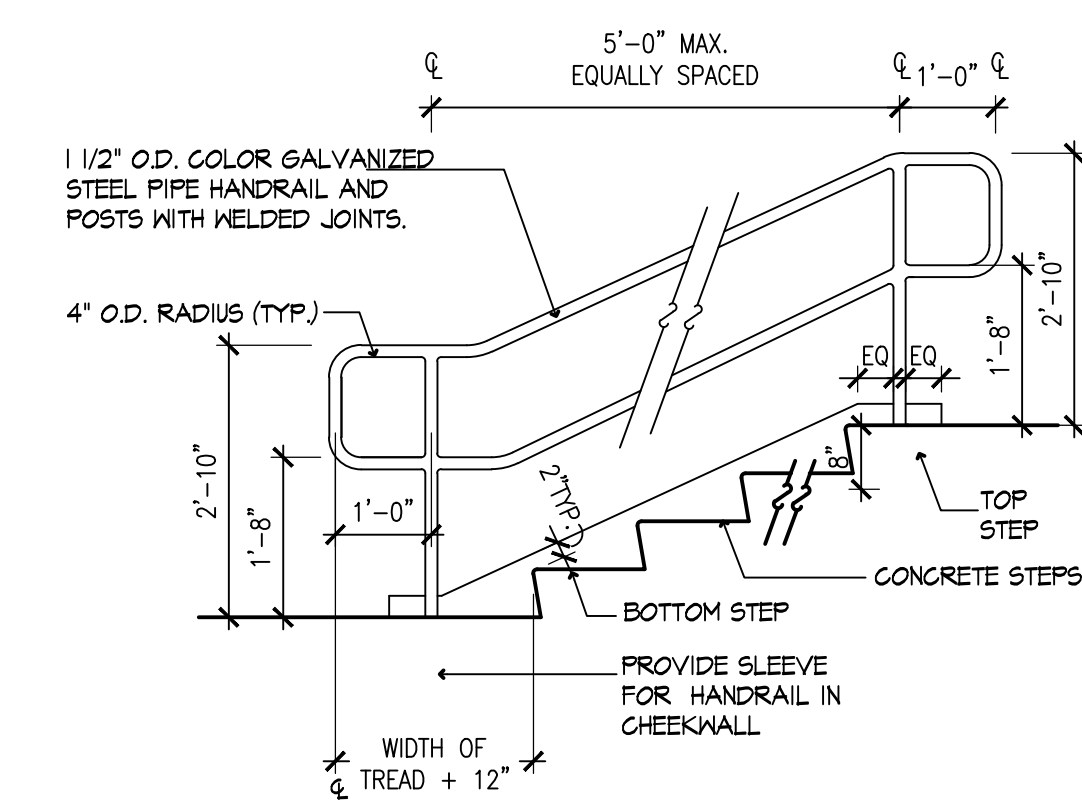

9 CONCRETE STAIRS AND HANRAILS
 SCALE: 1/2" = 1'-0"

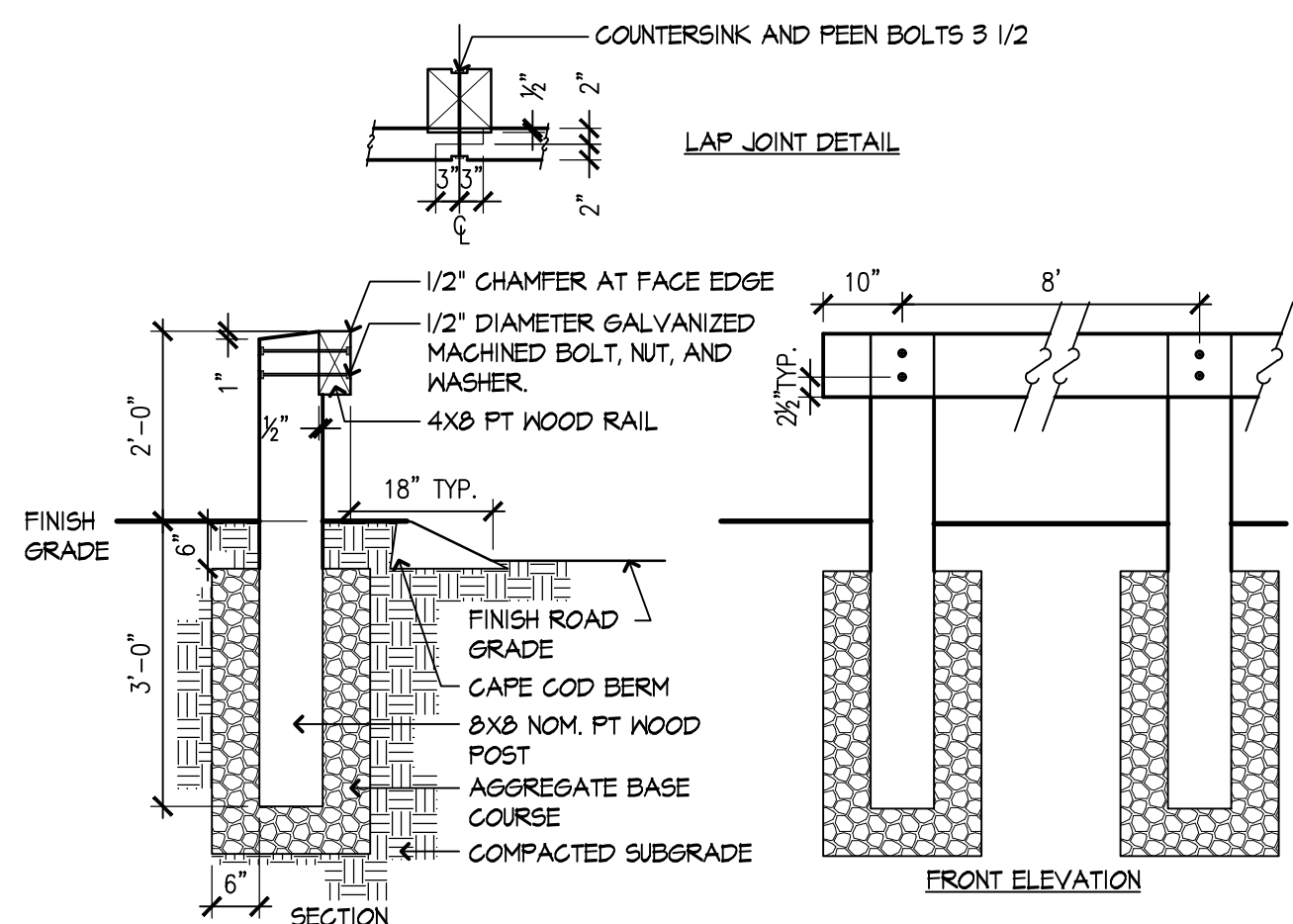

10 WOOD VEHICULAR GUARDRAIL
 SCALE: 1-1/2" = 1'-0"

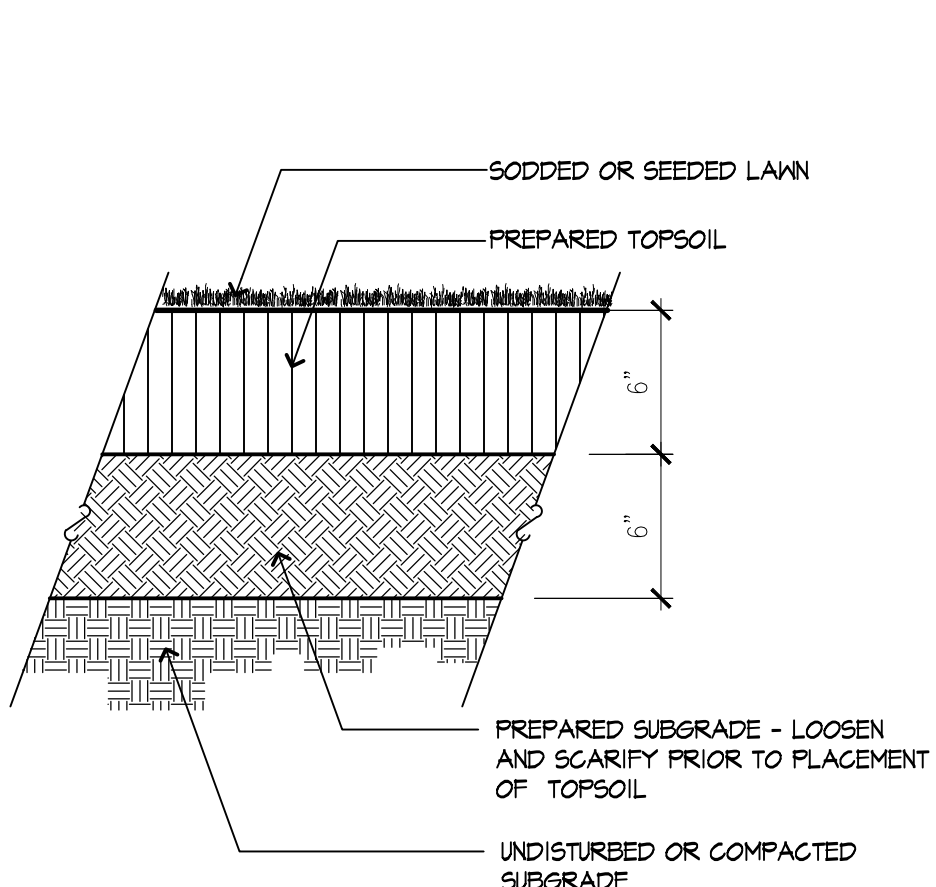

11 LOAM AND SEED
 SCALE: 1/2" = 1'-0"

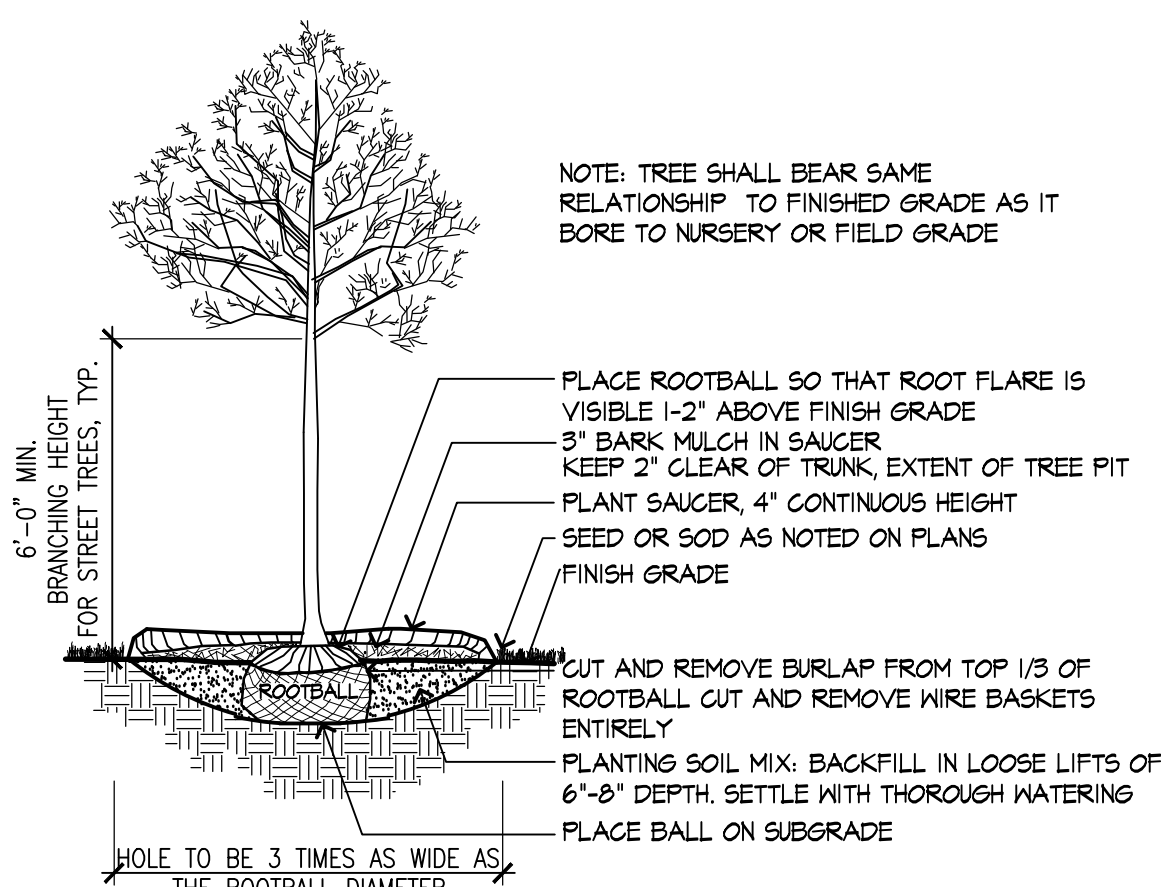

13 DECIDUOUS TREE PLANTING
 SCALE: 1/2" = 1'-0"

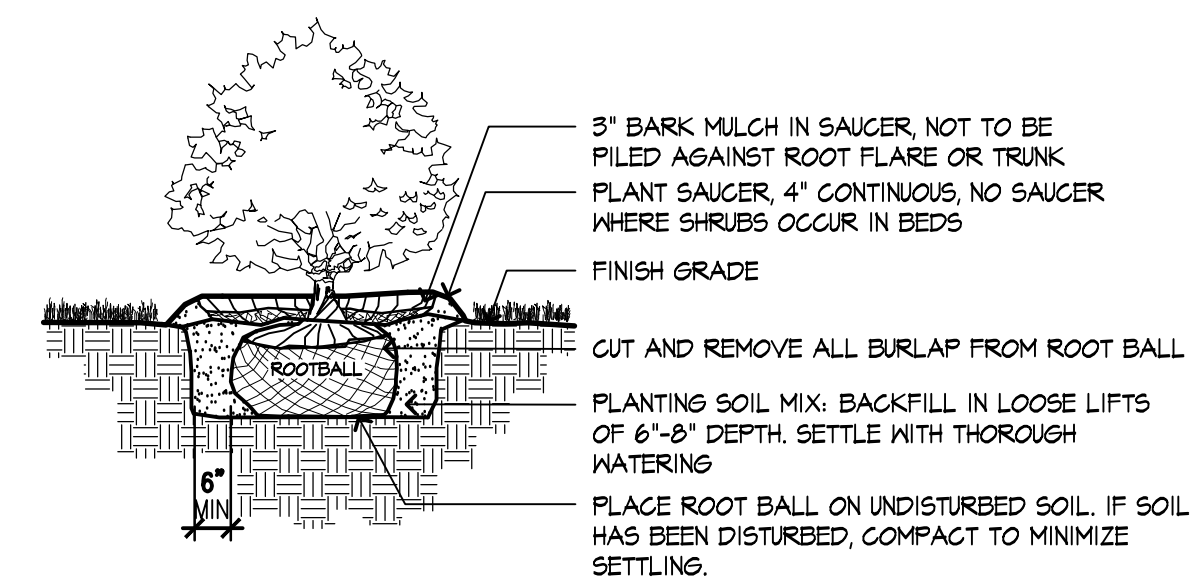

13 SHRUB PLANTING
 SCALE: 1/2" = 1'-0"