



City of Newton, Massachusetts
Department of Planning and Development
1000 Commonwealth Avenue Newton, Massachusetts 02459
617-796-1120

Ruthanne Fuller
Mayor

Barney S. Heath
Director

PUBLIC HEARING MEMORANDUM

DATE: August 22, 2024

TO: City Council

FROM: Barney S. Heath, Director of Planning and Development
Katie Whewell, Chief Planner for Current Planning
Alyssa Sandoval, Deputy Chief Planner for Current Planning

SUBJECT: **Petition #299-24** Request to amend Special Permit #240-23 to extend a nonconforming side setback, at 290 Watertown Street, Ward 1, Newton, on land known as Section 11 Block 14 Lot 03, containing approximately 11,473 sq. ft. of land in a district zoned BUSINESS 1. Ref: 7.3.3, 4.4.1, 4.1.2.B.3, 4.1.3, 5.1.4, 5.1.13 of Chapter 30 of the City of Newton Rev Zoning Ord, 2017.

The purpose of this memorandum is to provide the City Council and the public with technical information and planning analysis conducted by the Planning Department. The Planning Department's intention is to provide a balanced review of the proposed project based on information it has at the time of the public hearing. Additional information about the project may be presented at or after the public hearing for consideration at a subsequent working session by the Land Use Committee of the City Council.



290 Watertown Street

Project Description

Background

A special permit was granted for the development with four residential units in a 3-story, 10,735-square-foot building in 2023. The petitioner now seeks to amend the special permit to modify the front setback to move the building slightly closer to the street compared to the previously approved site plan. The reduced front yard setback helps to increase the width of the gap between the middle Units 2 and 3 created by the green roof/carport from 35.3 feet to 38.3 feet. The petitioner has stated that this change was made to accommodate the request of an abutter. There are no other changes that affect zoning relief as a result of the modified site plan. Planning provides the planning memorandum, Compiled Planning Memorandum, November 9, 2023 (Attachment C), for further background on the original project.

Analysis

The original special permit (#240-23) was granted to demolish the existing nonconforming two-family dwelling and garage and construct four residential units in a 3-story, 10,735-square-foot building with a centrally located, single level covered carport with green roof. The proposed amendment does not increase the size of the development in height or square footage but reduces the front setback of the proposed development.

The Land Use Committee previously approved the project in 2023 and Planning notes the changes from the previously approved plan are minor. The reduced front yard setback and increased width of the carport/green roof are the main changes since the original special permit was granted. Under the current proposed site plan, the front setback has been slightly reduced from the special permit approved site plan under #240-39 (from 8 feet to 7.3 feet) but still just meets the required setback of at least 7.2 feet. The proposed front setback corrects a non-conforming existing front setback of 6.7 feet. The proposed site plan also slightly enlarges the side yard setbacks compared to the existing house although the side setback along the western property line is still non-conforming at 13.5 feet.

Planning does not have specific issues with the proposed amendment as the changes are minor from the originally approved site plan. The proposed residential use is within a mixed-use neighborhood. The small-scaled design of the building facing Watertown Street has the appearance of a single-family home and helps to reduce the overall visual mass of the 4-unit development. Planning notes that the slightly reduced setback from 8 feet to 7.3 feet still meets the requirements of the Newton Zoning Ordinance and provides a larger setback than the original home and corrects a preexisting nonconformity.

I. Zoning Relief Requested:

Zoning Relief Required		
<i>Ordinance</i>	<i>Requested Relief</i>	<i>Action Required</i>
	To amend Special Permit #240-23	
§4.1.3 §7.8.2.C.2	To alter and extend a nonconforming side setback	S.P. per §7.3.3

II.

For more details around the zoning analysis please refer to **Attachment A**.

III. Criteria for Consideration per §7.3.3 and/or §5.1.13:

- The site is an appropriate location for the amendment to Special Permit #240-23 and the proposed 4-unit, three-story residential development with ground level parking. (§7.3.3.1)
- The amendment to Special Permit #240-23 will not adversely affect the neighborhood. (§7.3.3.2)
- There will not be a nuisance or serious hazard to vehicles or pedestrians as a result of the amendment to Special Permit #240-23. (§7.3.3.3)
- Access to the site is appropriate for the types and numbers of vehicles involved. (§7.3.3.4)

IV. Project Proposal and Site Characteristics

A. Site

The site consists of one long, narrow 11,473 square-foot parcel at 290 Watertown Street in the BU-1 zone. The property is improved with a two-story, 29-foot high, two-unit multi-family dwelling.

The lot slopes down gradually from the front to the rear of the property about five feet in total. Vehicular access to the property is provided by a curb cut and 12.1-foot-wide driveway located along the front, right side of the property, which leads to a detached two-car garage. In the area between the house and garage is an asphalt driveway area and small patio area as well as concrete debris. Behind the garage and patio at the rear of the lot is an extensive undeveloped rear yard area which includes two trees and grass.

V. Project Description and Analysis

A. Land Use

The current use of the site is two-family residential. The previous special permit #240-23 approved the construction of a four-unit multifamily residential use.

B. Site Design

Special Permit #240-23 allowed a four-unit, 10,735 square-foot residential development with a combination of ground level garages, dedicated patios, and outdoor space. The residential development also includes a central carport for two parking stalls covered with a green roof patio garden.

The prior special permit approved a retaining wall along the side and rear lot lines but does not exceed four feet in height (approximately 3.5 feet in height at the highest point). There is an existing retaining wall along the side western property line of approximately 3 to 4 feet in height. The grade will be raised as result of the site work according to the site plan particularly to the rear of the lot where the grade will be raised by approximately four feet. As such, the height of the proposed building at 31.97 feet will appear by abutters at least 4 feet taller towards the rear of the lot compared to the existing site. The City Council recently revised the height measurement in the Zoning Ordinance to be taken from “original grade” when raising the grade. Height is still measured from “proposed grade” if lowering the overall grade. The effective date of the new ordinance will be January 1, 2025 so does not currently affect the approved special permit and would not affect the current petition if approved before January 1, 2025.

The previously granted special permit was required to expand the ground floor residential use with above residential use in a BU-1 district. The previous special permit also granted relief for the height and the number of stories.

Under the current proposed site plan, the front setback is slightly reduced from the special permit approved site plan under #240-23 (from 8 feet to 7.3 feet) but still just meets the required setback of at least 7.2 feet. The proposed setback corrects a non-conforming existing front setback of 6.7 feet. The proposed site plan also slightly enlarges the side yard setbacks compared to the existing house although the side setback along the western property line is still non-conforming at 13.5 feet.

The units are a mix of three and four-bedrooms, and range in size from 2,515 square feet to 2,766 square feet. The proposed front elevation on Watertown Street appears to be in keeping with neighboring properties and presents as a single-family dwelling. The front elevation features architectural elements, such as a front door entry with porch and dormer, which resemble a single-family.

Proposed Front Elevation of Unit 1 (Watertown Street)



Proposed Rear Elevation of Unit 4



Proposed Right Elevation (Units 1 & 2 only)



Proposed Right Elevation (Units 3 & 4 only)



Proposed Left Elevation (Units 1 & 2)



Proposed Left Elevation (Units 3 & 4)



C. Parking and Circulation

Per section 5.1.4 of the NZO, two parking stalls are required per each dwelling unit. As designed, the residential development will have sufficient parking and meets the parking requirements of the Newton Zoning Ordinance.

VI. PETITIONER'S RESPONSIBILITIES

This petition is considered complete.

ATTACHMENTS:

- Attachment A:** Zoning Review Memorandum
- Attachment B:** DRAFT Council Order
- Attachment C:** Compiled Planning Memorandum, November 9, 2023



Ruthanne Fuller
Mayor

City of Newton, Massachusetts
Department of Planning and Development
1000 Commonwealth Avenue Newton, Massachusetts 02459

Telephone
(617) 796-1120
Telefax
(617) 796-1142
TDD/TTY
(617) 796-1089
www.newtonma.gov

Barney S. Heath
Director

ZONING REVIEW MEMORANDUM

Date: August 20, 2024

To: Anthony Ciccarillo, Commissioner of Inspectional Services

From: Jane Santosuosso, Chief Zoning Code Official
Katie Whewell, Chief Planner for Current Planning

Cc: Laurance Lee, Attorney
290 Watertown St LLC, Applicant
Barney S. Heath, Director of Planning and Development
Jonah Temple, Deputy City Solicitor

RE: Request to amend Special Permit #240-23

Applicant: 290 Watertown St LLC	
Site: 290 Watertown Street	SBL: 11014 0003
Zoning: BU1	Lot Area: 11,473 square feet
Current use: Two-family dwelling	Proposed use: Five residential dwelling units

BACKGROUND:

The property at 290 Watertown Street consists of 11,473 square feet and is improved with a nonconforming two-family dwelling constructed circa 1880 and a detached garage in the BU1 zoning district. Special Permit #240-23 was granted to construct four residential dwelling units in one building. The petitioner now seeks to amend the special permit to allow for a greater gap between the upper floors of the building between Units 2 and 3, and to convert three garage stalls to a carports.

The following review is based on plans and materials submitted to date as noted below.

- Zoning Review Application, prepared by Laurance Lee, attorney, submitted 5/7/2024
- Civil Plan I (Approved Site Plan), signed and stamped by Christopher C. Charlton, surveyor, and Edmond Spruhan, engineer, dated 7/25/2023
- Civil Plan I Layout and Topography, signed and stamped by Christopher C. Charlton, surveyor and Edmond T. Spruhan, engineer, dated 3/16/2023, revised 7/25/2023, revised 10/25/2023, 11/2/2023, 2/8/2024, 3/25/2024, 4/18/2024, 5/6/2024, revised 7/
- Floor plans and elevations, prepared by MGD, architect, dated 2/26/2023, revised 3/19/2024

ADMINISTRATIVE DETERMINATIONS:

1. The petitioner seeks to amend the approved Special Permit #240-23 to move Unit 1 closer to the street, reducing the approved front setback and increasing the width of the gap between Units 2 and 3 created by the green roof from 35.3 feet to 38.3 feet at the request of an abutter. Additionally, one garage bay of each of the two-car garages associated with Units 1, 2 and 3 will be replaced with carports, maintaining the green roof above. Only the portion of the building associated with Unit 1 will see any changes to setbacks.
2. The Special Permit #240-23 approved plans included an extension of the existing nonconforming side setback. The previously approved proposed construction alters the prior existing nonconforming easterly side setback by and running along the lot line by extending back towards the rear, but lessens the nonconformity from 13.3 feet to 13.5 feet, where 15 feet is required per section 4.1.3. The petitioner seeks to memorialize the side setback relief so as to be consistent with the previously approved plans.

BU1 Zone	Required	Existing	Approved	Proposed
Lot Size	10,000 square feet	11,473 square feet	No change	No change
Setbacks				
• Front	7.2 feet (average)	6.8 feet	8 feet	7.3 feet
• Side	15 feet (1/2 Bldg Height)	13.3 feet	13.5 feet	No change**
• Side	15 feet (1/2 Bldg Height)	12.1 feet	17.2 feet	No change*
• Rear	15 feet (1/2 Bldg Height)	138.6 feet	16.2 feet	No change *
Building Height	24 feet (36 feet by SP)	29 feet	31.97 feet*	No change*
Max Number of Stories	2.5 (3 by SP)	2.5	3*	No change*
Lot Area Per Unit	1,200 square feet	5,737 square feet	2,868 square feet	No change*
FAR	1.5 (3 stories)	Not available	.95	.92

*No change from the approved plans

**There are no changes from the previously approved plans, however relief is required for the extension of the nonconforming setback

See “Zoning Relief Summary” below:

Zoning Relief Required		
<i>Ordinance</i>	<i>Requested Relief</i>	<i>Action Required</i>
	To amend Special Permit #240-23	
§4.1.3 §7.8.2.C.2	To alter and extend a nonconforming side setback	S.P. per §7.3.3

CITY OF NEWTON

IN CITY COUNCIL

ORDERED:

That the City Council, finding that the public convenience and welfare will be substantially served by its action, that the use of the site will be in harmony with the conditions, safeguards and limitations set forth in the Zoning Ordinance, and that said action will be without substantial detriment to the public good, and without substantially derogating from the intent or purpose of the Zoning Ordinance, grants approval of the following SPECIAL PERMIT/SITE PLAN APPROVAL to amend Special Permit #240-23 to reduce the approved front setback and to alter and extend a nonconforming side setback in accordance with the recommendation of the Land Use Committee and the reasons given by the Committee therefore, through its Chair, Andrea Kelley:

1. The specific site is an appropriate location for the proposed four-unit residential development as designed, which includes ground level residential and three stories in a BU-1 district. The scale and design of the proposed development is appropriate for the location, and surrounding neighborhood, which has a mix of businesses and residences, including restaurants, stores, personal service businesses, multi-family residential developments, and two-story homes. While containing four units, the project presents as a single-family home from the front elevation, maintaining the overall presence from the street as the existing single family use. (§7.3.3.C.1)
2. The amendment to Special Permit #240-23 is not substantially more detrimental to the neighborhood because the nonconforming side setback of 13.5 feet will be a slight improvement to the side setback of the existing condition of 13.3 feet. (§7.8.2.C.2)
3. The proposed four units in a three-story building will not adversely affect the neighborhood because the maximum height of the building is similar to what currently exists on the site. The building includes varying heights and a second story green roof, which helps to reduce the overall visual mass of the structure and provides visual relief for neighboring properties. The amendment to Special Permit #240-23 will provide a visual improvement to neighbors because it widens the single-story carport covered by a green roof between the two main residential structures adjacent to neighbors (§7.3.3.C.2)
4. The amendment to Special Permit #240-23 and proposed four unit-development will not create a nuisance or serious hazard to vehicles or pedestrians because the driveway width is only 13.1 feet wide, creating a narrower crossing distance for pedestrians. The driveway is also being maintained in the same location as the existing conditions of the site and is limited to one way traffic. (§7.3.3.C.3)

5. Access to the site over streets is appropriate for the types and numbers of vehicles involved because the driveway location is being maintained, the crossing distance for pedestrians is 13.1 feet and limited to one way traffic, and all required parking is accommodated on site. The amendment to Special Permit #240-23 will correct the existing nonconforming front setback of the existing house and provides better visibility for motorists exiting the driveway onto Watertown Street (§7.3.3.C.4)

PETITION NUMBER: #299-24

PETITIONER: 290 Watertown Street LLC

LOCATION: 290 Watertown Street, on land known as Section 11 Block 14 Lot 3, containing approximately 11,473 sq. ft.

OWNER: 290 Watertown Street LLC

ADDRESS OF OWNER: 290 Watertown Street LLC
20 Holly Street
Salem, MA 01970

TO BE USED FOR: Four dwelling units

EXPLANATORY NOTE: Special permit per §4.4.1 to allow ground level residential use, to allow a three-story structure (§4.1.2.B.3), to allow buildings greater than 24 feet in height (§4.1.3), and to alter and extend a nonconforming side setback (§4.1.3, §7.8.2.C.2)

ZONING: Business Use 1

The prior Special Permit/Site Plan Approval governing this property is #240-23. This Special Permit/Site Plan Approval supersedes #240-23. As such, #240-23 is null and void.

Approved, subject to the following conditions:

1. All buildings, parking areas, driveways, walkways, landscaping and other site features shall be located and constructed consistent with:
 - a. A set of plans prepared by Spruhan Engineering, P.C., signed and stamped by Edmond Spruhan, Professional Engineer:
 - i. "Civil Plan 1", 290 Watertown Street, Newton, Massachusetts, dated 7/25/23, revised 05/06/2024.
 - b. Architectural plans entitled "290 Watertown Street Residences" prepared by, MGD dated February 26, 2023, Amended March 19, 2023, signed and stamped by Ronald Jarek, Registered Architect.
 - I. Front and Rear Elevations (page A2.01), dated 2/26/2023.
 - II. Right Side Elevations (page A2.02), dated 2/26/2023.
 - III. Left Side Elevations (page A2.03) dated 2/26/2023.

IV. Landscape Plan and Sustainability prepared by Ronald Jarek, Registered Architect, Page SD.05, dated 11/3/2023.

2. Prior to the issuance of any Building Permit, the petitioner shall provide a final Site Plan for review and approval by the Department of Planning and Development, Engineering Division of Public Works and Fire Department. The Site Plan shall show all parking areas to be compliant with dimensional requirements of the Newton Zoning Ordinance.
3. No Building Permit shall be issued pursuant to this Special Permit/Site Plan Approval until the petitioner has:
 - c. Recorded a certified copy of this Special Permit/Site Plan Approval at the Middlesex South Registry of Deeds and filed proof of such recording with the City Clerk and submitted a copy with the building permit application.
 - d. Provided a final Operations and Maintenance Plan (O&M) for stormwater management to the Engineering Division of Public Works for review and approval. Once approved, the O&M must be adopted by applicant, incorporated into the deeds; and recorded at the Registry of Deeds for the Southern District of Middlesex County. A certified copy of the O&M shall be submitted to the Engineering Division of Public Works.
 - e. Obtained a written statement from the Planning Department that confirms the Building Permit plans are consistent with plans approved in Condition #1 including all dimensional requirements.
4. The Petitioner shall do the following to remediate pest and rodent activity:
 - a. Prior to issuance of any demolition or building permit, the Petitioner, at its sole cost and expense, shall hire a licensed Pest Control Operator to assess the property for pest and rodent activity and develop and implement a pest remediation action plan to eliminate the activity and prevent off-site migration. The plan shall include the target pest, the methods for eliminating activity, and plan for preventing pest migration off-site during demolition and construction.
 - b. A copy of the Pest Control inspection report and the remediation action plan shall be submitted to the Inspectional Services Department for review and approval prior to issuance of any demolition or building permit. A copy of such approval shall be provided to the Department of Planning and Development.
 - c. The Pest Control Operator shall implement the approved remediation action plan, monitor the site for the duration of the project, and take whatever action the Operator deems necessary to control pest infestation and migration.
5. The petitioner shall comply with the Tree Preservation Ordinance.
6. All lighting fixtures shall be residential in scale.
7. All appliances and utilities for the building shall be all-electric, including heating and cooling.
8. All roofs shall be solar panel ready, garage spaces shall be EV-ready, and bicycle storage shall be provided in each garage space as shown on the plans referenced in Condition 1.

The petitioner shall provide evidence of such commitments prior to the issuance of a building permit.

9. Prior to the issuance of any Building Permit, the Petitioner shall submit a Construction Management Plan (the "CMP") for review and approval to the Commissioner of Inspectional Services, the Director of Planning and Development, the City Engineer, and the Chief of the Fire Department. The CMP shall be in compliance with all applicable policies and ordinances in effect at the time of submission. The Petitioner shall comply in all material respects with the Construction Management Plan, which shall be consistent with and not in conflict with relevant conditions of this Order and shall include, but not be limited to, the following provisions:
 - a. 24-hour contact information for the general contractor. This information shall also be posted in a clear and visible manner at the construction site.
 - b. The proposed schedule of the project, including the general phasing of the construction activities and anticipated completion dates and milestones.
 - c. Site plan(s) showing the proposed location of contractor and subcontractor parking, on-site material storage area(s), on-site staging areas(s) for construction materials and delivery vehicles and equipment, and location of any security fencing and erosion control.
 - d. A plan showing temporary pedestrian access within work zones in accordance with DPW Policy.
 - e. Proposed methods for dust control including, but not limited to: watering, covering trucks for transportation of excavated material; minimizing storage of debris on-site by using dumpsters and regularly emptying them; using tarps to cover piles of bulk building materials and soil; locating a truck washing station to clean muddy wheels on all truck and construction vehicles before exiting the site.
 - f. Proposed methods of noise control, in accordance with the Revised Ordinances, §20-13. Staging activities should be conducted in a manner that will minimize off-site impacts of noise. Noise producing staging activities should be located as far as practical from noise sensitive locations.
 - g. Tree preservation plan to define the proposed method(s) for protection of any existing trees to remain on site.
 - h. The CMP shall also address the following: safety precautions; anticipated dewatering during construction; site safety and stability; and impacts on abutting properties.
10. All construction activity shall be limited to 7:00AM-7:00PM Monday through Friday and 8:00AM-7:00PM on Saturdays, excluding federal, state, and local holidays, unless waived by the Mayor in accordance with Revised Ordinances, § 20-13.
11. The Petitioner shall install all landscaping consistent with this Special Permit/Site Plan approval and shall maintain landscaping in good condition, including plantings installed as part of green roof/carport. Any plant material that becomes diseased or dies shall be replaced as soon as feasibly possible with similar material.

12. No Final Inspection/Occupancy Permit for the use covered by this special permit/site plan approval shall be issued until the petitioners have:
 - a. Filed with the building permit application statements by a registered architect and a professional land surveyor certifying compliance with Condition #1.
 - b. Submitted final as-built survey plans in digital format, stamped and signed by a professional land surveyor or professional engineer, as applicable.



City of Newton, Massachusetts
Department of Planning and Development
1000 Commonwealth Avenue Newton, Massachusetts 02459
617-796-1120

Ruthanne Fuller
Mayor

Barney S. Heath
Director

PUBLIC HEARING MEMORANDUM

DATE: November 9, 2023

TO: City Council

FROM: Barney S. Heath, Director of Planning and Development
Katie Whewell, Chief Planner for Current Planning
Alyssa Sandoval, Deputy Chief Planner for Current Planning

SUBJECT: **Petition #240-23** Request to allow ground floor residential use, to exceed by right height and stories, at 290 Watertown Street, Ward 1, Newton, on land known as Section 11 Block 14 Lot 03, containing approximately 11,473 sq. ft. of land in a district zoned BUSINESS 1. Ref: 7.3.3, 4.4.1, 4.1.2.B.3, 4.1.3, 5.1.4, 5.1.13 of Chapter 30 of the City of Newton Rev Zoning Ord, 2017.

The purpose of this memorandum is to provide the City Council and the public with technical information and planning analysis conducted by the Planning Department. The Planning Department's intention is to provide a balanced review of the proposed project based on information it has at the time of the public hearing. Additional information about the project may be presented at or after the public hearing for consideration at a subsequent working session by the Land Use Committee of the City Council.



290 Watertown Street

Project Description

Background

The subject property consists of a long, rectangular 11,473-square foot parcel located at 290 Watertown Street. The property is improved with a non-conforming two-and-a-half story, two-family dwelling with a detached garage. The house was originally constructed in 1880 and the detached garage of the house is accessed by a single driveway on the right side of the lot.

The surrounding neighborhood is a mix of businesses and residential uses, including restaurants, stores, personal service businesses, multi-family residential developments, and two-story homes. The development is located in the commercial center of the Village of Nonantum on Watertown Street and on the MBTA Bus 59 line. Located within the Business Use 1 Zone (BU-1), the property abuts BU-1 zone properties to the west and north and Multi-Residence 2 (MR-2) zone to the east.

The petition was scheduled to be heard at the August 22, 2023 Land Use Committee meeting, but the item was held when the petitioner noted that the submitted plans would change because of ongoing neighbor discussions. The site plans were resubmitted and reflect several changes since the last submission including reduction of the proposed development from five units to four units; an increase in the overall size of each unit; and a decrease in the overall floor area ratio (FAR) of the project.

Special Permit

The petitioner requires special permit relief to allow ground floor residential in the BU-1 zone, to allow three stories, and allow buildings greater than 24 feet in height.

Analysis

The petitioner proposes to demolish the existing nonconforming dwelling and garage and construct four residential units in a 3-story, 10,735-square-foot building. The residential development also includes a centrally located covered carport with a green roof patio garden. As designed, the residential development will have sufficient parking meeting the parking requirements of the Newton Zoning Ordinance. Unit 1 will have a two-car garage, Units 2 and 3 will each have one-car garages and one stall within a carport and Unit 4 will have a two-car garage, for a total of eight parking stalls.

Planning does not have major concerns with the proposed residential use, and believes the overall scale is appropriate for the location, and surrounding neighborhood, which has a mix of commercial and residential uses. The small-scaled design of the building facing Watertown Street helps to reduce the overall visual mass of the 4-unit development from the street as does the lower height green roof and carport. In addition, the proposed development is well below the FAR allowed (1.5) and proposes a FAR of .95. Planning is supportive of the use of the green roof, which will provide an attractive outdoor space for use by residents and visually appealing to

abutters. Planning encourages the petitioner to plan for long-term maintenance of the green roof to ensure that it stays healthy after planting. Planning also recommends that the permeable walkway along the driveway is demarcated with a different paver style or color to indicate the walking area.

Because the units have been reduced from a total of five units to four units, there is no longer a fee for sewer infiltration/inflow (I&I). In addition, the reduction of the development from five to four units allowed the site to accommodate the required parking and a parking waiver is not required.

I. Zoning Relief Requested:

Zoning Relief Required		
<i>Ordinance</i>	<i>Requested Relief</i>	<i>Action Required</i>
§4.4.1	To allow ground floor residential	S.P. per §7.3.3
§4.1.2.B.3	To allow three stories	S.P. per §7.3.3
§4.1.3	To allow buildings greater than 24 feet in height	S.P. per §7.3.3

II.

For more details around the zoning analysis please refer to **Attachment A**.

III. Criteria for Consideration per §7.3.3 and/or §5.1.13:

- The site is an appropriate location for the proposed 4-unit, three-story residential development with ground level parking. (§7.3.3.1)
- The proposed 4-unit, three-story residential development with ground floor residential will not adversely affect the neighborhood. (§7.3.3.2)
- There will not be a nuisance or serious hazard to vehicles or pedestrians. (§7.3.3.3)
- Access to the site is appropriate for the types and numbers of vehicles involved. (§7.3.3.4)

IV. Project Proposal and Site Characteristics

A. Site

The site consists of one long, narrow 11,473 square-foot parcel at 290 Watertown Street in the BU-1 zone. The property is improved with a two-story, 29-foot high,

two-unit multi-family dwelling.

The lot slopes down gradually from the front to the rear of the property about five feet in total. Vehicular access to the property is provided by a curb cut and 12.1-foot-wide driveway located along the front, right side of the property, which leads to a detached two-car garage. In the area between the house and garage is an asphalt driveway area and small patio area as well as concrete debris. Behind the garage and patio at the rear of the lot is an extensive undeveloped rear yard area which includes two trees and grass.

development with ground level garages, dedicated patios, and outdoor space. The residential development also includes a central carport for two parking stalls covered with a green roof patio garden. As designed, the residential development will have sufficient parking and meets the parking requirements of the Newton Zoning Ordinance. Unit 1 will have a two-car garage, Units 2 and 3 will each have one-car garages and one stall each within the carport and Unit 4 will have a two-car garage, for a total of eight parking stalls. A special permit is required to expand the ground floor residential use with above residential use in a BU-1 district.

As designed, the proposed development requires dimensional relief for the height and number of stories.

The existing structure has a nonconforming height of 29 feet, where 24 feet is the maximum allowed. The proposed residential structure would be slightly higher than the existing structure at 31.97 feet, which requires a special permit to allow the additional height above 24 feet. In addition, the structure is three stories where two stories are allowed by right in the BU-1 zoning district. Three-story buildings require a special permit in the BU-1 zoning district.

The proposed development meets all the required rear, side, and front yard setbacks for the BU-1 zoning district and provides a slightly larger front yard setback of 8.0 feet, correcting a non-conforming existing front setback of 6.7 feet. It also slightly enlarges the side yard setbacks compared to the existing house.

Individual
Fenced Yards
& Patios

Carport with
proposed Second
Floor Green Roof

Driveway from
Watertown Street

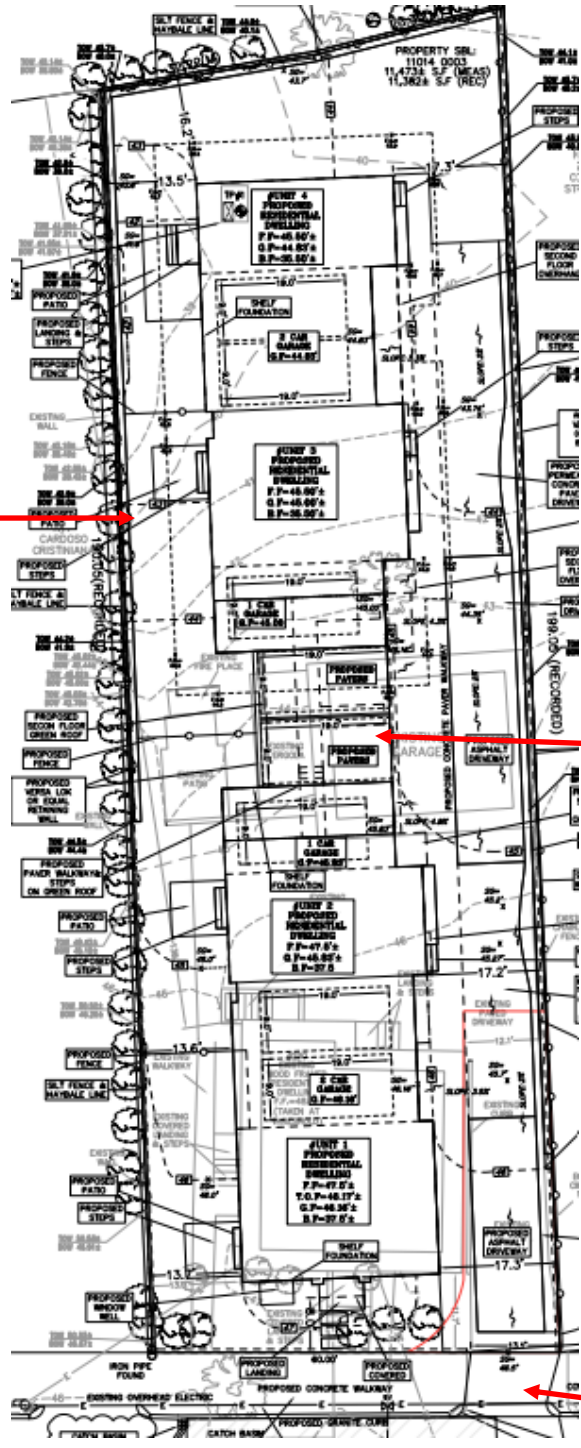

The units are a mix of three and four-bedrooms, and range in size from 2,436 square feet to 2,936 square feet. Unit 1 is 2,936 square feet, Unit 2 is 2,518 square feet, Unit 3 is 2,515 square feet, and Unit 4 is 2,766 square feet. The proposed front elevation on

Watertown Street appears to be in keeping with neighboring properties and presents as a single-family dwelling. The front elevation features architectural elements, such as a front door entry with porch and dormer, which resemble a single-family. The overall mass of the building from the original submission is reduced with the inclusion of the single-story carport area between the higher building heights of Units 1 & 2 and Units 3 & 4.

Proposed Front Elevation of Unit 1 (Watertown Street)



Proposed Right Elevation (Units 1 & 2 only)



Proposed Right Elevation (Units 3 & 4 only)



Proposed Left Elevation (Units 1, 2, 3 &4)



Planning does not have concerns with the proposed multi-family residential use at this location and within the surrounding neighborhood, which has a mix of businesses and residences. The proposed development is located on the main street of Watertown Street, close to restaurants, stores, personal service businesses, multi-family residential developments, and two-story homes, and the MBTA Bus 59 line.

C. Parking and Circulation

Per section 5.1.4 of the NZO, two parking stalls are required per each dwelling unit. With four units, eight stalls are required. Unit 1 will have a two-car garage, Units 2 and 3 will each have one-car garages and one stall within a carport and Unit 4 will have a two-car garage, for a total of eight parking stalls, meeting the requirement of 5.1.4.

The parking garages and carport would be accessed via a driveway on the right side of the property. As noted in the attached engineering review memorandum, a turning template plan was requested to be submitted to demonstrate maneuvering of various vehicle pulling into each garage and backing out to exit the site. The petitioner has provided the turning plan in its latest submission for the Associate City Engineer to review.

The parking areas and units will be accessed by a 17.2-foot wide driveway and pedestrian pathway. The driveway is accessed by a 13.1-foot-wide curb cut from Watertown Street in the same location as the existing curb cut. Planning does not have concerns with the use of the existing driveway to access these units. Planning recommends that the paver walkway along the left side of the driveway is demarcated with a different paver style or color to indicate the walking area.

D. Landscaping

A Landscape Plan is provided for the project. Each unit has an exterior patio and fenced dedicated outdoor space. A retaining wall is proposed along the property line as well as a wood privacy fence. The landscape plan notes variety of arborvitae and cedars and privacy fence screening neighbors along the western property line and privacy fence and additional landscaping along the eastern property line, where the driveway is located.

The perimeter of the front yard the adjacent to Watertown Street includes the planting of smaller shrubs, such as inkberry and boxwood.

E. Sustainability

The size of the project does not trigger the sustainable development requirements in Section 5.13 of the Zoning Ordinance, however the petitioner has committed to sustainable features. The petitioner has sustainability features noted on the Landscape Plan, including solar ready roofs; EV chargers for garages; green roof, and all electric home and appliances. The installation of bike storage is a welcome feature. The Newton Energy Coach Liora Silkes notes that ensuring the roof is solar ready is a beneficial feature of the project.

VI. INTERDEPARTMENTAL REVIEW

- A. Historic Review: On August 31, 2022, the house and garage were determined not to be preferably preserved by the Newton Historical Commission in its Demolition Review and no further review was required.
- B. Tree Warden: Marc Welch has reviewed the landscape plan and the trees proposed are reasonable. In general, tree plantings should be no taller than 8 to 10 feet high to be manageable. The Nyssa tree should be no taller than 12 feet at installation, preferably smaller. They can have a hard time establishing and planting a smaller tree makes it easier to adapt to the site and survive.
- C. Urban Design Commission: The UDC reviewed the project at its January 12, 2023 meeting. The UDC noted that the single-family building along the main frontage was particularly well-designed. The proposed design has since changed from this initial design from five units to four units, and the Urban Design Commission has not seen the revised design. See **Attachment C**.
- D. Engineering Review: The Engineering Division has reviewed the proposal. In its attached memorandum (**Attachment D**) that office notes, among other comments, that a turning template plan and snow storage plan is recommended for this project. The petitioner has since provided the turning template plan. In addition, a construction management plan (CMP) is needed for this project.

Because the development has been reduced to four residential units, there is no additional sewer infiltration/inflow (I&) mitigation fee.

VII. PETITIONER'S RESPONSIBILITIES

The petitioner should review and respond to the issues noted in this memo regarding landscaping and walkway design. Otherwise, this petition is considered complete.

ATTACHMENTS:

- Attachment A:** Zoning Review Memorandum
- Attachment B:** DRAFT Council Order
- Attachment C:** UDC Memo
- Attachment D:** Engineering Review Memo



Ruthanne Fuller
Mayor

City of Newton, Massachusetts
Department of Planning and Development
1000 Commonwealth Avenue Newton, Massachusetts 02459

Attachment A

Telephone
(617) 796-1120
Telefax
(617) 796-1142
TDD/TTY
(617) 796-1089
www.newtonma.gov

Barney S. Heath
Director

ZONING REVIEW MEMORANDUM

Date: October 31, 2023

To: Anthony Ciccarillo, Commissioner of Inspectional Services

From: Jane Santosuosso, Chief Zoning Code Official
Katie Whewell, Chief Planner for Current Planning

Cc: Laurance Lee, Attorney
290 Watertown St LLC, Applicant
Barney S. Heath, Director of Planning and Development
Jonah Temple, Deputy City Solicitor

RE: Request to allow ground floor residential use, and to exceed by right height and stories

Applicant: 290 Watertown St LLC	
Site: 290 Watertown Street	SBL: 11014 0003
Zoning: BU1	Lot Area: 11,473 square feet
Current use: Two-family dwelling	Proposed use: Five residential dwelling units

BACKGROUND:

The property at 290 Watertown Street consists of 11,473 square feet and is improved with a nonconforming two-family dwelling constructed circa 1880 and a detached garage in the BU1 zoning district. The petitioner proposes to demolish the dwelling and detached garage and construct four residential dwelling units in one building.

The following review is based on plans and materials submitted to date as noted below.

- Zoning Review Application, prepared by Laurance Lee, attorney, submitted 3/29/2023
- Existing Site Plan, signed and stamped by Christopher C. Charlton, surveyor, dated 8/14/2022
- Civil Plan, signed and stamped by Christopher C. Charlton, surveyor and Edmond T. Spruhan, engineer, dated 3/16/2023, revised 7/25/2023, 10/25/2023
- Architectural Site Plan, signed and stamped by Ronald F. Jarek, architect, dated 2/14/2022
- Schematic Design Set, signed and stamped by Ronald F. Jarek, architect, dated 9/29/2023

ADMINISTRATIVE DETERMINATIONS:

1. The petitioners propose to raze the existing two-family dwelling and detached garage and construct four residential dwelling units in one building. Per section 4.4.1, a special permit is required to allow ground floor residential use with residential use above.
2. Per section 4.1.2.B.3 a building in the BU1 district is allowed two stories by right and up to three by special permit. The petitioner proposes three-story structures, requiring a special permit.

Per section 4.1.3 the maximum FAR for a three-story structure is 1.50. The petitioners propose an FAR of .95.

3. Per section 4.1.3 a building in the BU1 district may be up to 24 feet in height by right and up to 36 feet by special permit. The building is proposed with a height of 31.97 feet, requiring a special permit.
4. Per section 5.1.4, two parking stalls are required per each dwelling unit. With four units, eight stalls are required. Unit 1 will have a two-car garage, Units 2 and 3 will each have one-car garages and one stall within a carport and Unit 4 will have a two-car garage, for a total of eight parking stalls, meeting the requirement of 5.1.4.

BU1 Zone	Required	Existing	Proposed
Lot Size	10,000 square feet	11,473 square feet	No change
Setbacks			
• Front	7.2 feet (average)	6.8 feet	8 feet
• Side	15 feet (1/2 Bldg Height)	13.3 feet	13.5 feet
• Side	15 feet (1/2 Bldg Height)	12.1 feet	17.2 feet
• Rear	15 feet (1/2 Bldg Height)	138.6 feet	16.2 feet
Building Height	24 feet (36 feet by SP)	29 feet	31.97 feet*
Max Number of Stories	2.5 (3 by SP)	2.5	3*
Lot Area Per Unit	1,200 square feet	5,737 square feet	2,868 square feet
FAR	1.5 (3 stories)	Not available	.95

See “Zoning Relief Summary” below:

Zoning Relief Required		
<i>Ordinance</i>	<i>Requested Relief</i>	<i>Action Required</i>
§4.4.1	To allow ground floor residential	S.P. per §7.3.3
§4.1.2.B.3	To allow three stories	S.P. per §7.3.3
§4.1.3	To allow buildings greater than 24 feet in height	S.P. per §7.3.3

CITY OF NEWTON

IN CITY COUNCIL

ORDERED:

That the City Council, finding that the public convenience and welfare will be substantially served by its action, that the use of the site will be in harmony with the conditions, safeguards and limitations set forth in the Zoning Ordinance, and that said action will be without substantial detriment to the public good, and without substantially derogating from the intent or purpose of the Zoning Ordinance, which grants approval of the following SPECIAL PERMIT/SITE PLAN APPROVAL to allow ground floor residential use, to exceed by right height and stories, and a parking waiver as recommended by the Land Use Committee for the reasons given by the Committee, through its Chairman, Councilor Richard Lipof:

1. The specific site is an appropriate location for the proposed four-unit residential development, which includes ground level residential and three stories in a BU-1 district. The scale and design of the proposed development is appropriate for the location, and surrounding neighborhood, which has a mix of businesses and residences, including restaurants, stores, personal service businesses, multi-family residential developments, and two-story homes. (§4.1.3, §4.4.1, §7.3.3.C.1)
2. The proposed four units in a three-story building will not adversely affect the neighborhood because the maximum height of the building is similar to what currently exists on the site. The building includes varying heights and a second story green roof, which helps to reduce the overall visual mass of the structure. (§4.1.3, §4.4.1, §7.3.3.C.2)
3. The proposed four units in one building located in a walkable neighborhood will not create a nuisance or serious hazard to vehicles or pedestrians. (§4.1.3, §7.3.3.C.3)
4. Access to the site over streets is appropriate for the types and numbers of vehicles involved. (§7.3.3.C.4)

PETITION NUMBER: #240-23

PETITIONER: 290 Watertown Street LLC

LOCATION: 290 Watertown Street, on land known as Section 11 Block 14 Lot 3, containing approximately 11,473 sq. ft.

OWNER: 290 Watertown Street LLC

ADDRESS OF OWNER: 290 Watertown Street LLC
20 Holly Street
Salem, MA 01970

TO BE USED FOR: Four dwelling units

CONSTRUCTION: Wood Frame

EXPLANATORY NOTE: Special permit per §4.4.1 to allow ground level residential use, §4.1.2.B.3 allow a three-story structure, §4.1.3 allow buildings greater than 24 feet in height

ZONING: Business Use 1

Approved, subject to the following conditions:

1. All buildings, parking areas, driveways, walkways, landscaping and other site features shall be located and constructed consistent with:
 - a. A set of plans prepared by Spruhan Engineering, P.C., signed and stamped by Edmond Spruhan, Professional Engineer:
 - i. "Civil Plan", 290 Watertown Street, Newton, Massachusetts, dated 5/26/23, revised 11/02/23.
 - b. Architectural plans entitled "290 Watertown Street Residences" prepared by, MGD dated November 3, 2023, signed and stamped by Ronald Jarek, Registered Architect
 - i. Elevations (page 5), signed and stamped by Ronald Jarek, Registered Architect
 - ii. Landscape Plan prepared by Ronald Jarek, Registered Architect, Page 8.
2. Prior to the issuance of any Building Permit, the petitioner shall provide a final Site Plan for review and approval by the Department of Planning and Development, Engineering Division of Public Works and Fire Department. The Site Plan shall show all parking areas to be compliant with dimensional requirements of the Newton Zoning Ordinance.
3. No Building Permit shall be issued pursuant to this Special Permit/Site Plan Approval until the petitioner has:

- a. Recorded a certified copy of this Special Permit/Site Plan Approval at the Middlesex South Registry of Deeds and filed proof of such recording with the City Clerk and submitted a copy with the building permit application.
 - b. Provided a final Operations and Maintenance Plan (O&M) for stormwater management to the Engineering Division of Public Works for review and approval. Once approved, the O&M must be adopted by applicant, incorporated into the deeds; and recorded at the Registry of Deeds for the Southern District of Middlesex County. A certified copy of the O&M shall be submitted to the Engineering Division of Public Works.
 - c. Obtained a written statement from the Planning Department that confirms the Building Permit plans are consistent with plans approved in Condition #1 including all dimensional requirements.
4. The Petitioner shall do the following to remediate pest and rodent activity:
- a. Prior to issuance of any demolition or building permit, the Petitioner, at its sole cost and expense, shall hire a licensed Pest Control Operator to assess the property for pest and rodent activity and develop and implement a pest remediation action plan to eliminate the activity and prevent off-site migration. The plan shall include the target pest, the methods for eliminating activity, and plan for preventing pest migration off-site during demolition and construction.
 - b. A copy of the Pest Control inspection report and the remediation action plan shall be submitted to the Inspectional Services Department for review and approval prior to issuance of any demolition or building permit. A copy of such approval shall be provided to the Department of Planning and Development.
 - c. The Pest Control Operator shall implement the approved remediation action plan, monitor the site for the duration of the project, and take whatever action the Operator deems necessary to control pest infestation and migration.
5. The petitioner shall comply with the Tree Preservation Ordinance.
6. All lighting fixtures shall be residential in scale.
7. All appliances and utilities for the building shall be all-electric, including heating and cooling.
8. All roofs shall be solar panel ready, garage spaces shall be EV-ready, and bicycle storage shall be provided in each garage space as shown on the plans referenced in Condition 1. The petitioner shall provide evidence of such commitments prior to the issuance of a building permit.
9. Prior to the issuance of any Building Permit, the Petitioner shall submit a Construction Management Plan (the "CMP") for review and approval to the Commissioner of Inspectional Services, the Director of Planning and Development, the City Engineer, and the Chief of the Fire Department. The CMP shall be in compliance with all applicable policies and ordinances in effect at the time of submission. The Petitioner shall comply in all material respects with the Construction Management Plan, which shall be

consistent with and not in conflict with relevant conditions of this Order and shall include, but not be limited to, the following provisions:

- a. 24-hour contact information for the general contractor. This information shall also be posted in a clear and visible manner at the construction site.
 - b. The proposed schedule of the project, including the general phasing of the construction activities and anticipated completion dates and milestones.
 - c. Site plan(s) showing the proposed location of contractor and subcontractor parking, on-site material storage area(s), on-site staging areas(s) for construction materials and delivery vehicles and equipment, and location of any security fencing and erosion control.
 - d. A plan showing temporary pedestrian access within work zones in accordance with DPW Policy.
 - e. Proposed methods for dust control including, but not limited to: watering, covering trucks for transportation of excavated material; minimizing storage of debris on-site by using dumpsters and regularly emptying them; using tarps to cover piles of bulk building materials and soil; locating a truck washing station to clean muddy wheels on all truck and construction vehicles before exiting the site.
 - f. Proposed methods of noise control, in accordance with the Revised Ordinances, §20-13. Staging activities should be conducted in a manner that will minimize off-site impacts of noise. Noise producing staging activities should be located as far as practical from noise sensitive locations.
 - g. Tree preservation plan to define the proposed method(s) for protection of any existing trees to remain on site.
 - h. The CMP shall also address the following: safety precautions; anticipated dewatering during construction; site safety and stability; and impacts on abutting properties.
10. All construction activity shall be limited to 7:00AM-7:00PM Monday through Friday and 8:00AM-7:00PM on Saturdays, excluding federal, state, and local holidays, unless waived by the Mayor in accordance with Revised Ordinances, § 20-13.
 11. The Petitioner shall install all landscaping consistent with this Special Permit/Site Plan approval and shall maintain landscaping in good condition, including plantings installed as part of green roof/carport. Any plant material that becomes diseased or dies shall be replaced as soon as feasibly possible with similar material.
 12. No Final Inspection/Occupancy Permit for the use covered by this special permit/site plan approval shall be issued until the petitioners have:
 - a. Filed with the building permit application statements by a registered architect and a professional land surveyor certifying compliance with Condition #1.
 - b. Submitted final as-built survey plans in digital format, stamped and signed by a professional land surveyor or professional engineer, as applicable.



Ruthanne Fuller
Mayor

City of Newton, Massachusetts
Department of Planning and Development
Urban Design Commission

Telephone
(617) 796-1120
Telefax
(617) 796-1142
TDD/TTY
(617) 796-1089
www.newtonma.gov

Barney Heath
Director

DATE: March 10, 2023
TO: Katie Whewell, Chief Planner
FROM: Urban Design Commission
RE: 290 Watertown Street Design Review
CC: Barney Heath, Director of Planning and Community Development
Jennifer Caira, Deputy Director
Land Use Committee of the City Council
Petitioner

Section 22-80 of the Newton City Ordinances authorizes the Urban Design Commission to act in an advisory capacity on matters of urban design and beautification. At their regular meeting on January 12, 2023, the Newton Urban Design Commission (UDC) reviewed the proposed project at 290 Watertown Street for design. The Urban Design Commission had the following comments and recommendations:

The UDC commented that the project looks good and like how the project meets the street, the scale works well on the street.

- The UDC commented that unit one along Watertown Street is a positive approach, it's the most positive aspect of the project. The project meets the street in a good way which is very important and keeping the scale in a more traditional look there.
- One of the members asked why are there separations between the homes? Why aren't they just townhouses that are all attached to each other? The applicant responded that they looked at that originally but not having that separation, it will be one massive building on site so wanted to create the small separation between the units and provide access to the rear yard areas. Also want to be able to have three separate buildings, where each one, as you go back into site, drops about a foot and there's always a 30-foot roofline as it keeps going down with the buildings on site. The UDC responded that it's possible to do that whether they are attached or not, these little spaces seem funny and not sure what is accomplished by that. One member commented the space between buildings look okay, can imagine kids playing in the backyard and wanting to get around to the front so they can go through the slits to go in the front. One member responded that the kids could go through the carport, they are going to be funny little spaces that are going to be dark and probably moldy, no sun will not get in there.

- The UDC asked why is there no window for the last unit, next to the unit entry on the gable portion on the right-side elevation? It's like other unit's floor plan and other units have a window so why not this last unit? The applicant responded that they could potentially add a window since the layouts are similar.
- The UDC commented what is supposed to look like dormers, especially on building 2 doesn't look like dormers because there's no setback, on either side of them. Fake dormer look doesn't work architecturally, the roofs are very low sloped. The applicant responded that the third story is just a look they are creating with that kind of roof line coming down where they could potentially be a different material, such as metal or something else. The UDC commented that architecturally fake dormer look is not successful. It's a little bulky and it looks bulky because the applicant is trying to make it look less bulky, the biggest issue is the non-dormer dormers. One member commented that they agree with the comment, but you'd never get far enough away from the building to know whether it's a real dormer or not so doesn't appear to be an issue.
- The UDC commended the applicant for not overdoing with materials, it's nice to see just a couple of materials, dark brown and white color combination looks good.
- The UDC would like to learn more about the project next door at 296 Watertown Street.
- The UDC asked about the width of the driveway? The applicant responded that its about 16 feet including the walkway. Staff commented that they believe the fire department requires driveway to be at least 18 feet wide and recommended to check with the fire department about the driveway width.

CITY OF NEWTON
Department of Public Works
ENGINEERING DIVISION

MEMORANDUM

To: Council Rick Lipof, Land Use Committee Chairman

From: John Daghlian, Associate City Engineer

Re: Special Permit – 290 Watertown Street

Date: June 29, 2023

CC: Barney Heath, Director of Planning
Jennifer Caira, Deputy Director
Katie Whewell, Chief Planner
Alyssa Sandoval, Deputy Chief Planner
Lou Taverna, PE City Engineer
Michael Gleba, Sr. Planner

In reference to the above site, I have the following comments for a plan entitled:

*290 WATERTOWN STREET
NEWTON
MASSACHUSETTS*

Prepared by: Spruhan Engineering
Dated: 5/30/2023

Executive Summary:

This proposed permit entails the demolition of an existing two-family unit and the construction of a 5-unit residential dwelling. The site has 60-feet of frontage along Watertown Street to the north, and residential dwellings to the south, east and western property lines. The site plan has a north arrow that is incorrectly rotated 180°. A high point elevation of 47-feet is near the front of the home and slopes gently to the northwest to a low point of 39-feet. The new dwelling will have on grade garages, a turning template plan should be submitted to demonstrate proper

maneuvering of various vehicle pulling into each garage and backing out to exit the site. I have a concern for snow removal and storage the applicant needs to explain where snow will be stored as the site does not have much open space along the driveway. On the average a 3-foot-high retaining wall within the setback is proposed along the east, south and western property lines the design needs to ensure that natural surface water flows are not impacted. The wall allows for the construction of flat side yards of patios and the access driveway.

The engineer of record has designed a stormwater collection system that meets the DEP & DPW Stormwater Regulations by collecting and infiltrating runoff from the driveway & roof within 14- infiltration units along the western & northern property lines. The proposed Operations & Maintenance (O&M) plan is acceptable for the design intent, however access to the units maybe problematic. A minor addition is need for the proposed infiltration system; the City requires a 3" thick layer of peastone with filter fabric above & below the peastone covering the entire system as shown below.

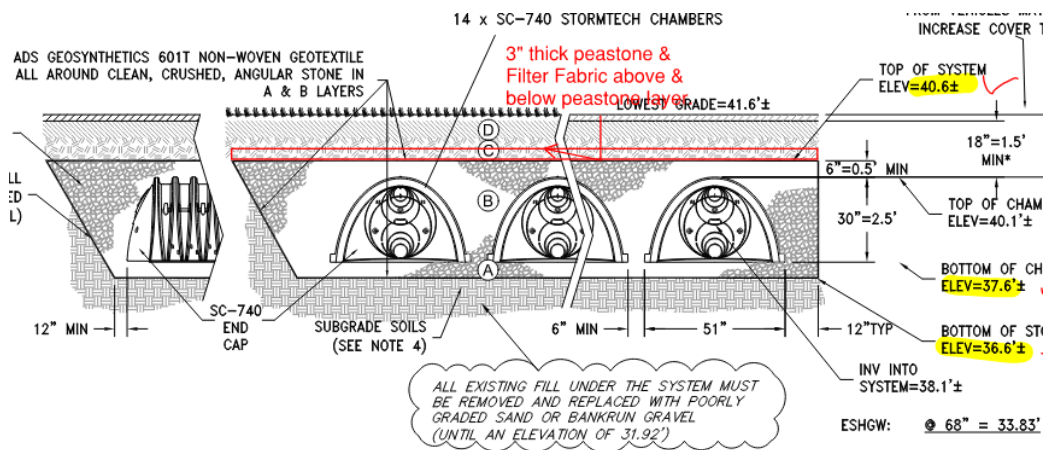

In accordance with the City Ordinance B-52 new concrete sidewalk, and granite curbing is required.



Construction Management:

1. A construction management plan is needed for this project. At a minimum, it must address the following: staging site for construction materials and equipment, parking for construction workers vehicles, phasing of the project with anticipated completion dates and milestones, safety precautions, emergency contact personnel of the general contractor. It shall also address anticipated dewatering during construction, site safety & stability, siltation & dust control and noise impact to abutters.
2. Stabilized driveway construction entrance(s) will be required for the duration of the construction which will provide a truck wash to prevent tracking of mud and silt onto City streets.
3. Catch basins within and downstream of the construction zone will be required to have siltation control installed for the duration of the project and must be identified on the site plan.

Drainage:

1. Should this permit application be approved the O&M must be adopted by the applicant/property owner, incorporated into the deeds; and recorded at the Middlesex Registry of Deeds before a building permit is issued. A copy of the recording instrument shall be submitted to the Engineering Division.
2. It is imperative to note that the ownership, operation, and maintenance of the proposed drainage system and all appurtenances including but not limited to the drywells, catch basins, trench drains, and pipe(s) are the sole responsibility of the property owner(s).

Environmental:

1. Has a 21E Investigation and report been performed on the site, if so, copies of the report should be submitted to the Newton Board of Health and Engineering Division.
2. Are there any existing underground oil or fuel tanks? Have they been removed, if they have been, evidence of the proper removal should be submitted to the Newton Fire Department and the Board of Health.

Sanitary Sewer & Domestic Water Service(s):

1. Existing water and sewer services to building(s) shall cut and capped at the respective mains and completely removed from the main(s) and its entire length and properly backfilled. The Engineering Division must inspect and approve this work, failure to having this work inspected will result in delay of issuance of the new Utility Connection or issuance of a Certificate of Occupancy.
2. All new sewer service(s) shall be pressure tested in accordance with the City Construction Specifications & Standards and inspected via Closed Circuit Television CCTV inspection after installation is completed. A copy of the video inspection and written report shall be submitted to the City Engineer or his representative. The sewer service will NOT be accepted until the two methods of inspection are completed AND witnessed by a representative of the Engineering Division. A Certificate of Occupancy will not be recommended until these tests are completed to the satisfaction of the City Engineer.
3. All sanitary sewer manhole(s) shall be vacuum tested in accordance to the City's Construction Standards & Specifications, the sewer service and manhole will NOT be accepted until the manhole(s) pass the testing requirements. All testing MUST be witnessed by a representative of the Engineering Division. A Certificate of Occupancy will not be recommended until this test is completed to the satisfaction of the City Engineer and a written report of the test results is submitted to the City Engineer.
4. With the exception of natural gas service(s), all utility trenches within the right of way shall be backfilled with Control Density Fill (CDF) Excavatable Type I-E up to within 18-inches of the asphalt binder level, after which Dense Grade Gravel compacted to 95 % Proctor Testing shall be placed over the CDF. Details of this requirement is the Engineering Division website "Standard Construction Details".
5. All water services shall be chlorinated, and pressure tested in accordance with the AWWA and the City Construction Standards & Specifications prior to coming online. These tests MUST be witnessed by a representative of the Engineering Division.

6. Approval of the final configurations of the water service(s) shall be determined by the Utilities Division, the engineer of record shall submit a plan to the Director of Utilities for approval.

General:

1. 5 Year Moratorium – if at time of construction the roadway is under a 5-year moratorium, the roadway must be milled and paved gutter-to-gutter for a distance of 25 feet in each direction from the outermost trenches.
2. All trench excavation shall comply with Massachusetts General Law Chapter 82A, Trench Excavation Safety Requirements, and OSHA Standards to protect the general public from unauthorized access to unattended trenches or excavations. Trench Excavation Permit is required prior to any construction. This applies to all trenches on public and private property. *This note shall be incorporated onto the final plans.*
3. All tree removal shall comply with the City's Tree Ordinance.
4. The contractor of record is responsible for contacting the Engineering Division and scheduling an appointment 48-hours prior to the date when the utilities will be made available for an inspection of water services, sewer services and drainage system installation. The utility in question shall be fully exposed for the Inspector to view, backfilling shall only take place when the City Engineer's Inspector has given their approval. *This note shall be incorporated onto the final plans.*
5. The applicant shall apply for a Building Permit with the Inspectional Services Department prior to ANY construction.
6. Before requesting a Certificate of Occupancy, an As Built plan shall be submitted to the Engineering Division in both digital and paper format. The plan shall show all utilities and final grades, any easements and improvements and limits of restoration. The plan shall include profiles of the various new utilities including but not limited to rim & invert elevations (City of Newton Datum), slopes of pipes, pipe materials, and swing ties from permanent building corners. The as built shall be stamped by both a Massachusetts Registered Professional Engineer and Registered Professional Land Surveyor. Once the As built plan is received the Engineering Division shall perform a final site inspection and then make a determination to issue a Certificate of Occupancy. *This note shall be incorporated onto the final plans.*

7. All site work including trench restoration, sidewalk, curb, apron, and loam border (where applicable) shall be completed before a Certificate of Occupancy is issued. *This note shall be incorporated onto the final plans.*
8. The contractor of record shall contact the Newton Police Department 48-hours in advanced and arrange for Police Detail to help residents and commuters navigate around the construction zone.
9. If any changes from the final approved design plan that are required due to unforeseen site conditions, the contractor of record shall contact the design engineer of record and submit revised design and stamped full scale plans for review and approval prior to continuing with construction.
10. *The engineer of record shall add the following attestation to the plans when applying for a building permit:*

I certify that the construction so shown was inspected prior to backfill and that all work conforms with the Approved Plan and meets or exceeds the City of Newton Construction Standards.

Signature

Note: If the plans are updated it is the responsibility of the applicant to provide all City Departments [ISD, Conservation Commission, Planning and Engineering] involved in the permitting and approval process with complete and consistent plans.

If you have any questions or concerns, please feel free to contact me at 617-796-1023.