

CITY OF NEWTON
IN BOARD OF ALDERMEN
PROGRAMS AND SERVICES COMMITTEE AGENDA

WEDNESDAY, SEPTEMBER 17, 2014

7:45 PM
Room 222

ITEMS SCHEDULED FOR DISCUSSION:

REFERRED TO PROGRAMS & SERVICES AND FINANCE COMMITTEES

- #333-14 COMMUNITY PRESERVATION COMMITTEE recommending the appropriation of four hundred seventy-six thousand seven hundred eighty dollars (\$476,780) to the Parks and Recreation Department to preserve, restore, and rehabilitate historic Farlow Park, as described in the proposal and supplemental materials submitted to the Community Preservation Committee from November 2013 to April 2014. [08/06/14 @ 4:16 PM]
- #254-12(2) THE PROGRAMS & SERVICES COMMITTEE recommending an ordinance to ban single-use plastic bags at certain retail establishments in the City of Newton. [01/10/14 @ 3:36 PM]
- #340-14 ALD. NORTON requesting to amend the City of Newton Charter to also include the term “Alderswoman” in text that refers to individuals who serve on the Board of Aldermen as “Aldermen”. [09/08/14 @ 4:10PM]

The location of this meeting is handicap accessible and reasonable accommodations will be provided to persons requiring assistance. If you need a special accommodation, please contact John Lojek, at least two days in advance of the meeting: jlojek@newtonma.gov, or 617-796-1064. For Telecommunications Relay Service dial 711.

ITEMS NOT SCHEDULED FOR DISCUSSION:

#339-14 ALD. HESS-MAHAN AND SANGIOLO requesting discussion with the Mayor's Office, the Law Department and the Clerk's Office concerning training of staff and members of Commissions, Boards and Committees to ensure compliance with the requirements of the Open Meeting Law Commissions, particularly with respect to meeting minutes. [09/05/14 @ 2:40PM]

REFERRED TO PROGRAMS & SERVICES AND FINANCE COMMITTEES

#216-14 ALD. HESS-MAHAN, ALBRIGHT, BAKER, CROSSLEY, NORTON AND SANGIOLO proposing the following amendments to Chapter 12 Health and Human Services of the Revised Ordinances to:

- require owners of dwellings requiring a Certificate of Habitability under Section 12-1 and real estate agents/brokers who receive compensation in connection with the particular real estate transaction to notify the Commissioner of Health and Human Services whenever an apartment, tenement, or room in a lodging house is vacated by the occupant or when an area in an existing building is converted to a condominium prior to being reoccupied by a new tenant, lodger or occupant;
- require educational institutions to disclose addresses of undergraduates living off-campus in Newton;
- require a fee for certification; and
- impose a fine for violation of these provisions. [05/14/14 @ 11:51 AM]

REFERRED TO PROGRAMS & SERVICES AND PUBLIC FACILITIES COMMITTEES

#119-14 ALD. ALBRIGHT AND CROSSLEY requesting discussion with the Inspectional Services Department to explain the development of short and long term plans to identify and correct buildings, sidewalks, playgrounds, etc., that do not conform to American Disability Act (ADA) standards. The discussion should include information on how improvements will be incorporated into the Capital Improvement Plan or if less than \$75,000 into a comprehensive budget plan to correct ADA deficiencies. [03/12/14 @ 4:18 PM]

#59-14 ALD. HESS-MAHAN AND BLAZAR requesting discussion with the Executive Department and the Health Care Advisory Committee concerning plans to implement recommendations contained in the First Report of the Health Care Advisory Committee to control the cost of health insurance while improving or maintaining the quality of care. [02/18/14 @ 6:39 PM]

REFERRED TO FINANCE AND PROGRAMS & SERVICES COMMITTEE

#402-13 ALD. FULLER, GENTILE, RICE and LINSKY requesting a Home Rule Petition to amend Article 9 of the Charter to clarify that Neighborhood Area Councils shall maintain and control their own financial accounts and records, independent of City finances; and to further clarify that such independent financial accounts and records shall remain subject to City audit. [10/28/13 @ 10:18 AM]

- #399-13 ALD. LINSKY, HESS-MAHAN, ALBRIGHT, CROSSLEY, DANBERG, BLAZAR, LAREDO & SCHWARTZ requesting to re-charge a task force to devise recommendations as to best practices and/or potential regulatory approaches to achieve improvements regarding the use of leaf blowers in the City of Newton. [10/28/13 @ 7:01 PM]
- #398-13 ALD. BAKER & DANBERG requesting a discussion of a possible ordinance, regulations or otherwise, to complement zoning regulation of any licensed Registered Marijuana Dispensaries to respond to any secondary impacts so as to make the operation of such dispensaries as successful as possible. [10/28/13 @ 10:00 AM]
- #199-13 ALD. JOHNSON AND SANGIOLO requesting an update from the School Committee and School Department regarding the request from the Board of Aldermen to reduce the family cap on activity fees. [05/20/13 @ 11:05 PM]
- #95-13(2) THE PROGRAMS & SERVICES COMMITTEE requesting an update from the Health Care Advisory Committee. [09/12/13 @ 9:49AM]
- #34-13 ALD. DANBERG, ALBRIGHT, BLAZAR, RICE, LINSKY AND CROSSLEY requesting a prohibition on polystyrene-based disposable food or beverage containers in the City of Newton if that packaging takes place on the premises of food establishments within the City. [01/03/13 @ 11:01 AM]
- #334-12 ALD. SWISTON AND LINSKY requesting a discussion with the Licensing Board regarding the licensing and permit requirements for non-profit organizations. [10/10/12 @ 3:52 PM]

REFERRED TO FINANCE AND APPROPRIATE COMMITTEES

- #257-12 RECODIFICATION COMMITTEE recommending (1) review of the Fees, Civil Fines/Non-Criminal Disposition contained in Chapter 17 LICENSING AND PERMITS GENERALLY and Chapter 20 CIVIL FINES/NON-CRIMINAL DISPOSITION CIVIL FINES to ensure they are in accordance with what is being charged and (2) review of the acceptance of G.L. c. 40 §22F, accepted on July 9, 2001, which allows certain municipal boards and officers to fix reasonable fees for the issuance of certain licenses, permits, or certificates.

REFERRED TO PROG & SERV, PUB. FAC., ZAP, AND FINANCE COMMITTEES

- #256-12 ALD. HESS-MAHAN, SANGIOLO & SWISTON proposing an ordinance promoting economic development and the mobile food truck industry in the City of Newton. [08/06/12 @4:46 PM]

REFERRED TO PROGRAMS & SERVICES AND FINANCE COMMITTEES

- #254-12(3) PROGRAMS & SERVICES COMMITTEE proposing an ordinance to require a fee, charged to consumers, for the use of paper bags at certain retail establishments in the City of Newton. [01/10/14 @ 3:36 pm]

#229-12 RECODIFICATION COMMITTEE recommending a review and possible amendment to the *Board of Aldermen Rules & Orders 2012-2013* relative to review of draft ordinances by the Law Department.

#145-12 ALD JOHNSON requesting a review by the Solicitor's office as to what constitutes "reorganization" per our City Charter. [05/16/12 @ 10:24PM]

REFERRED TO PROG & SERV AND PUBLIC FACILITIES COMMITTEES

#36-12 ALD. CROSSLEY & FULLER requesting Home Rule legislation or an ordinance to require inspections of private sewer lines and storm water drainage connections prior to settling a change in property ownership, to assure that private sewer lines are functioning properly and that there are no illegal storm water connections to the city sewer mains.

- A) Sewer lines found to be compromised or of inferior construction would have to be repaired or replaced as a condition of sale;
 - B) Illegal connections would have to be removed, corrected, and re-inspected in accordance with current city ordinances and codes, as a condition of sale.
- [01/24/12 @ 8:07 AM]

REFERRED TO PROG & SERV, PUB. FACIL. AND FINANCE COMMITTEES

#312-10 ALD. LENNON, LAPPIN, SCHNIPPER, SANGIOLO requesting a discussion with the School Committee on its plans to address space needs in the Newton public schools. [10/27/10 @ 11:07 AM]

Respectfully Submitted,

Amy Mah Sangiolo



Setti D. Warren
Mayor

City of Newton, Massachusetts
Department of Planning and Development
1000 Commonwealth Avenue Newton, Massachusetts 02459

Telephone
(617) 796-1120
Telefax
(617) 796-1142
TDD/TTY
(617) 796-1089
www.newtonma.gov

James Freas
Acting Director

Community Preservation Committee FUNDING RECOMMENDATION for Farlow Park Pond & Bridge

date: 18 August 2014
from: Community Preservation Committee
to: The Honorable Board of Aldermen

PROJECT GOALS & ELIGIBILITY

This project will restore the historic pond in Farlow Park and will construct a pedestrian bridge over the pond that honors the design of the park's rustic historic bridge, while meeting current accessibility standards. The project will also preserve the Underwood Elementary School's playing fields within the park by installing a new irrigation system. A new well will supply water for both the pond and the irrigation system.

The site's eligibility for CPA funding as a historic resource was established for two prior CPA appropriations: Board order 257-05 for a historic landscape report and Board order 193-08 for a pond feasibility study/water source exploration.

RECOMMENDED FUNDING

On 30 April 2014 the Community Preservation Committee voted 8-0 (member Dan Green absent) to recommend appropriating \$476,780 for this project to the control of the Commissioner of Parks & Recreation. On 5 August 2014, the CPC also voted 6-0 (members Mike Clarke and Tom Turner absent) to allow the release of CPA funds for design costs prior to the commitment of non-CPA funds required to complete the project.

Farlow Park Pond & Bridge - CPC Recommendation		
Uses	% of total	
* capital improvements (to be managed by Parks & Recreation Dept.), including:		
project management (Parks & Recreation Dept. staff time + funds for contracted manager)	\$61,600	10.1%
design & construction (total for pond & bridge)	\$520,780	85.0%
** operating reserve (minimum, to be held by Friends of Farlow Park)	\$30,000	4.9%
total	\$612,380	100.0%
Sources		
* CPA	\$476,780	77.9%
* City of Newton general budget (Parks & Recreation Dept. staff time)	\$5,600	0.9%
* CDBG	\$10,000	1.6%
* community sponsors (minimum, incl. \$1,000 from Newton Corner Neighborhood Association)	\$90,000	14.7%
additional non-CPA funds (community sponsors, CDBG, or other)	\$30,000	4.9%
total	\$612,380	100.0%
* As listed in November 2013 proposal to the CPC.		
** Neither CPA nor CDBG funds may be contributed to the operating reserve.		

website www.newtonma.gov/cpa

contact Alice E. Ingerson, Community Preservation Program Manager

email aingerson@newtonma.gov phone 617.796.1144

SPECIAL ISSUES CONSIDERED BY THE CPC

This recommendation is the culmination of a neighborhood aspiration expressed since at least the 1980s, and especially of prior funding proposals to the CPC initiated by the all-volunteer Friends of Farlow Park in 2004-05 (denied), 2005-06 (funded), 2006-07 (denied), and 2007-08 (funded). The CPC's unanimous support for the current proposal reflects the Friends' responsiveness to the two major needs the Committee has identified most consistently since 2005: for raising private funds and for ensuring future maintenance.

Project Phasing: At the CPC's urging, based on both aesthetic and project management concerns about deferring replacement of the current concrete-slab-and-chain-link "bridge," the Friends of Farlow Park added the design and construction of a new bridge to their original pre-proposal for restoring the pond.

Funding Leverage: Also in response to the CPC's concerns, the Friends of Farlow Park increased their commitment to community fundraising from \$1,000 in the pre-proposal to \$90,000 in the full proposal.

Stewardship: Based on both the history of Farlow Park and its appropriate, primary use – for passive recreation by neighborhood residents – the CPC has always been concerned that in the future, it may once again be difficult for this historic gem to compete for routine City funding with larger, more active recreation sites. As part of the current proposal, the City of Newton has committed to invest in maintaining Farlow Park the annual \$4,000 it anticipates saving by switching from MWRA water to well water for irrigating the Underwood School playing fields. In addition, the Friends of Farlow Park have now become a permanent 501(c)3 nonprofit, committed to holding at least \$30,000 of community donations in an "operating reserve" for the uses described in their 10 April 2014 submission to the CPC: "1. cost overruns [for the current project]; 2. future projects such as plantings and other ancillary needs such as new benches; and 3. emergency maintenance, if the Friends of Farlow Park determine the City of Newton has failed to fulfill its maintenance commitment" to Farlow Park.

ADDITIONAL RECOMMENDATIONS (*funding conditions*)

1. Funds for this project should be treated as 100% for historic resources and appropriated first from the Community Preservation Fund's historic resources fund balance and reserve, then from the general fund balance as needed.
2. CPA funds should be released for project design costs without condition. CPA funds should be released for construction only when all other funds in the budget on page 1 of this recommendation are committed.
3. Construction should begin within 6 months and be completed within 2 years after all funds in the budget on page 1 of this recommendation are committed, or by any extension of these deadlines granted in writing by the CPC in response to a request from the Commissioner of Parks & Recreation.
4. The Parks & Recreation Dept. should provide project updates upon request to the Friends of Farlow Park, the CPC and the Board of Aldermen; and prior to spending the final 10 percent of CPA funds, should present to the CPC an in-person and written final report, comparing budgeted-vs-actual expenditures.
5. Any CPA funds appropriated but not used for the purposes stated herein should be returned to the Newton Community Preservation Fund.

KEY OUTCOMES

The Community Preservation Committee will evaluate this project based on these key outcomes:

- Completion of construction within the budget shown on page 1 of this recommendation, and by the deadlines listed above.
- Historically appropriate maintenance of Farlow Park, with minimal use of the "operating reserve" held by the Friends of Farlow Park.

ATTACHMENTS (delivered to the clerks of the Programs & Services Committee and Finance Committee)

- Copy of CPC project webpage, listing all online information related to this proposal: <http://www.newtonma.gov/gov/planning/cpa/projects/farlow.asp>
- Proposal and supplemental submissions by the Parks & Recreation Dept. and Friends of Farlow Park
- Friends of Farlow Park slide presentation at the CPC's public hearing on this proposal
- All written community feedback received on this proposal



Links most relevant to August 2014
CPC funding recommendation
outlined in red.

Community Preservation Program

Farlow & Chaffin Parks

- location: 124 Vernon Street (bounded by Vernon, Eldredge & Church Streets)
Newton Corner, MA 02458
- funding: \$92,177 CPA funds appropriated to date (historic resources)
\$567,779 CPA funds requested (historic resources, recreation)
- phases: Each phase is documented below, in roughly reverse chronological order.
- 2004-06 [Historic Landscape Report](#)
 - 2007-14 [restoration & rehabilitation](#), including [pond feasibility study & design](#) (2007-12)
[pond construction, bridge design & construction](#) (2013-14)
- contacts: Commissioner of Parks & Recreation
124 Vernon Street
Newton Corner, MA 02458
email: bderubeis@newtonma.gov
phone: 617.796.1500
- Keith M. Jones
Friends of Farlow Park
109 Vernon St.
Newton Corner, MA 02458
email: keith.mjones@verizon.net
phone: 617.928.3343
- 1982-2006 historic character:
- [Farlow Park - Historic Significance](#)
(1982 National Register description and map of the park, 2004 Newton Historical Commission letter)
 - [Farlow & Kenrick Parks District, National Register of Historic Places](#)
(1982 - full district description, primarily focused on architecture) *This long file may load slowly.*
 - [Farlow & Chaffin Parks Historic Landscape Report](#) (2006) *This long file may load slowly.*

2005-14 [CPC votes & excerpted minutes for Farlow Park proposals](#)
 (from March 2005, on fall 2004 proposal, through August 2014, on fall 2013 proposal)

Farlow Park

Restoration and Rehabilitation

goals: Restore the ornamental pond in this historic park; design and construct a new, historically appropriate but fully accessible bridge to replace the current concrete-slab bridge; and install a new irrigation system to preserve the portion of the park used as a playing field by Underwood Elementary School. Construct a new well to supply water for both the pond and irrigation system.

funding:	\$40,000	CP funds appropriated & spent (historic resources) - pond feasibility study and design
	\$476,780	CPA funds requested & recommended (historic resources) - pond construction, bridge design and construction
	\$526,780	total CPA funds
	\$5,600	Parks & Recreation staff time for project management (City of Newton general budget)
	\$10,000	CDBG funds committed through annual action plan (submission to federal Dept. of Housing & Urban Development)
	\$90,000	to be raised from community sponsors (incl. \$30,000 operating reserve to be held by the Friends of Farlow Park; neither CDBG nor CPA funds can be contributed to this reserve)
	\$652,380	total project cost

Proposal Review & Appropriations

feasibility study & design (pond only)

- December 2007 [proposal](#)
[letters of support](#)
 See also [2004-05 letters for historic landscape report proposal](#).
- 23 January 2008 [presentation](#) at public hearing (includes photos & maps)
- 19 May 2008 [CPC funding recommendation](#)
- 14 July 2008 [Board order](#) (appropriation)

design & construction (construction only for pond, design & construction for bridge)

- 3 June 2013 [pre-proposal for pond construction](#), including map, photographs & draft budgets (updated versions below)

22 August 2013	<p>revised pre-proposal for pond & bridge (scope expanded by CPC request), including:</p> <ul style="list-style-type: none"> map, historic and current photographs draft budgets/cost estimates for: independent project manager, design and construction summary of pond specifications 2004-07 letters of support <i>Posted as a separate document.</i> historic significance (1982 National Register description and map of the park, 2004 Newton Historical Commission letter) <i>Posted as a separate document.</i>
13 November 2013- February 2014	<p>full proposal:</p> <ul style="list-style-type: none"> full proposal, including attachments for project budgets, City dept. budgets & letters attachments for: maps, photos, designs & specifications letters and petition of support (including additional letters and petition page submitted by sponsor January-February 2014) historic significance 1982 National Register description and map of the park, 2004 Newton Historical Commission letter) <i>Posted as a separate document.</i>
22 January 2014	slide presentation at CPC public hearing
March-April 2014	<p>additional information submitted, primarily at the request of the CPC:</p> <p>sponsor's nonprofit status & community fundraising plan; plus additional community letters (for 20 March 2014 CPC meeting)</p> <p>10-year operating budget, sponsor's nonprofit status & community fundraising plan; plus 2 additional community letters (for 30 April 2014 CPC meeting)</p>
18 August 2014	<p>CPC funding recommendation (originally voted 30 April 2014, one funding condition amended 5 August 2014)</p>

Project News

results of feasibility study & design (pond only)

15 July 2009	Exploratory drilling found water flow more than adequate for pond
February 2010	scope of work
June 2010	consultant presentation to community meeting <i>This long file may load slowly.</i>
16 March 2011	approved scope change : use of final remaining funds for a "well yield test" to determine if well proposed for filling a restored pond could also support a new, rezoned irrigation system for the school playground & field created on part of the original historic park; request approved by CPC
16 June 2011	consultant's draft final report: executive summary <i>This long file may load slowly.</i>
January 2012	consultant's final report: <i>These long files may load slowly.</i>

[summary specifications and cost estimates](#)

full report, [part 1](#) (plans)

full report, [part 2](#) (plans)

full report, [part 3](#) (specifications)

Farlow & Chaffin Parks Historic Landscape Report

goals: Hire a landscape preservation architect and structural engineer to create an overall landscape treatment plan for these historic parks, including historic and existing conditions report, engineering assessment of current bridge, and design analysis for possible reinstallation and maintenance of year-round pond.

funding:	\$52,177	CP funds appropriated (historic resources)
	\$1,292	unspent funds returned
	<hr/>	
	\$50,885	final project cost

Proposal Review & Appropriations

15 October 2004	main proposal , including the following attachments: appendix : plans, photos, historical research
October 2004- December 2005	letters of support , including multi-signature petition
29 June 2005	CPC funding recommendation
8 August 2005	Board order
June 2006	final Historic Landscape Restoration Report (large file, may load slowly) large-scale plan (11 x 17 inches)



Setti D. Warren
Mayor

**Newton, Massachusetts Community Preservation Program
FUNDING REQUEST**

PRE-PROPOSAL

PROPOSAL

(For staff use)
date rec'd:

3:30 pm,
13 November
2013

Form last updated April 2013.

For full instructions, see www.newtonma.gov/cpa or contact:

Community Preservation Program Manager,
City of Newton Planning & Development Department, 1000 Commonwealth Ave., Newton, MA 02459
aingerson@newtonma.gov 617.796.1144

You may adjust the space for each question, but the combined answers to all questions on this page must fit on this page.

Project TITLE	Farlow Park Restoration and Rehabilitation (Pond, Bridge and Irrigation)			
Project LOCATION	Full street address (with zip code), or other precise location. 129 Church Street, Newton, MA 02458			
Project CONTACTS	Name & title or organization	Email	Phone	Mailing address
Project Manager	Carol Schein, Open Space Coordinator	cschein@newtonma.gov	617-796-1500	Parks and Recreation 124 Vernon Street Newton, MA 02458
Other Contacts	Robert DeRubeis, Commissioner	brderubeis@newtonma.gov	617-796-1500	Parks and Recreation 124 Vernon Street Newton, MA 02458
Project FUNDING	CPA funds requested: \$476,780	Other funds to be used: \$105,600	Total project cost: \$582,380	
Project SUMMARY	Summarize the project's main tasks, components or features, and explain why it is eligible for CPA funds. You may provide more information in attachments, but your SUMMARY MUST FIT IN THE SPACE BELOW.			
<p>The Parks and Recreation Department along with its co-sponsor, the Friends of Farlow Park, is requesting Community Preservation Act funds to restore Farlow Park's primary character-defining features: its centrally located reflecting pond and the Adirondack-style bridge that spans it. Designed by George Meacham, designer of the Boston Public Garden, Farlow Park is listed on the National Register of Historic Places and falls under the CPA-definition of restoration of a historic resource. The scope of work is to include:</p> <p><u>Pre-Design Phase (3 months)</u></p> <ul style="list-style-type: none"> • The Friends of Farlow Park's architect develops and donates conceptual design of the bridge; • The Parks and Recreation Department procures an independent project manager to manage the project from start-up through project completion, with oversight by the Department project manager; and • The Parks and Recreation Department procures a structural engineering consultant. <p><u>Design and Bid Phase (4 months)</u></p> <ul style="list-style-type: none"> • Final design of a new bridge that complies with the Secretary of the Interior's Standards for the Treatment of Historic Properties, the Americans With Disabilities Act (ADA) and AASHTO's guidelines for pedestrian bridges; • Project coordination, in-house meetings and public hearings as needed; • Integration of the final bridge design package with the original Farlow 2008 bid package (restoration of the pond basin plus upgrade of the playground area's irrigation system); and • Coordination of bidding for the construction phase. <p><u>Construction Phase (4 months)</u></p> <ul style="list-style-type: none"> • Pre-construction meeting, weekly meetings and on-site meeting notes; • Coordination of shop drawing submittals/review and change orders; and • Regular sight visits to observe construction activity through project completion. <p>Rehabilitating the primary historic features of this cultural resource will reinforce its "sense of place," preserve Newton's unique character and create a place for all in the community to meet and enjoy now and for generations to come.</p>				

You may adjust the space for each question, but the combined answers to all questions on this page must fit on this page.

Project TITLE		Farlow Park Restoration and Rehabilitation (Pond, Bridge and Irrigation)				
USE of CPA FUNDS		HISTORIC RESOURCES	OPEN SPACE	or	RECREATION LAND	COMMUNITY Contact staff for separate form.
Check all that apply.	acquire					
	create	not allowed				
	preserve					
	rehabilitate/restore	X	Consult staff.			
COMMUNITY NEEDS	From at least 2 of the community-wide plans linked to <i>Guidelines & Forms</i> from www.newtonma.gov/cpa , provide the plan title, year, page number and a brief quote showing how this project meets needs already recognized in these plans. You may also list other community benefits not mentioned in any plan.					
<p><i>Newton Comprehensive Plan</i> (November 2007): “Identify historic places, both architectural and natural, that give the community its special character and that aid its future well-being.”</p> <p><i>Newton’s Heritage Landscapes</i> (May 2009), Page 8, <i>Building a 19th Century “Garden City”</i>: “Tree planting in village centers, creation of a garden cemetery, and picturesque landscaping of large estates set the City’s tone. Creation of Farlow Park and the Newton Centre Playground established a pattern of commitment to beautification.”</p> <p>draft <i>Open Space Plan 2013-2017</i>, Page 44: “Our open space and recreation vision is of being a metropolitan community able to maintain and preserve its natural assets and resources and able to meet both the passive and active recreational needs of its citizens. In such a vision, the well-being of Newton residents is promoted by policies that safeguard Newton’s land, air and water. Our parks, conservation areas and playgrounds can continue to provide opportunities for active and passive recreation through cooperative efforts—all ingredients of a vital community.”</p> <p>Page 56: “The remainder of Newton’s water bodies, although small, contribute to wildlife habitat, open space, and to Newton’s visual quality.”</p>						
COMMUNITY CONTACTS	List 3 Newton residents or organizations that can comment on the project and its manager’s qualifications. No more than 1 of these contacts should be a Board member, supervisor, employee or current work colleague of the project manager. Formal letters of support may also be attached but are not required.					
Name & title or organization	Email	Phone	Mailing address			
Keith Jones, Chair, Friends of Farlow Park	Keith.Mjones@Verizon.net	928-3343	109 Vernon Street Newton, MA 02458			
Jay Walter, Friends of Farlow Park	entasis@rcn.com	527-8383	83 Pembroke Newton MA 02458			
Andy Gluck, Friends of Farlow Park	Gluckers@aol.com	965-4097	19 Merton Street Newton MA 02458			
NON-CPA FUNDING	Source of funds		Amount requested	Date of funding decision (confirmed or expected)		
City of Newton CDBG funds recommended by Newton Corner Advisory Committee			\$10,000	Confirmed		
Newton Corner Neighborhood Association			\$1,000	Confirmed		
Parks and Recreation Dept. Project Management			\$5,600	Confirmed		
Community Sponsors			\$89,000	Expected		

You may adjust the space for each question, but the combined answers to all questions on this page must fit on this page.
Especially for pre-proposals, use only as many lines as needed to give a broad overview of your project.
 Full proposals must also include a full, detailed budget in addition to this page.

Project TITLE	Farlow Park Restoration and Rehabilitation (Pond, Bridge and Irrigation)		
Project BUDGET	USES of Funds (major expense categories)		SOURCES of Funds (CPA & others)
CAPITAL/DEVELOPMENT COSTS			
<i>See back-up for detailed cost information</i>			
Project Management – start-up through final completion	\$61,600	CPA	\$476,780
New bridge design and construction	\$238,620	CDBG	\$10,000
Pond basin & irrigation system construct.	\$282,160	Newton Corner Neighborhood Assoc.	\$ 1,000
		Community Sponsors	\$89,000
		Parks and Recreation Dept. (Proj. Mgr.)	\$5,600
TOTAL	\$582,380		TOTAL \$582,380
ANNUAL OPERATIONS & MAINTENANCE (cannot use CPA funds)			
Electricity	\$690	City general fund budget	\$ 690
Bridge	--	TBD, but final design is to be low-maintenance	--
TOTAL	\$ 690		TOTAL \$ 690
Project TIMELINE	Phase or Task	Notes (required fundraising, permits, bidding, etc.)	Season & Year
Construction documents are in hand for the pond, well, and irrigation system from previous phase. Refer to http://www.newtonma.gov/gov/planning/cpa/projects/farlow.asp			
	RFP/contract with independent project manager		Spring 2014
	RFP/contract with PE firm to: design bridge, develop final construction documents and incorporate with pond construction documents and manage bid and Construction phases		Spring 2014
	Four-month bridge design/bid phase		Summer 2014
	Three-month construction phase for bridge, pond and irrigation		Spring 2015

Farlow Park Restoration and Rehabilitation (Pond, Bridge and Irrigation)
November 15, 2013

Project Summary Costs

<u>Item Description</u>	<u>Cost</u>
Independent Project Manager	\$56,000 (soft cost)
Parks and Recreation Project Manager	<u>\$5,600</u> (soft cost)
Project Management subtotal:	\$61,600 (subtotal)
Bridge Design	\$49,195 (soft cost)
Bridge Construction	<u>\$189,425</u> (hard cost)
Bridge Design and Construction subtotal:	\$238,620 (subtotal)
Pond Basin Restoration and New Irrigation System subtotal:	<u>\$282,160</u> (hard cost)
Total Project:	<u>\$582,380</u>

Farlow Park Bridge Restoration Cost Estimate - Design and Construction

Item Description	2006 Estimate	2013 Updated Estimate (3% inflation/year)	Subtotal	TOTAL
(from Amman and Whitney 2006 Master Plan)				
<u>Design (soft costs)</u>				
Schematic Design	\$ 7,000	\$ 8,609		
Preliminary Design	\$ 12,000	\$ 14,758		
Contract Bid Documents	\$ 21,000	\$ 25,827		
			\$ 49,195	
<u>Bridge Construction (hard Costs)</u>				
Bridge Removal		\$ 20,000		
Sub-surface exploration	\$ 4,000	\$ 6,000		
Precast Concrete Rigid Frame with Stone Veneer	\$ 128,000	\$ 157,424		
Additional Railing for 2013 Bridge Design		\$ 6,000		
			\$ 189,424	
Total Bridge Design and Construction Cost				<u>\$ 238,619</u>

Farlow Park Pond Basin Restoration and New Irrigation System
Cost Estimate

Item Description	unit	quantity	unit price	total	subtotal	total (2011)	total (2013)
(from Weston & Sampson 2011)							
General Conditions							
General conditions	allw	0.08	\$ 255,935	\$ 20,475			
Tree protection	EA	17	\$ 200	\$ 3,400			
					\$ 23,875		
Demolition/Site Preparation							
earth fill removal in concrete pool liner	CY	780	\$ 45	\$ 35,100			
					\$ 35,100		
Drainage Structures/Infrastructure							
New catch basin	EA	1	\$ 4,500	\$ 4,500			
Overflow inlet at pond edge	EA	1	\$ 2,500	\$ 2,500			
New manhole	EA	1	\$ 4,500	\$ 4,500			
Frame and Cover	EA	1	\$ 560	\$ 560			
Frame and Grate	EA	1	\$ 600	\$ 600			
Drainage gate valve	EA	1	\$ 1,500	\$ 1,500			
Drainage pipe	LF	125	\$ 50	\$ 6,250			
					\$ 20,410		
Utility Services/Mechanical Equip.							
Electrial service connection/cabinet	LF	1	\$ 9,000	\$ 9,000			
(1) well pump (1) aerator (1) water level	LS	1	\$ 25,000	\$ 25,000			
New irrigation system	LS	1	\$ 35,000	\$ 35,000			
30' of pipe from pump to pond	LF	30	\$ 50	\$ 1,500			
					\$ 70,500		
General Site Improvements							
Loam & seed of disturbed areas	LS	1	\$ 15,000	\$ 15,000			
					\$ 15,000		
Concrete Restoration-Pond							
Concrete Partial Depth Repair	SF	450	\$ 20	\$ 9,000			
Concrete Full Depth	SF	250	\$ 30	\$ 7,500			
Crack Repair--routing and Sealing	SF	280	\$ 20	\$ 5,600			
Crack Repair-Gravity Filling	LF	280	\$ 35	\$ 9,800			
Crack Repair-Polyurethane Injection	LF	200	\$ 150	\$ 30,000			
Epoxy Pond Liner System	LS	1	\$ 15,000	\$ 15,000			
					\$ 76,900		
Subtotal						\$241,785	
Contingency (@ 10%)						\$ 24,178	
Total for Farlow Park Pond Basin Restoration and New Irrigation System						\$265,963	\$282,160

Additional Farlow Park 10-Year Maintenance Costs
Related to Proposed Pedestrian Bridge and Reflecting Pond Only

April 2, 2014

A. PEDESTRIAN BRIDGE

Description	Hours Over 10 Years	Hourly Rate	Subtotal	Total Cost Over 10 Years
structural check (2 hrs per year)	20	\$ 25	\$ 500	\$ 500
repaint/touch up railings (3 days over 10 years)	24	\$ 25	\$ 600	\$ 600
graffitti removal (2 days over 10 years)	16	\$ 25	\$ 400	\$ 400
repair brick paver bridge surface* (.5 day every other year)	40	\$ 25	\$ 1,000	\$ 1,000
Total Cost to Maintain Bridge over 10 Years:				\$ 2,500

B. REFLECTING POND

Description	Hours over 10 years	Hourly Rate	Subtotal	Total Cost Over 10 Years
<i>assumes pond water-filled April - Oct. season [28 wks]</i>				
spring check: drain/repair/clean basin & edge: 1 day per year	80	\$ 25	\$ 2,000	\$ 2,000
clear leaves/trash/debris from water (1 hr/week every other week)	140	\$ 25	\$ 3,500	\$ 3,500
<i>assumes ice-filled December-February (12 weeks)</i>				
drain system/fill and prepare for skating season (.5 day per year)	40	\$ 25	\$ 1,000	\$ 1,000
check system/weatherize (2 hrs/yr)	20	\$ 25	\$ 500	\$ 500
spray/smooth ice for winter skating (1 hr/wk for 12 weeks)	120	\$ 25	\$ 3,000	\$ 3,000
subtotal:				\$ 10,000

Labor and Materials - Pond Replacement Parts as Needed	Quantity over 10 Years	Unit Cost	Subtotal	Total Cost Over 10 Years
Replace aeration device	1	\$ 250	\$ 250	\$ 250
Replace pump	1	\$ 10,500	\$ 10,500	\$ 10,500
Replace water level sensor	1	\$ 75	\$ 75	\$ 75
subtotal:				\$ 10,825

Total Cost to Maintain Reflecting Pond over 10 Years: \$ 20,825

Utilities	Years	Unit Cost	Subtotal	Total Cost Over 10 Years
Electric cost to run well pump	10	\$ 690	\$ 6,900	\$ 6,900

Total Cost to Maintain Reflecting Pond and Bridge over 10 Years: \$ 30,225



NEWTON PARKS AND RECREATION DEPARTMENT

124 Vernon Street, Newton, MA 02458
Office: (617) 796-1500
Fax: (617) 796-1512



SETTI D. WARREN
MAYOR

ROBERT J. DERUBEIS
COMMISSIONER

April 11, 2014

Joel Feinberg, Chair
Community Preservation Committee
1000 Commonwealth Avenue
Newton, MA 02459

Dear Chairman Fineberg and Community Preservation Committee Members,

I am writing with respect to the Farlow Park Restoration and Rehabilitation. A concern that has been brought up during working sessions are the maintenance costs associated with the project. Farlow Park is a site that is currently maintained by Parks & Recreation. Inclusive in that maintenance cost is general litter pick-up, grass cutting and leaf removal.

With the proposed pedestrian bridge and reflecting pond, we have identified some additional maintenance issues that will warrant our attention. Based on departmental calculations, these costs would be in the vicinity of \$2,800 to \$3,000 per year on average. Some of the maintenance items identified are currently being addressed and the new ones can be absorbed by the department. As the Commissioner, I am confident that realizing the aforementioned costs is one that the department can handle and we are comfortable maintaining this site.

I would ask that you act favorably upon this project and support it through to completion.

Sincerely,

Robert J. DeRubeis
Commissioner

Cc: Alice E. Ingerson, Ph.D., Community Preservation Program Manager
Carol Schein, Open Space Coordinator
Keith Jones, Chair, Friends of Farlow Park

COMMISSION
MEMBERS

WARD 1 - BETHEL CHARKOUDIAN
WARD 2 - ARTHUR MAGNI, CHAIRMAN
WARD 3 - PETER JOHNSON

WARD 4 - FRANCIS J. RICE
WARD 5 - WALTER S. BERNHEIMER II,
WARD 6 - ANDREW STERN

WARD 7 - RICHARD TUCKER
WARD 8 - KATHLEEN A HEITMAN, VICE- CHAIRMAN
ROBIN MCLAUGHLIN - COMM. SECRETARY

ALTERNATES: MICHAEL CLARKE, PETER KASTNER, JACK NEVILLE, DONALD FISHMAN

WWW.CI.NEWTON.MA.US/PARKS



SETTI D. WARREN
MAYOR

City of Newton, Massachusetts
Office of the Mayor

Telephone
(617) 796-1100

Telefax
(617) 796-1113

TDD
(617) 796-1089

E-mail
swarren@newtonma.gov

April 9, 2014

Joel Feinberg, Chair
Community Preservation Committee
1000 Commonwealth Avenue
Newton, MA 02459

RE: Farlow Park Proposal for CPA Funding

Dear Chairman Feinberg and Members of the CPC,
I am writing regarding a project proposal before you, the Farlow Park Restoration. As you're aware, this project restores the original historical attributes of the park, to include a pond and a new footbridge. The proposal to irrigate the site and provide water for the pond is through activating an existing well that provides adequate flow, requiring only the addition of a pump.

Currently, irrigation water for the fields is provided from the Underwood School, an operation that incurs not only water costs as billed by the prevailing rates, but also sewage costs, despite the fact that this irrigation water only, as there is no means to isolate the usage. While the annual cost can only be estimated based on the length of time and area of land irrigated, but such usage typically costs thousands of dollars per year. This water cost could be all but mitigated by converting to well usage, except there will be new costs for electricity which is normally in the range of a few hundred dollars per year.

It is anticipated that there will be increased maintenance costs for the park after build out, however it is projected that such costs will be less than savings from the conversion of the irrigation source, or most conservatively, at least revenue neutral. As the City budget is derived with an "outcome-based approach" (not a dollar-for-dollar transfer), should this park project move forward and be developed, the City would support the increased maintenance costs through the Parks & Recreation Department's budget, anticipating that savings are realized in another department's budget.

I hope this helps in your deliberations as to the funding of this worthy project. Should you have further financial questions regarding this project, feel free to contact Maureen Lemieux, the Chief Financial Officer at 617-796-1100.

Sincerely,

Robert R. Rooney
Chief Operating Officer

Cc: Scott Lennon, President of the Board and Ward 1 Alderman
Maureen Lemieux, Chief of Staff and Chief Financial Officer
Bob DeRubeis, Parks and Recreation Commissioner



SETTI D. WARREN
MAYOR

NEWTON PARKS AND RECREATION DEPARTMENT

124 Vernon St, Newton, MA 02458
Office: (617) 796-1500/Fax: (617) 796-1512
TDD/TTY: (617) 796-1089
parks@newtonma.gov



ROBERT J. DERUBEIS
COMMISSIONER

October 23, 2013

Alice E. Ingerson, Ph.D.
Community Preservation Program Manager
Newton Planning & Development Department
City Hall, 1000 Commonwealth Ave.
Newton, MA 02459

Dear Ms. Ingerson:

This letter is to confirm the motion made by the Parks & Recreation Commission on September 16, 2013 regarding the Farlow Park – Pond & Bridge proposal.

On **June 20, 2011** the Commission approved the Farlow Park pond portion of this proposal. Mr. Keith Jones appeared before the Commission on September 16, 2013 to present the addition of the bridge to the project. The following motion was made and approved by the Parks & Recreation Commission:

*Mr. Fishman made the motion that the P & R Commission recommends the Farlow Park project with its combined bridge and pond be moved to the next level. Ms. Charkoudian seconded the motion.
Motion passed 8-0*

If you have any questions, please call the Parks & Recreation Office at 617.796.1500.

Sincerely,

Robert J. DeRubeis
Parks & Recreation Commissioner



Setti D. Warren
Mayor

City of Newton, Massachusetts
Department of Planning and Development
1000 Commonwealth Avenue Newton, Massachusetts 02459

Telephone
(617) 796-1120
Telefax
(617) 796-1142
TDD/TTY
(617) 796-1089
www.newtonma.gov

Candace Havens
Director

RECORD OF ACTION:

DATE:

November 6, 2013

SUBJECT:

Farlow Park Pond Restoration and Bridge Replacement

At a scheduled meeting and public hearing on October 24, 2013 the Newton Historical Commission, by vote of 7-0,

RESOLVED to approve the proposed changes at Farlow Park under the provisions of the City-Owned Properties ordinance with the following conditions: (1) that the proposed railing design with cross-buck pattern more closely resemble the original; and (2) that the final plans be reviewed and approved by staff prior to issuance of a building permit. **FURTHER RESOLVED** that the Commission recommends that the historic pathways be restored as shown on the plans for the park's construction.

Voting in the Affirmative:

Donald Lang, Chair
David Morton, Member
Nancy Grissom, Member
Rodney Barker, Member
Mark Armstrong, Member
Jean Fulkerson, Member
Laura Fitzmaurice, Alternate

Not Voting:

Ellen Klapper, Alternate

Brian Lever, Commission Staff



CITY OF NEWTON, MASSACHUSETTS
 Department of Planning and Development
 Michael J. Kruse, Director

Telephone
 (617)-796-1120
 Telefax
 (617) 796-1142

David B. Cohen
 Mayor

November 22, 2004

Community Preservation Committee
 c/o Planning and Development Department
 1000 Commonwealth Avenue
 Newton, MA 02459

RE: Farlow Park and Chaffin Park Restoration Project

Dear Community Preservation Committee Members:

The Newton Historical Commission would like to express its strong support for the Friends of Farlow Park and the Parks and Recreation Department's grant application to complete a study which will provide plans for the preservation and restoration of Newton Corner's Farlow and Chaffin Parks. Both parks are historically and architecturally significant for their association with numerous prominent Newton citizens, with the development of the City's early recreation facilities, and with the development of their Newton Corner neighborhood. Both are also listed on the National Register as contributing properties within the Farlow and Kenrick Parks National Register District.

As the City's first park, and the only City park known to be associated with prominent 19th century architect George Frederick Meacham, designer of the Boston Public Gardens, Farlow Park holds a unique place in the history of the City's recreational spaces and the development of Newton Corner. Completed in 1888 on land donated by local philanthropist John Farlow, this was the first space in the City to be designed purely for the recreation and enjoyment of the surrounding residential neighborhood. While later alterations and the removal of the central pond and Victorian style bridge have impacted the park's original scheme, its general design and gently curving pathways are still readily apparent. In the same respect, as a surviving portion of the original Chaffin estate, Chaffin Park has close ties to the development of Newton Corner and while altered, has retained a close association with the estate's ca. 1845 Greek Revival style mansion, now the Newton Corner Branch Library. However, it too has lost several of its most notable original features. The proposed study will be an important first step in the preservation of the site's existing historic resources and the restoration of their lost design elements.

The Farlow and Chaffin Parks are unique neighborhood landscapes which have retained their historic setting, layout, and use. Their restoration will make a significant impact on the integrity of these historic City resources and the Newton Historical Commission hopes that you will look favorably upon this grant application.

Sincerely,

John S. Rodman, Chairman
 Newton Historical Commission

Newton Historical Commission
 1000 Commonwealth Avenue, Newton, Massachusetts 02459
 Email: lkritzer@ci.newton.ma.us
 www.ci.newton.ma.us

From: "Joel Reider" <jreider@newtonma.gov>
To: cschein@newtonma.gov
Date sent: Tue, 24 Sep 2013 16:25:02 -0400
Subject: Re: Farlow Park Bridge Design
Priority: normal

Hi Carol,

Only if applying for a variance from accessibility regulations are you required to submit plans for review by COD or MAAB. As long as the plans comply with MAAB and ADA (you say the new bridge will be accessible), they do not have to be reviewed.

Joel

Joel Reider
ADA/Section 504 Accessibility Coordinator,
City of Newton
1000 Commonwealth Avenue
Newton, Massachusetts 02459
617 796-1145
jreider@newtonma.gov

PLEASE NOTE: Newton's ADA Coordinator is a part-time position. I am in the office all day Monday and Tuesday and also Thursday morning. I will respond to email as quickly as I can.

> Joel,
> I am the Project Manager for a historic park restoration project in
> Newton Corner that is applying for Community Preservation Act (CPA)
> funding this November. The project, entitled "Restoration of Farlow
> Park Bridge and Pond" involves removing an old inaccessible pedestrian
> bridge and replacing it with a new accessible bridge (including ramps
> and railings) designed to be in keeping with the look of the park's
> original Adirondack-style bridge. The Parks and Recreation Department
> and the Friends of Farlow Park (cc'd here) are co-sponsors.
>
> While there is only a conceptual design for the bridge at this time, the
> Community Preservation Committee (CPC) has asked that we check whether
> or not the project needs to go before Newton's Commission on Disability
> and/or the Massachusetts Architectural Access Board. I am attaching
> here (1) a photo that shows the bridge as it exists today; (2) the
> conceptual design for the new bridge; and (3) the master plan for the
> park so you can see where it fits into the whole scheme.
>
> Please let me know if you think it will require review, and if so, at
> what time in the design process would be best. Thank you. --Carol
Carol Schein, Open Space Coordinator
Newton Parks and Recreation
124 Vernon Street Newton, MA 02458
617-796-1507

Location of Farlow Park



Images of Farlow Park Pond and Bridge, ca. 1900-1930



Original plan for Farlow Park, 1885

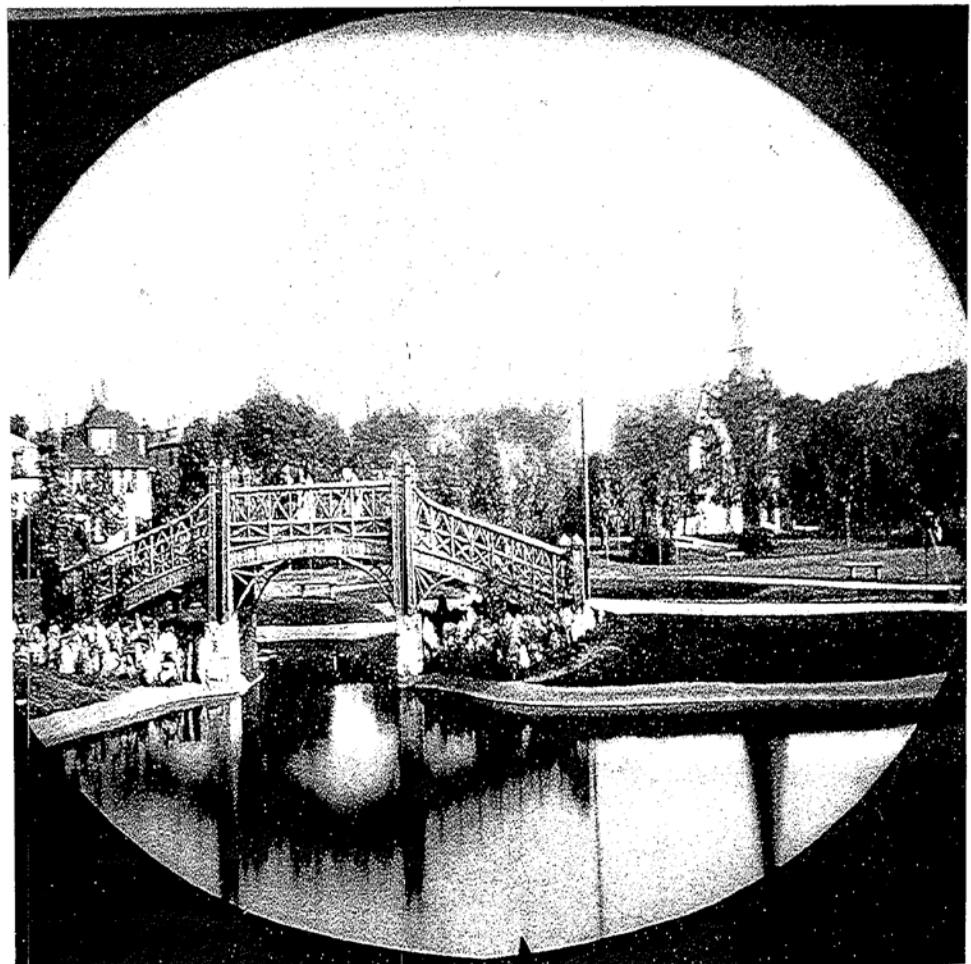
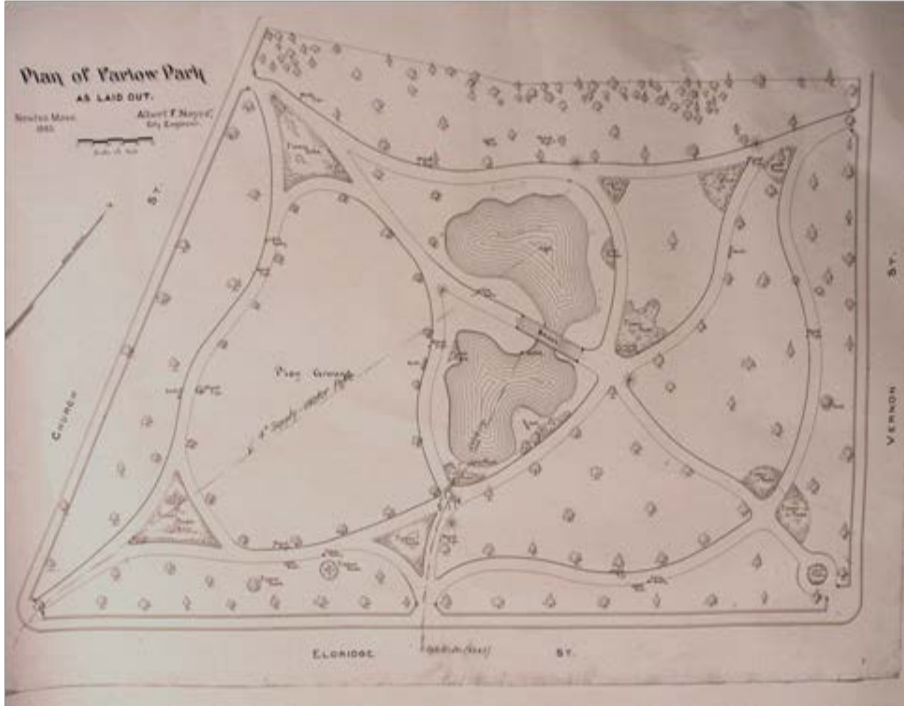

Farlow Park, Newton Corner, is seen here in 1888, shortly after the landscaping had been completed.

Farlow Park in 1888



Farlow Park
in the 1880s



Farlow Park
pond & bridge

in 2007 (at left)

during 2010
exploration of pond
basin condition &
drilling for potential
pond water supply
(below)



National Register of Historic Places

State Historic Sites

Historic Districts

Travel Sites

Vacant/Not in Use

MASSACHUSETTS - Middlesex County

Farlow and Kendrick Parks Historic District (added 1982 - District - #82002745)

Also known as **See Also: Farlow and Kendrick Parks Historic District (Bounda**

Roughly bounded by Franklin, Park, Church, Center and Wesley Sts. and Maple Ave., Newton

Historic Significance: Architecture/Engineering

Architect, builder, or engineer: Multiple

Architectural Style: Greek Revival, Late Victorian, Colonial Revival

Area of Significance: Architecture, Landscape Architecture

Period of Significance: 1800-1824, 1825-1849, 1850-1874, 1875-1899, 1900-1924

Owner: Local Gov't, Private

Historic Function: Domestic, Landscape, Religion

Historic Sub-function: Park, Religious Structure, Single Dwelling

Current Function: Domestic, Landscape, Religion

Current Sub-function: Park, Religious Structure, Single Dwelling

Farlow and Kendrick Parks Historic District (Boundary Increase) (added 1986 - District - #86001739)

Also known as **See Also: Farlow and Kendrick Parks Historic District 223, 226, 234, 237, 242, 243, 248, and 256 Park St., Newton**

Historic Significance: Architecture/Engineering, Event

Architect, builder, or engineer: Unknown

Architectural Style: Greek Revival, Late Victorian, Colonial Revival

Area of Significance: Social History, Architecture

Period of Significance: 1825-1849, 1850-1874, 1875-1899

Owner: Private

Historic Function: Domestic

Historic Sub-function: Single Dwelling

Current Function: Domestic

Current Sub-function: Single Dwelling

Farmer, Kimball, House (added 1985 - Building - #85001031) 1173 Massachusetts Ave., Arlington

Historic Significance: Architecture/Engineering

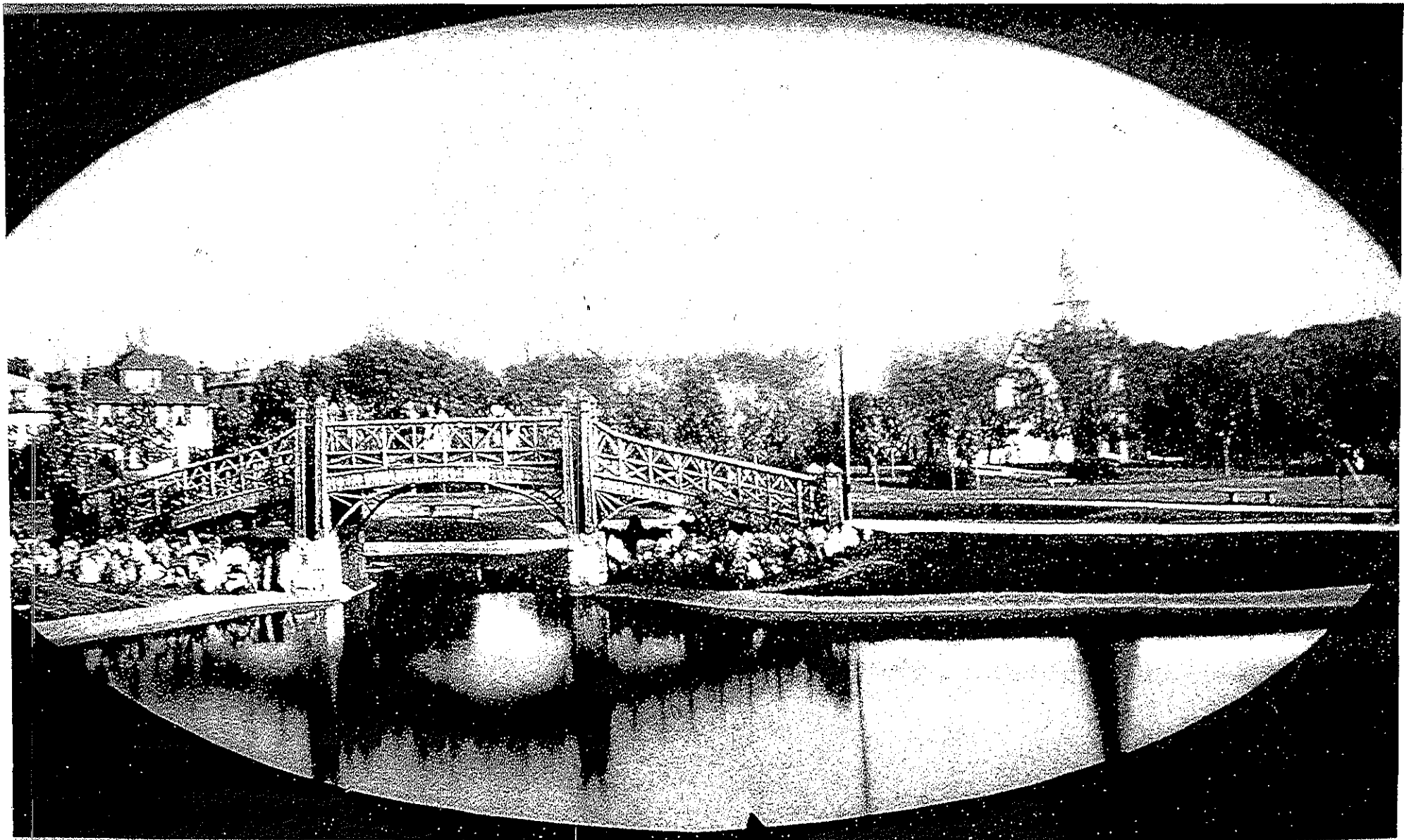

ow Park, Newton Corner, is seen here in 1888, shortly after the landscaping had be
pleted.

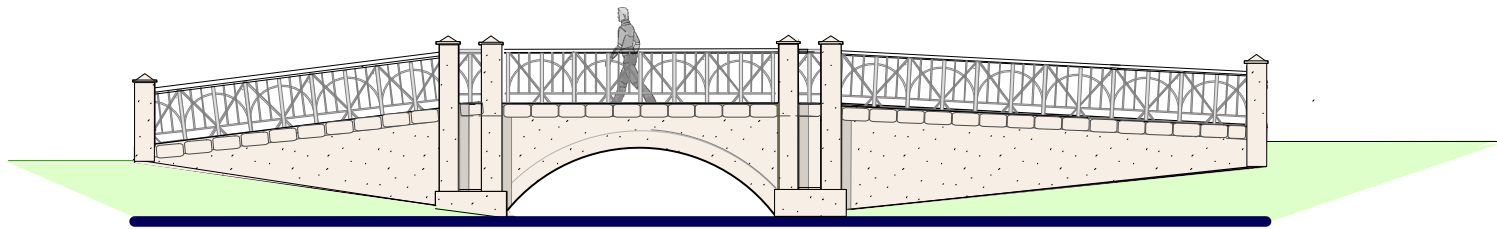

Bridge Elevation

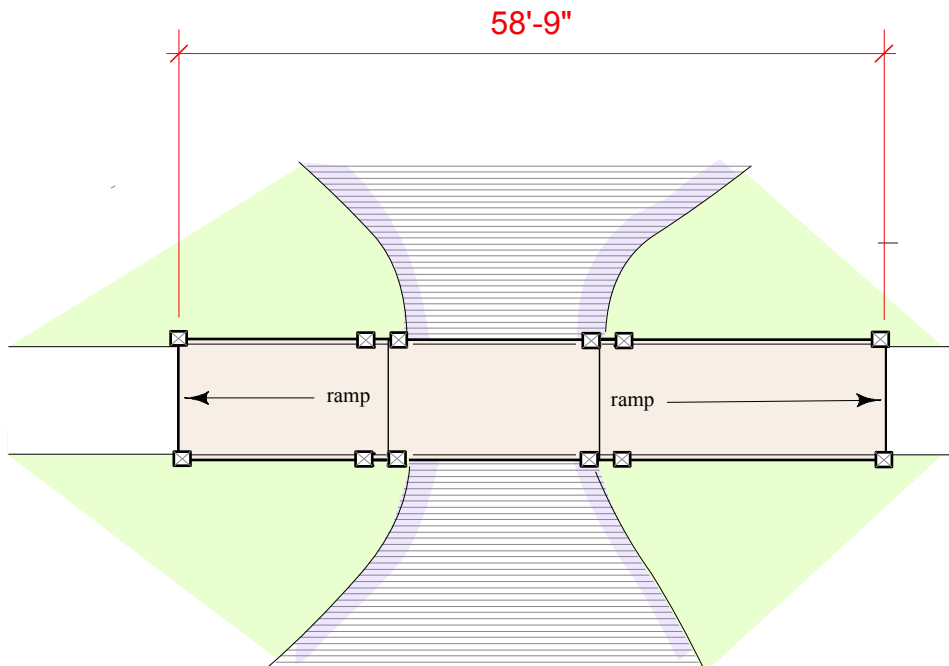

Bridge Plan

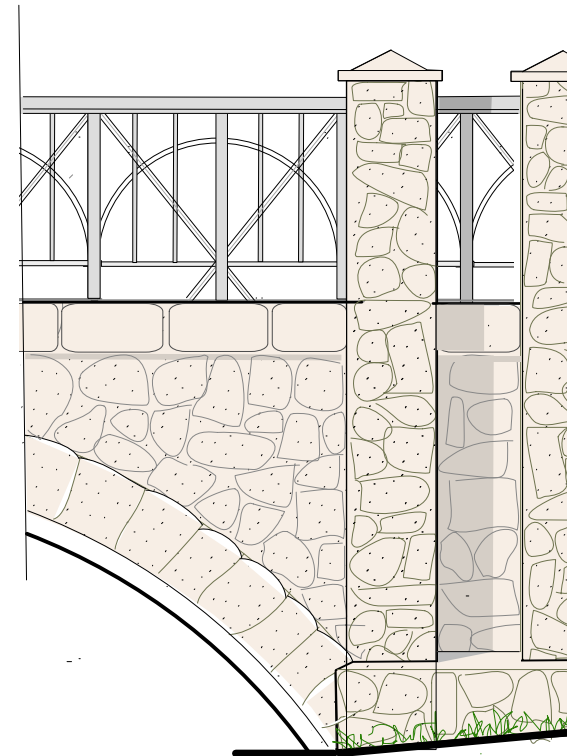

Detail

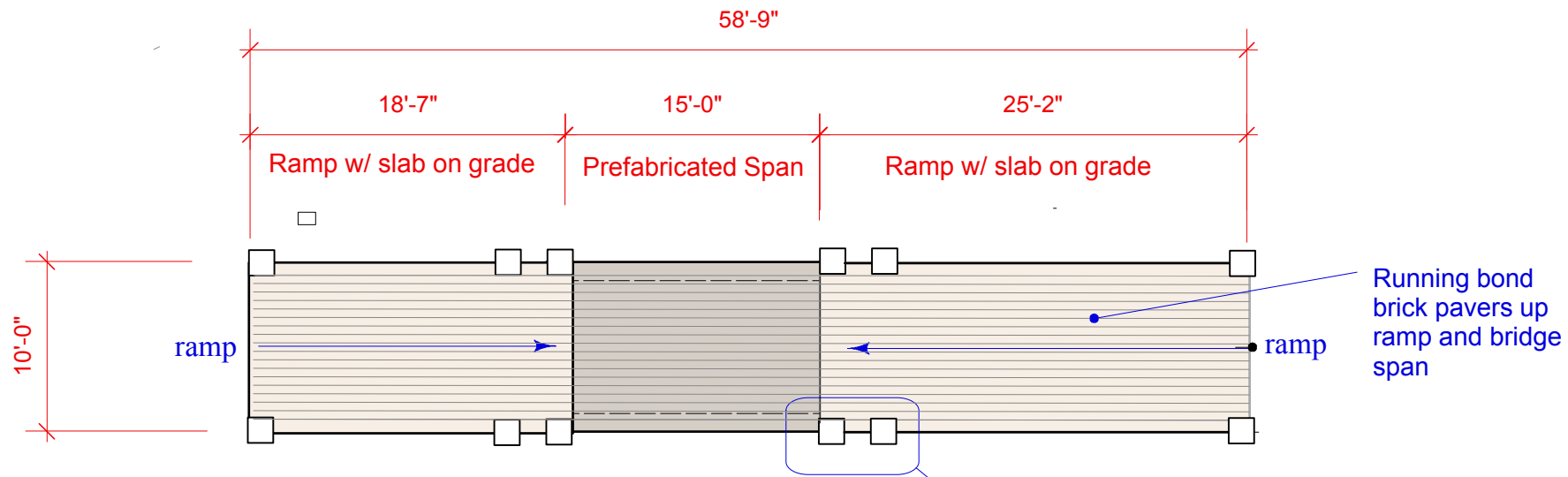

Bridge Plan

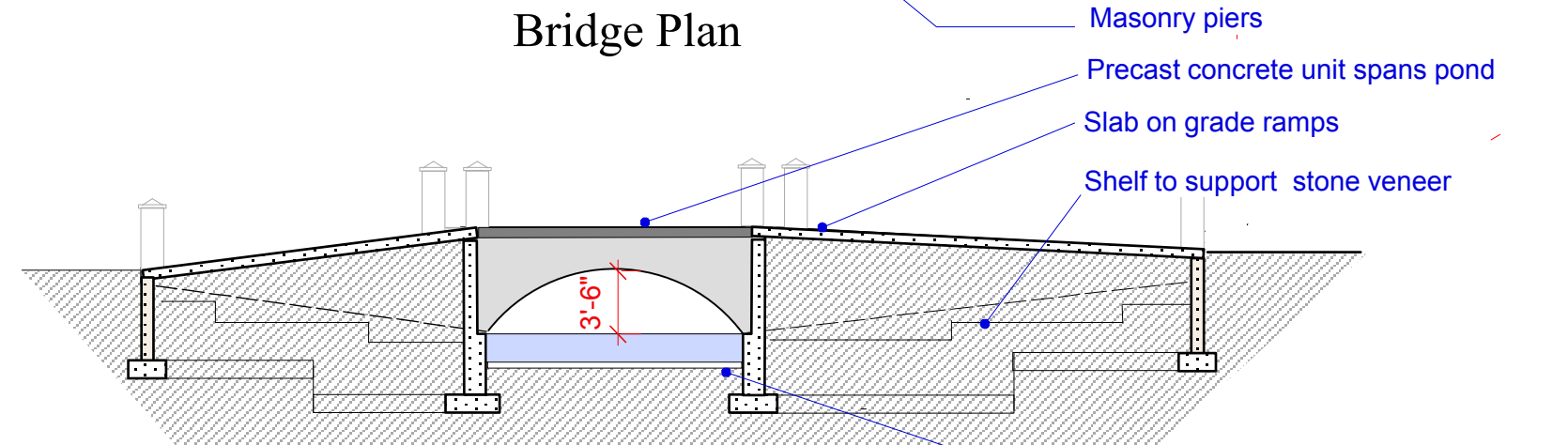

Bridge Longitudinal Section

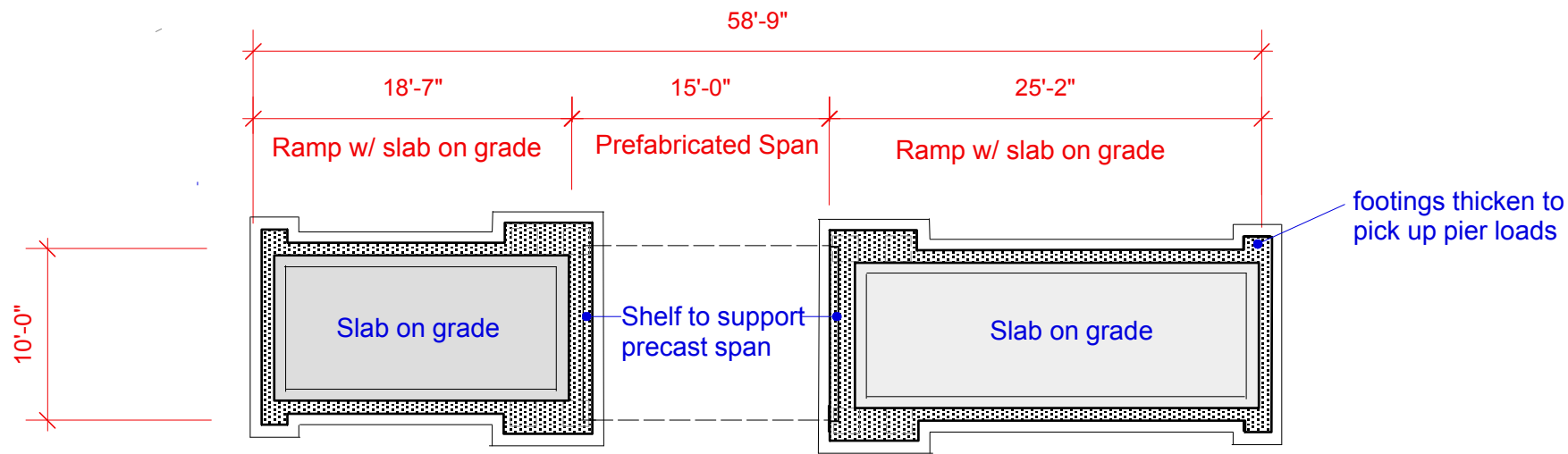

Foundation Plan

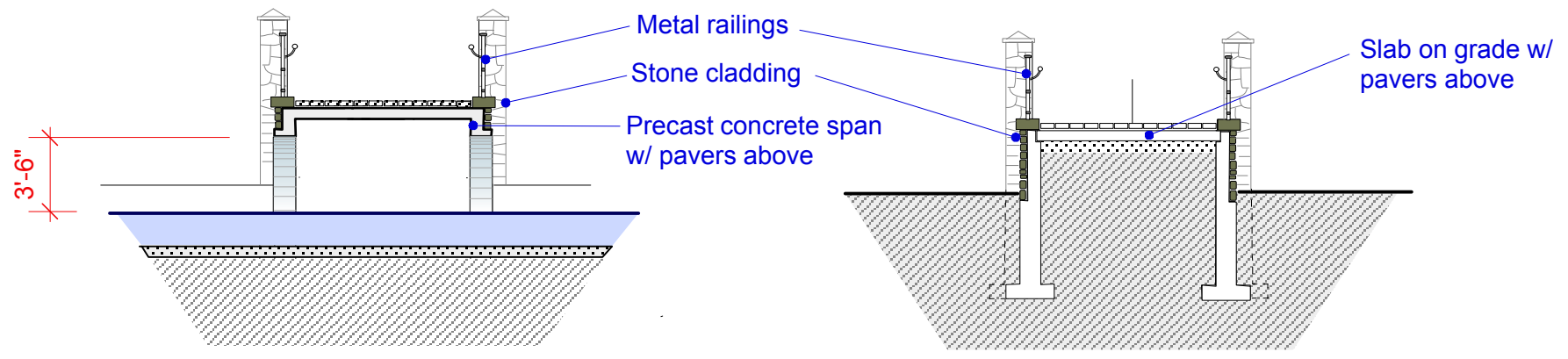

Section at Precast Span

Section at Ramp

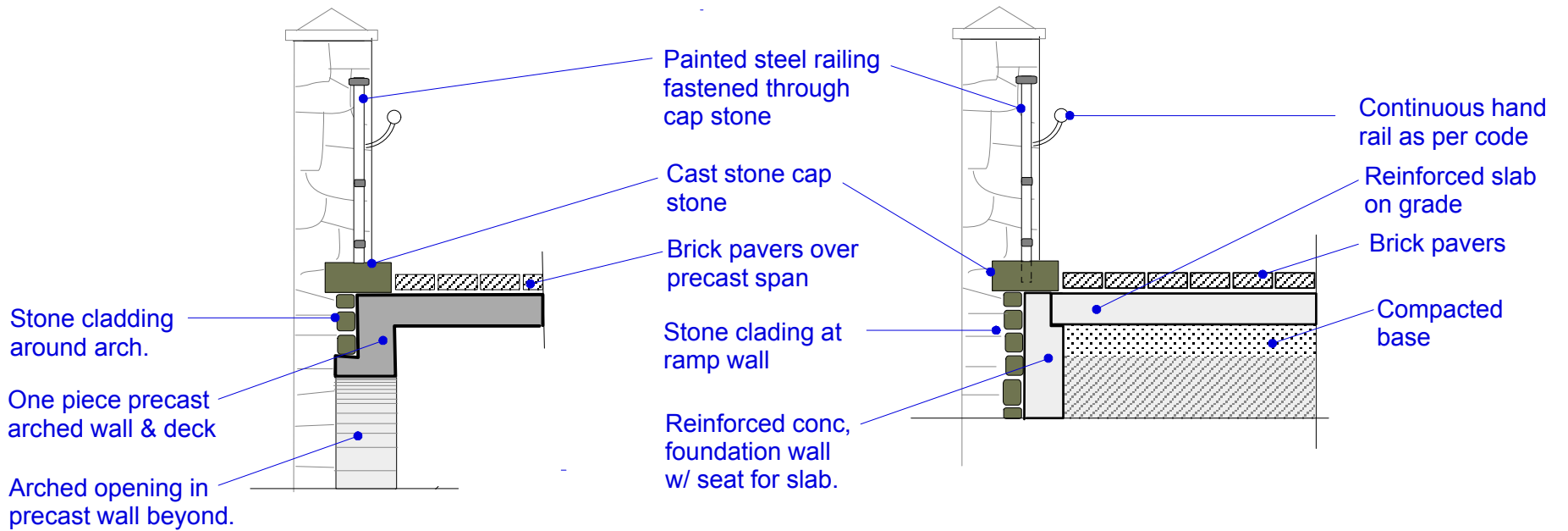

Section at Precast Span

Section at ramp wall

Performance Specification
Farlow Park Pond Irrigation and Pond Water Supply Project

General: The purpose of the project is to install a new submersible well pump maximum 5 horsepower, capable for pumping 25 gallons per minute at 50 psi to the irrigation system. The new well pump will be set approximately 350 feet deep in the existing Farlow Pond Well.

The following items will be provided:

One well pump:

- 5 Horsepower, 208 volt 3 phase motor sized for VFD Service
- 304 stainless steel well pump
- 25 gpm at 415 feet TDH

Well level sensor

- Shall de-energize pump motor if water inside well casing drops to 10 feet above well pump assembly. Provide 1 inch conduit to Well Controller with instrumentation wiring.

Drop Pipe and Pitless Adapter

Provide 2 inch Drop Pipe and 2 inch pitless adaptor. Provide two ¾ inch pipes, two ¾ inch valves and valve boxes and 2 inch isolation gate and valve box with t wrench extension to ground surface to allow use of air to winterize well drop pipe and 2 inch pipe to irrigation system.

Pipe to Irrigation System

Install 2 inch pipe from Well to Irrigation system (located adjacent to Pump Control Cabinets). Materials and methods to comply with Specification 02810.

Variable Speed Control

- Provide variable speed pump controller to convert single phase supply power to 3 phase power supply for new well pump. Provide lightning protection for VFD. VFD Fail status shall energize external alarm light.

PLC Controller

- Provide PLC based controller to:
 - Energize de energize well pump
 - Shut down well pump based on well drawdown
 - Shut down pump based on loss of water pressure (20 psi initial set point)
 - Provide control signal to well VFD to supply constant pressure to Irrigation system (initial set point 50 psi).

To energize irrigation system when called for by time clock (provide field adjustable setting for irrigation time clock) and allowed by time clock, temperature sensor (initial well pump lock out setting of 40 F) and rain sensor gauge.

Control solenoid valve to irrigation system

Energize well pump to fill Farlow Pond when called for by low pond level sensor and to de energize the well pump when high level sensor is energized.

Irrigation setting shall take precedence over pond filling function.

Control solenoid valve for well water flow to Farlow Pond. Provide backpressure valve if required for proper well pump VFD operation.

Pump or system fail shall energize external alarm light.

PLC supplier shall coordinate with well pump start signals from the irrigation system controller.

Pond Level Sensors

Provide two water level sensors for high and low level water sensing in pond. Provide low voltage wiring to PLC Controller. General Contractor to provide stainless steel pipe anchored to pond bottom and bridge to attach the pond level sensors.

VFD and PLC Cabinets

Provide separate 304 stainless steel cabinets for VFD and PLC controller. Provide external heat sink and fan for cooling VFD and PLC. Provide lockable cabinets with yellow alarm light on top of each cabinet. Provide custom engraved sign with instructions for department to call in event of alarm. Provide special isolated ground grid for VFD and PLC. Provide lightning protection for VFD/PLC Cabinets. Provide shop drawings for internal wiring of VFD/PLC Cabinet.

Irrigation System Control and Cabinet

The irrigation control system provided by Specification Section 02810 will require a 20 amp single phase power connection. All other wiring, zone valves and controls associated with the irrigation will be provided by Section 02810. The Irrigation Contractor shall be responsible for integrating well pump start signals with the Well Pump VFD PLC.

Irrigation Cabinet shall be located adjacent to Well Pump VFD and PLC Cabinets.

Commissioning, Training and Operation and Maintenance Manuals

After irrigation and pond filing system has been started up and operating without failure for 5 days, provide 4 hours on site training for OWNER's staff. Provide three (3) copies of O&M Manuals for all components including wiring drawings.

The Preservation and Restoration of Farlow Park



Newton's Oldest Park

- In 1880 philanthropist John Farlow donated a parcel of land to the City of Newton to establish an open space for recreation and relaxation.
- In 1883 George Frederick Meacham, the designer of Boston Public Gardens laid out a plan for Farlow Park.
- In 1885 City Engineer Albert F. Noyes took Meacham's plan and a plan by George Schinn which featured a baseball field, and drew up a plot plan.

Meacham's Boston Public Garden

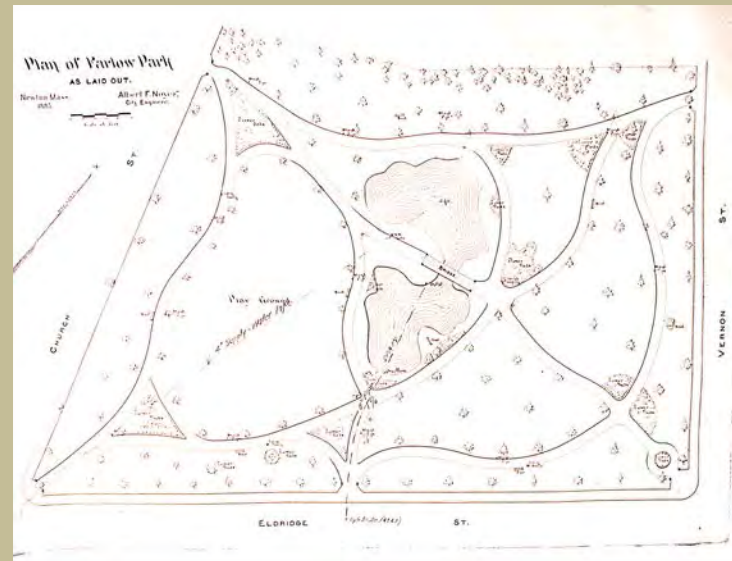
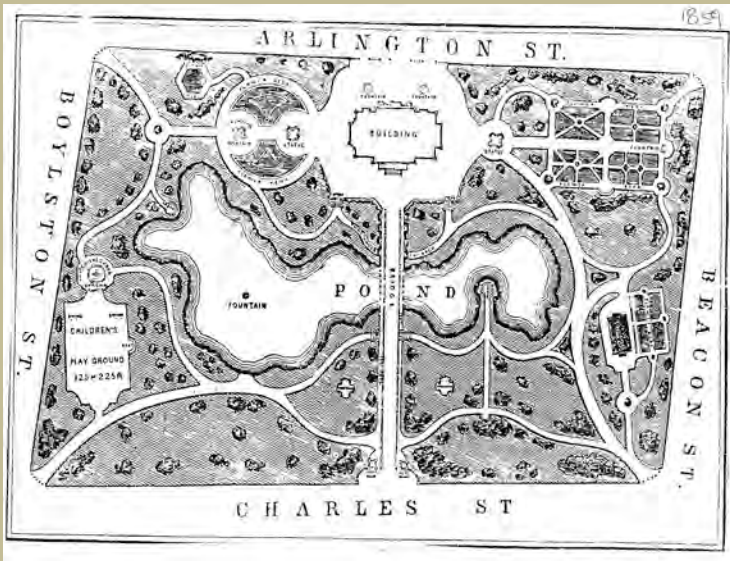

- Note the similarities of Boston Public Garden on the left and Farlow Park on the right.

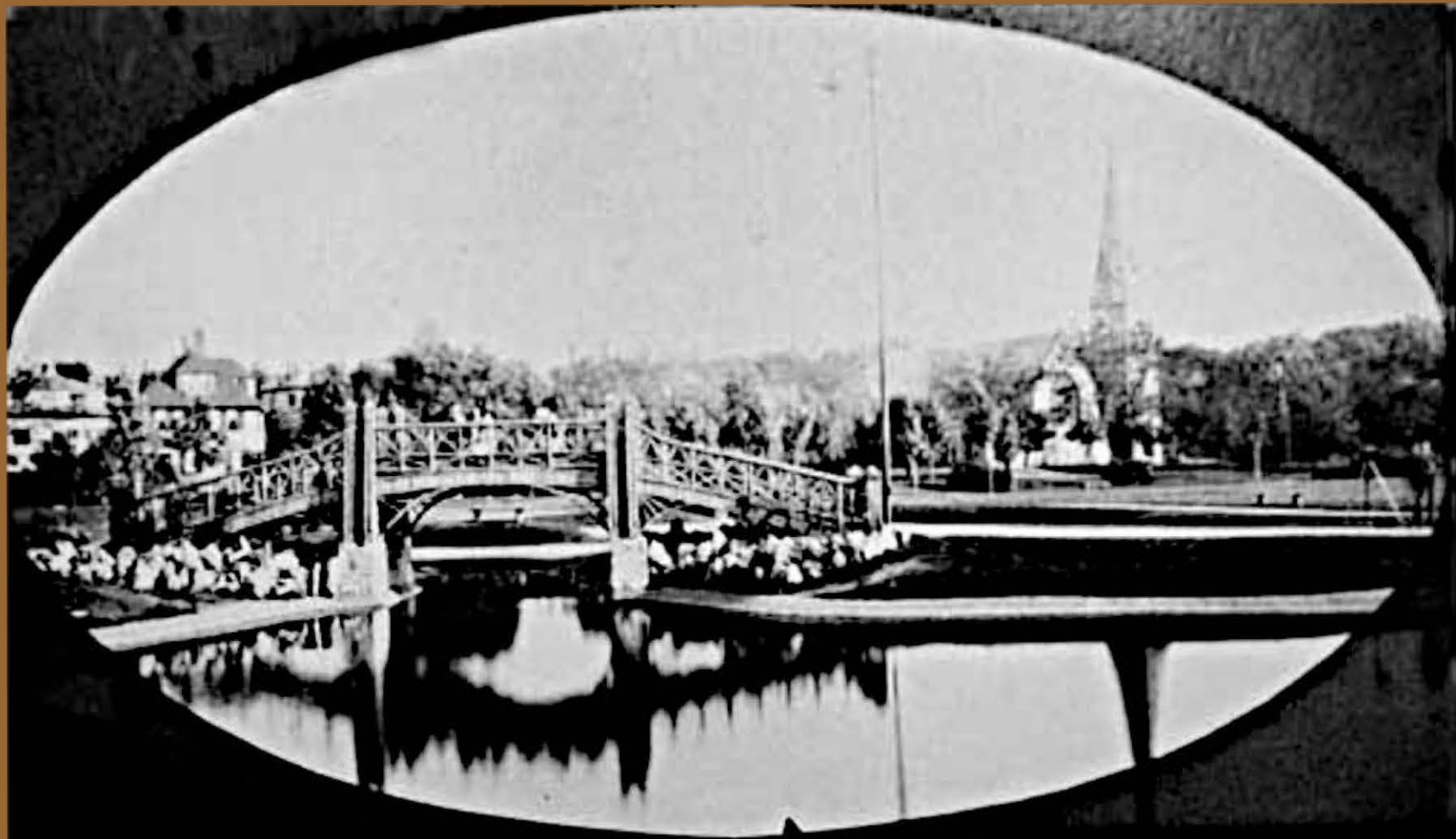

Farlow Park, Newton Corner, is seen here in 1888, shortly after the landscaping had been completed.



80005



Farlow Park, Newton, Mass.

9481



FARLOW PARK--RUSTIC BRIDGE NEWTON MASS





Farlow Park, Newton, Mass.





FARLOW – CHAFFIN PARK

HISTORIC PLANNING AND DESIGN

Landscape Restoration Report, June 2006



Prepared by
Brown, Richardson & Rowe, Inc.
Landscape Architects and Planners
with
Ammann & Whitney, Structural Engineers
CMS Collaborative, Fountain Consultants

Project funded by the Community Preservation Act



Weston and Sampson Report 2011





Pond Shell Profile

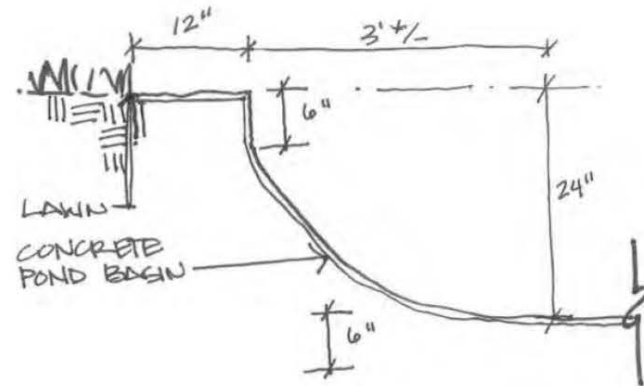

Newton Cemeteries



Newton City Hall

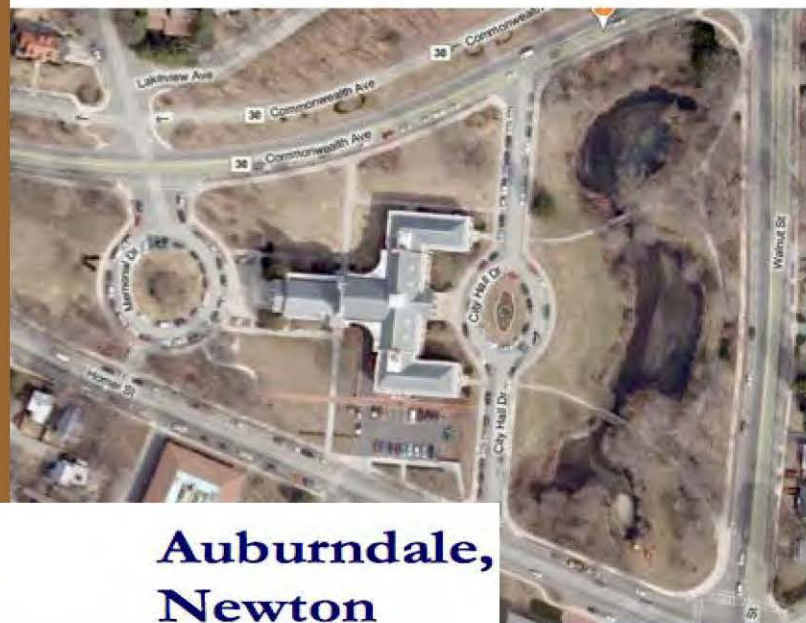

Auburndale, Newton





**Lars Anderson Park,
Brookline**



**Elm Park,
Worcester**

**Public Garden Lagoon,
Boston**



**Perkins School for the Blind,
Watertown**



Findings of Weston and Sampson Engineers, Inc.

- “Based upon the data gathered in the course of the year and extensive precedent studies conducted at similar features in public parks, near schools and playgrounds intended for young children, we have determined that the restoration of the Farlow Pond does not pose undue safety concerns.”
- We have established that well water “can be supplied to both the pond and irrigation systems for the adjacent ball field.”

Preliminary Design for Farlow Park Bridge

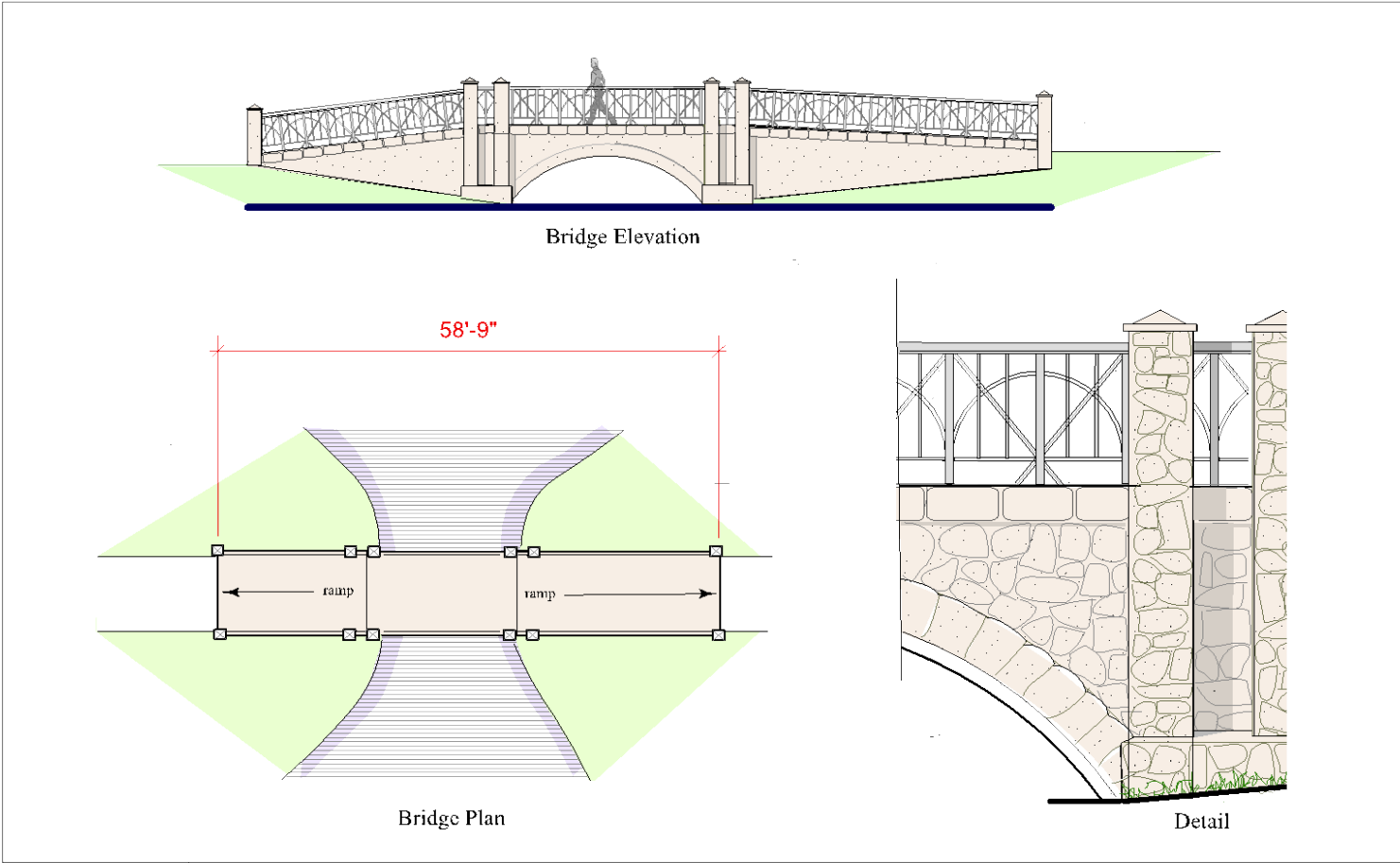

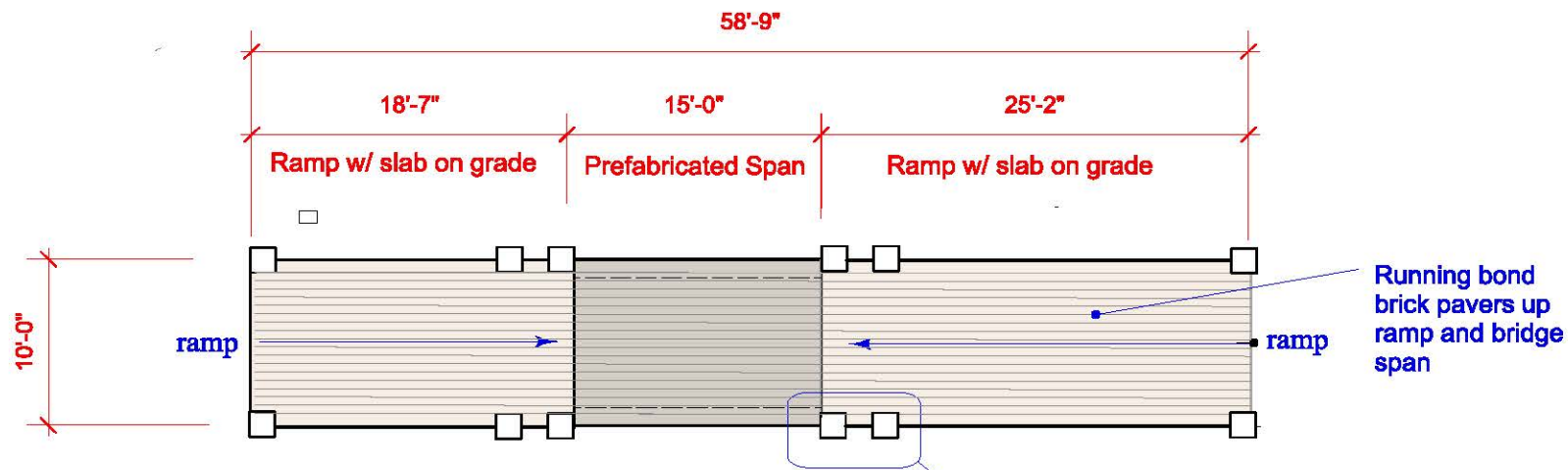

Bridge Plan

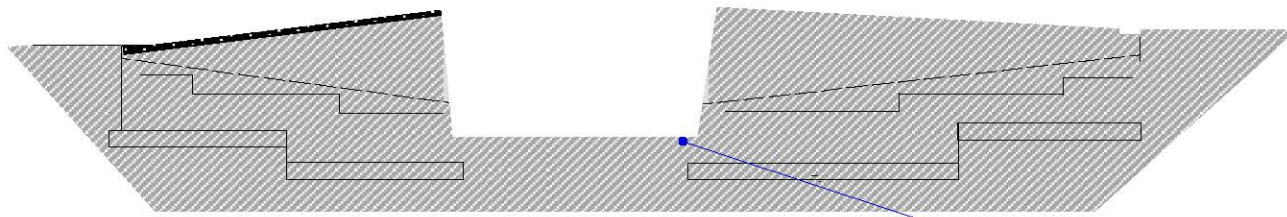

ation wall.

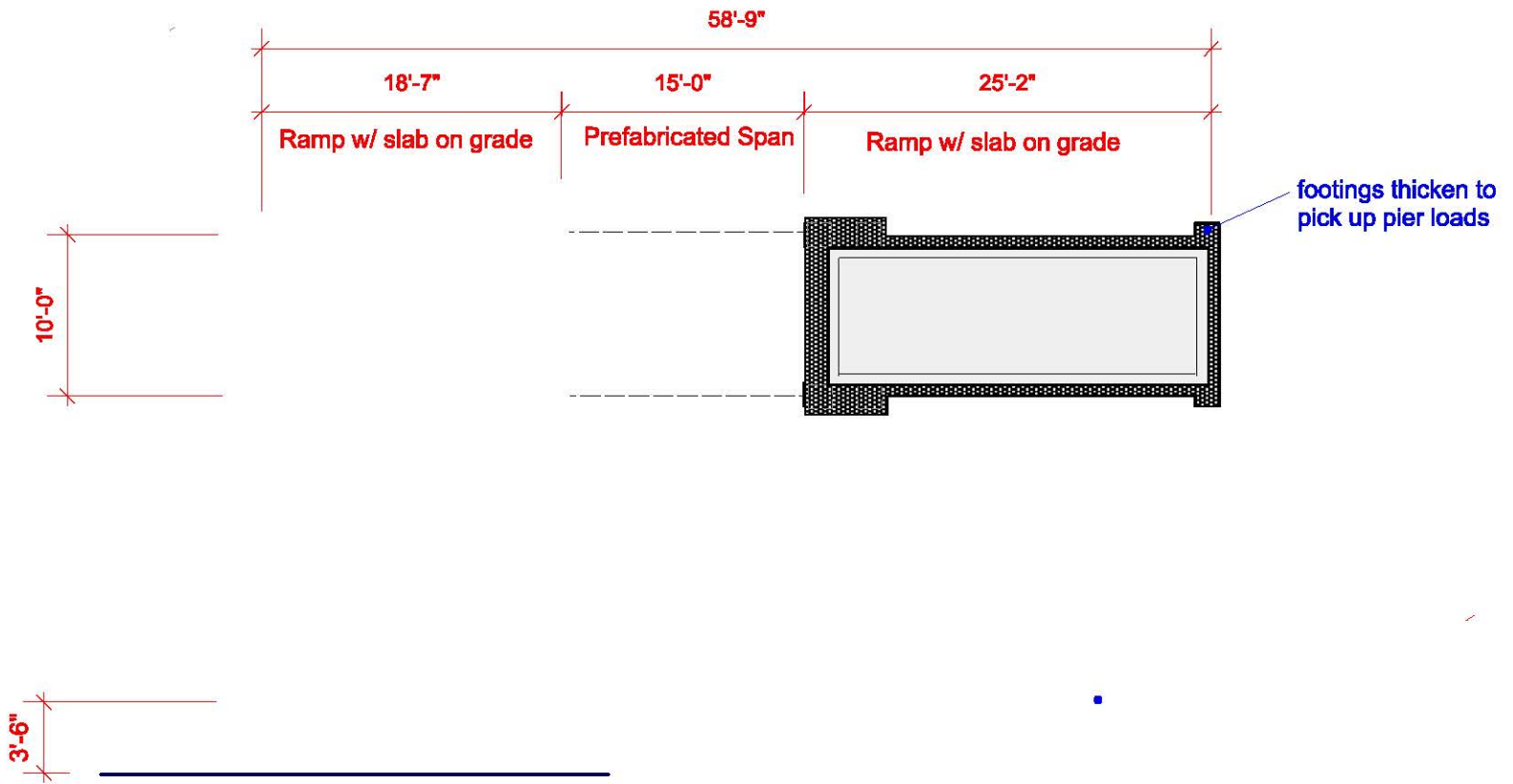

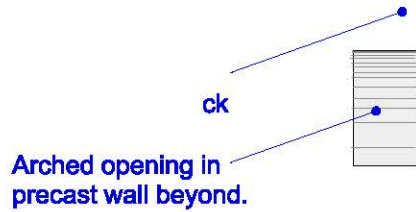

Section at Precast Span

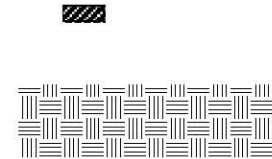

Section at ramp wall

Example of Stone Cladding for Farlow Bridge



New Irrigation system for Underwood School Playground



The Friends of Farlow Park Steering Committee

KEITH JONES, Chairman. 109 Vernon Street, Newton
Resident of Newton Corner for 20 years
Adjunct Instructor, University of Massachusetts
Member of the Newton Corner Advisory Board
Co-Chair of the Beautification Committee for Farlow Park at Underwood School (1996-2004)
Former Treasurer of the Newton Corner Neighborhood Association
Current Member of Underwood School Council

JAY WALTER, 83 Pembroke Street, Newton
Owner- Entasis Architects; PC 1994-2014
Member- American Institute of Architects.
Member- Boston Society of Architects.
Vice President Newton Historic Society/ Jackson Homestead,
Chairmen- Historic Newton Annual House Tour
Co-Chair- Historic Newton Preservation Awards
Member- Upper Falls Historic District Commission
Friends of Farlow Park- Historic park restoration project committee
Member- High Performance Buildings Coalition
Director – Newton Eco-project
Advisory Board- Green Decade Newton.

JEROME GRAFE
10 year Newton Corner resident
Father of 2 though Underwood and Bigelow, now at North
Volunteer - construction of Jack's Playground, Underwood School garden
Horticultural work experience - Mt Auburn Garden Cemetery
Member – Newton Bicycle Advisory Committee
Citizen Representative – Newton Traffic Council - 6 years
Masters Degree in Urban Planning, BU
Professional regional planner with MassDEP – 31 years.

ANDY GLUCK
24-year resident of Newton Corner
Original member of Friends of Farlow Park
SPED Teacher's Aide at Underwood School since 2006
Member of Underwood School Council
Co-Director of Underwood School Garden
Former PTO President at Underwood School and head of Playground Committee
Two children through Underwood, Bigelow and Newton North High Schools

CAROL CONNOLLY, 34 Waverly Avenue
Life long resident of Newton
Administrative Assistant for Welch Food Inc. for 27 years
Member of Newton Corner Neighborhood Association
Walk for Hunger liaison at Welch's for 15 years.
Currently a volunteer for Newton at Home

RAY ETHIER, 211 Church Street
Resident of Newton for 20 years
Owner, ATA Property Services
Volunteer at Farlow Park Beautification Program
Member of the Friends of Farlow Park

ROBERT GERST
Chair and Professor, Liberal Arts Department, Massachusetts College of Art and Design.
Chair, Newton Community Education Commission
Newton Alderman-at-Large, 1994-2006 (Vice-chair of BOA Finance Committee, Vice-chair of BOA Public Facilities Committee, Vice-chair of BOA Real Property Reuse Committee)
Moderator of the Newton Corner Neighborhood Association from 1985 to 1995.

RICHARD BELKIN, 149 Park St, Newton
Developer of Residential Properties
Resident of Newton Corner for 40 years
Chairman of the Newton Corner Advisory Committee
Former Chair of the Newton Corner Neighborhood Association.

KARNIG BOYAJIAN, 34 Eldredge Street, Newton.
Married over 50 years to the late Carol (Ramsdell) having raised four children all of whom attended Newton schools at Underwood, Bigelow and Newton North, two of whom were elected as their senior class presidents.
An original member of Friends of Farlow Park.
A resident and immediate abutter to Farlow Park for over 60 years, starting in 1954 after returning from active military duty in Korea. In early residency years saw children enjoy skating on ice in Farlow Park which reignited my early interest in the Farlow Park project.
Retired in 1958 after over 33 years military service, holding last assignment as Chief of Staff, at HQS 94th ARCOM, the U.S. Army Reserve Command at Hanscom AFB, with command responsibility for over 10,000 army reserve forces in all New England states, hundreds of civilian □ augmented personnel, and an annual budget of about \$50 million dollars.
Presently a practicing attorney for 55 years with an office in Newton Corner.

JANET STERMAN, 120 Church St, Newton
Realtor with New England Preferred Properties in Newton
Graduate of Boston University
Resident of Newton Corner and immediate abutter to Farlow Park since 1989
Chair of the Newton's Ward 1 Democratic Committee since 2009
Vice-Chair of the Newton Corner Advisory Committee since 2009
Treasurer of NewTV, Newton's PEG Access Media Center
Member of the Newton-911 Memorial Foundation
Manages the newtoncorner.org website



The Commonwealth of Massachusetts
William Francis Galvin

Minimum Fee: \$35.00

Secretary of the Commonwealth, Corporations Division
One Ashburton Place, 17th floor
Boston, MA 02108-1512
Telephone: (617) 727-9640

Articles of Organization

(General Laws, Chapter 180)

Federal Employer Identification Number: 465016007 (must be 9 digits)

ARTICLE I

The exact name of the corporation is:

FRIENDS OF FARLOW PARK, INC.

ARTICLE II

The purpose of the corporation is to engage in the following business activities:

TO RAISE MONIES AND RECEIVE DONATIONS AND GIFTS OF ANY KIND TO THE SUPPORT T
HE RESTORATION AND IMPROVEMENT OF THE BRIDGE AND POND LOCATED IN HISTORIC
FARLOW PARK IN THE NEWTON CORNER SECTION OF THE CITY OF NEWTON, MASSACHU
SETTS. TO CONDUCT ANY OTHER ACTIVITY OR EXERCISE SUCH OTHER EFFORT THAT MAY
BE NECESSARY OR INCIDENTAL THERETO THAT WILL HELP TO PRESERVE AND PROTECT T
HE SAME IN ORDER TO ALLOW ITS CONTINUED USE AND USED BY THE PUBLIC IN THE FUT
URE. TO OTHERWISE CARRY ON ANY OTHER RELATED ACTIVITY THAT WILL SUPPORT AND
BENEFIT THE ABOVE PURPOSES BY OUR ORGANIZATION AND CONSISTENT WITH ITS OBLI
GATIONS DESCRIBED IN SECTION 501(C)(3) OF THE INTERNAL REVENUE CODE BY A CORP
ORATION ORGANIZED UNDER CHAPTER 180 OF THE MASSACHUSETTS GENERAL LAWS.

ARTICLE III

A corporation may have one or more classes of members. If it does, the designation of such classes, the manner of election or appointments, the duration of membership and the qualifications and rights, including voting rights, of the members of each class, may be set forth in the by-laws of the corporation or may be set forth below:

NONE.

ARTICLE IV

Other lawful provisions, if any, for the conduct and regulation of the business and affairs of the corporation, for its voluntary dissolution, or for limiting, defining, or regulating the powers of the corporation, or of its directors or members, or of any class of members, are as follows:

(If there are no provisions state "NONE")

NO SUBSTANTIAL PART OF THE ACTIVITIES OF THIS CORPORATION SHALL BE THE CARRYI
NG ON OF THE PROPAGANDA, OR OTHERWISE ATTEMPTING TO INFLUENCE LEGISLATION
(EXCEPT AS OTHERWISE PROVIDED BY SECTION 501 (H) OF THE INTERNAL REVENUE COD
E), AND THIS CORPORATION SHALL NOT PARTICIPATE IN, OR INTERVENE IN (INCLUDING T
HE PUBLISHING OR DISTRIBUTION OF STATEMENTS), ANY POLITICAL CAMPAIGN ON BEHA
LF OF, OR IN OPPOSITION TO, ANY CANDIDATE FOR PUBLIC OFFICE. NOTWITHSTANDING,

ANY OF THE PROVISIONS OF THESE BYLAWS, THIS CORPORATION SHALL NOT CARRY ON ANY ACTIVITIES NOT PERMITTED TO BE CARRIED ON (A) BY A CORPORATION EXEMPT FROM FEDERAL INCOME TAX UNDER SECTION 501(C)(3) OF THE INTERNAL REVENUE CODE, OR (B) BY A CORPORATION, CONTRIBUTIONS TO WHICH ARE DEDUCTIBLE UNDER SECTION 170 (C)(2) OF THE INTERNAL REVENUE CODE. NO PART OF THE NET EARNINGS OF THIS CORPORATION SHALL INURE TO THE BENEFIT OF, OR BE DISTRIBUTABLE TO, ITS' MEMBERS, ITS' DIRECTORS OR TRUSTEES, OFFICERS, OR OTHER PRIVATE PERSONS, EXCEPT THAT THE CORPORATION SHALL BE AUTHORIZED AND EMPOWERED TO PAY REASONABLE COMPENSATION FOR SERVICES RENDERED AND TO MAKE PAYMENTS AND DISTRIBUTION IN FURTHERANCE OF THE PURPOSES OF THE CORPORATION.

Notes: The preceding four (4) articles are considered to be permanent and may only be changed by filing appropriate Articles of Amendment.

ARTICLE V

The by-laws of the corporation have been duly adopted and the initial directors, president, treasurer and clerk or other presiding, financial or recording officers, whose names are set out on the following page, have been duly elected.

ARTICLE VI

The effective date of organization of the corporation shall be the date approved and filed by the Secretary of the Commonwealth. If a *later* effective date is desired, specify such date which shall not be more than *thirty days* after the date of filing.

04/07/2014

ARTICLE VII

The information contained in Article VII is not a permanent part of the Articles of Organization.

a. The street address (post office boxes are not acceptable) of the principal office of the corporation in Massachusetts is:

No. and Street: 109 VERNON ST
 City or Town: NEWTON State: MA Zip: 02458 Country: USA

b. The name, residential street address and post office address of each director and officer of the corporation is as follows:

Title	Individual Name First, Middle, Last, Suffix	Address (no PO Box) Address, City or Town, State, Zip Code	Expiration of Term
PRESIDENT	KEITH M JONES	109 VERNON ST NEWTON, MA 02458 USA 109 VERNON ST NEWTON, MA 02458 USA	02/02/2016
TREASURER	JANET J STERMAN	120 CHURCH ST NEWTON, MA 02458 USA 120 CHURCH ST NEWTON, MA 02458 USA	02/02/2014
SECRETARY	JAY C WALTER	83 PEMBROKE ST NEWTON, MA 02458 USA 83 PEMBROKE ST NEWTON, MA 02458 USA	02/02/2016
VICE PRESIDENT	JAY C WALTER	83 PEMBROKE ST NEWTON, MA 02458 USA 83 PEMBROKE ST NEWTON, MA 02458 USA	02/02/2016
DIRECTOR	KARNIG BOYAJIAN	34 ELDREDGE ST NEWTON, MA 02458 USA 34 ELDREDGE ST	02/02/2016

		NEWTON, MA 02458 USA	
DIRECTOR	MAUREEN O'HARE MERCER	173 OAKLEIGH RD NEWTON, MA 02458 USA 173 OAKLEIGH RD NEWTON, MA 02458 USA	02/02/2016
DIRECTOR	CAROL A CONNOLLY	34 WAVERLY AVE NEWTON, MA 02458 USA 34 WAVERLY AVE NEWTON, MA 02458 USA	02/02/2016

c. The fiscal year (i.e., tax year) of the business entity shall end on the last day of the month of:
December

d. The name and business address of the resident agent, if any, of the business entity is:

Name: KEITH M. JONES
No. and Street: 109 VERNON ST
City or Town: NEWTON State: MA Zip: 02458 Country: USA

I/We, the below signed incorporator(s), do hereby certify under the pains and penalties of perjury that I/we have not been convicted of any crimes relating to alcohol or gaming within the past ten years. I/We do hereby further certify that to the best of my/our knowledge the above-named officers have not been similarly convicted. If so convicted, explain:

IN WITNESS WHEREOF AND UNDER THE PAINS AND PENALTIES OF PERJURY, I/we, whose signature(s) appear below as incorporator(s) and whose name(s) and business or residential address (es) beneath each signature do hereby associate with the intention of forming this business entity under the provisions of General Law, Chapter 180 and do hereby sign these Articles of Organization as incorporator(s) this 7 Day of April, 2014. (If an existing corporation is acting as incorporator, type in the exact name of the business entity, the state or other jurisdiction where it was incorporated, the name of the person signing on behalf of said business entity and the title he/she holds or other authority by which such action is taken.)

JANET J. STERMAN

THE COMMONWEALTH OF MASSACHUSETTS

I hereby certify that, upon examination of this document, duly submitted to me, it appears that the provisions of the General Laws relative to corporations have been complied with, and I hereby approve said articles; and the filing fee having been paid, said articles are deemed to have been filed with me on:

April 07, 2014 09:52 PM

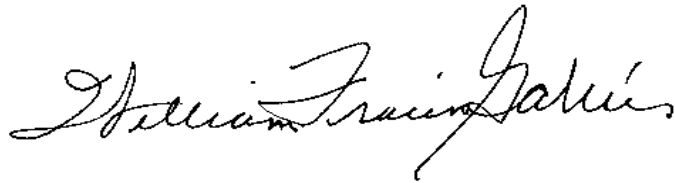
A handwritten signature in black ink, reading "William Francis Galvin". The signature is written in a cursive style with a large, prominent initial "W".

WILLIAM FRANCIS GALVIN

Secretary of the Commonwealth

Friends of Farlow Park

Additional Financial Information

During the CPC meeting on March 20, 2014 some questions were raised regarding whether the Friends of Farlow were anticipating taking care of Farlow Park once the restoration was completed. At that time we asserted that this is a City owned Park and that maintenance and utility expenses would be more than covered by the approximately \$5000 in savings in irrigation costs when a switch is made from water supplied by the MDC to well water. This was not only our opinion but was backed up by discussions we had had with Commissioner Bob DeRubeis at Parks and Recreation.

However, the Friends of Farlow Park has considered the concerns expressed by the CPC members as to what anticipated costs might take place and whether the Friends of Farlow will be available to help out. Taking into consideration the concerns expressed, the Friends of Farlow Park has committed to seeking donations of up to \$30,000 beyond the \$89,000 we have agreed to raise within our proposal.

These monies will be held in our account to be used for the following:

1. Cost overruns.
2. Future projects such as plantings and other ancillary needs such as new benches.
3. Emergency Maintenance, if Friends of Farlow Park determines the City of Newton has failed to fulfill its maintenance commitment.



Setti D. Warren
Mayor

City of Newton, Massachusetts
Department of Planning and Development
1000 Commonwealth Avenue Newton, Massachusetts 02459

Telephone
(617) 796-1120
Telefax
(617) 796-1142
TDD/TTY
(617) 796-1089
www.newtonma.gov

James Freas
Acting Director

Community Preservation Committee

MEMORANDUM

date: 18 August 2014
from: Alice Ingerson, Community Preservation Program Manager
to: The Honorable Board of Aldermen
about: **community feedback available online or in electronic form (PDF) on
2013-14 Farlow Park Pond & Bridge proposal**

The following information is being made available electronically rather than in your printed packets for this CPC funding recommendation.

from Newton's Community Preservation Committee webpage for this proposal, at
www.newtonma.gov/gov/planning/cpa/projects/farlow.asp#2013-proposal:

- ◆ CPC votes & excerpted minutes of CPC public hearings and working sessions on all Farlow Park proposals, from March 2005 (on fall 2004 proposal) through August 2014 (on fall 2013 proposal)
- ◆ 17 letters of support and approximately 20 pages of signatures on a petition of support, submitted by the Friends of Farlow Park as part of the fall 2013 proposal to the CPC

as a PDF file available on request from Karyn Dean, written community feedback received directly by the Community Preservation Committee on the fall 2013 proposal:

- ◆ comments from the League of Women Voters
- ◆ 8 letters of opposition, plus an 2nd letter from one correspondent

website www.newtonma.gov/cpa
contact Alice E. Ingerson, Community Preservation Program Manager
email aingerson@newtonma.gov *phone* 617.796.1144

CITY OF NEWTON

IN BOARD OF ALDERMEN

ORDINANCE NO. ____

September ____, 2014

BE IT ORDAINED BY THE BOARD OF ALDERMEN
OF THE CITY OF NEWTON AS FOLLOWS:

That the Revised Ordinances of Newton Massachusetts, 2012, as amended, be and hereby are further amended as follows:

Add a new **ARTICLE IX.** to Chapter 12 as follows:

Section 12-71 Plastic Bag Reduction Ordinance.

(a) **Short Title.** This Section may be cited as the "Plastic Bag Reduction Ordinance" of the City of Newton.

(b) **Declaration of findings and policy—Scope.**

(1) The Board of Aldermen hereby finds that the reduction in the use of plastic bags by commercial entities in the City of Newton (the "City") is a public purpose that protects the marine environment, advances solid waste reduction and protects waterways. This Ordinance seeks to reduce the number of plastic bags that are being used, discarded and littered, and to promote the use of reusable checkout bags by retail stores located in the City. Further, this Ordinance seeks to reduce the use of paper bags, due to their greater use of natural resources and higher cost impacts on retailers.

(c) **Definitions.**

(1) The following words shall, unless the context clearly requires otherwise, have the following meanings:

(a) "Department" means the City's Department of Health and Human Services.

(b) "Commissioner" means the City's Commissioner of Health and Human Services.

(c) "Checkout Bag" means a carryout bag provided or sold by a Retail Establishment to a customer at the point of sale. A Checkout Bag shall not include:

(i) bags, whether plastic or not, in which loose produce or products are placed by a consumer to deliver such items to the point of sale or check-out area of a Retail Establishment;

(ii) laundry or dry-cleaner bags; or

(iii) newspaper bags.

(d) "Recyclable Paper Bag" means a paper bag that is 100 percent recyclable and contains at least 40% post-consumer recycled content, and displays the words "Recyclable" and "made from 40% post-consumer recycled content" in a visible manner on the outside of the bag.

(e) "Reusable Bag" means a bag with handles that is specifically designed and manufactured for multiple reuse and is either polyester, polypropylene, cotton or other durable material, or durable plastic that is at least 3.0 millimeters in thickness.

(f) "Retail Establishment" means any commercial entity with retail space of 3500 square feet or larger or with at least two (2) locations under the same name within the City of Newton with retail space that totals 3500 square feet or larger, whether for or not for profit, including, but not limited to retail stores, restaurants, pharmacies, convenience and grocery stores, liquor stores, seasonal and temporary businesses.

(d) **Requirements.**

(1) If a Retail Establishment provides or sells Checkout Bags to customers, such bags shall be either a Recyclable Paper Bag or a Reusable Bag.

(2) The Commissioner shall have the authority to promulgate regulations to accomplish any of the provisions of this Section.

(3) Each Retail Establishment as defined herein shall comply with this Section.

(e) **Effective Date.**

This Section shall take effect one hundred and eighty (180) days from the date of enactment.

(f) **Exemption.**

(1) The Commissioner may exempt a Retail Establishment from the requirements of this Section for a period of up to six (6) months, upon a finding by the Commissioner that the requirements of this Section would cause undue hardship to a Retail Establishment. An "undue hardship" shall only be found in circumstances where a Retail Establishment requires additional time in order to draw down an existing inventory of single-use plastic check out bags or paper bags which do not meet the definition of recyclable paper bag. Any Retail Establishment receiving an exemption shall file with the Commissioner monthly reports on inventory reduction and remaining stocks.

(2) Any Retail Establishment shall apply for an exemption to the Commissioner using forms provided by the Department, and shall allow the Commissioner or his or her designee, access to all information supporting its application.

(3) The Commissioner may approve the exemption request, in whole or in part, with or without conditions

(4) The Commissioner, by regulation, may establish a fee for exemption requests.

(g) **Enforcement.**

(1) **Fine.** Any Retail Establishment which violates any provision of this Section or any regulation established by the Commissioner shall be liable for a fine as follows: First offense, warning; second offense, \$100.00; third offense, \$200.00; fourth and subsequent offenses, \$300.00. Each day a violation occurs shall constitute a separate offense.

(2) Whoever violates any provision of this Section or any regulation established by the Commissioner may be penalized by a noncriminal disposition as provided in G.L. c. 40, §21D. For purposes of this section, the Commissioner of the Health and Human Services, or his or her designee, shall be enforcing persons.

(h) **Severability.**

Each separate provision of this Section shall be deemed independent of all other provisions herein, and if any provision of this Section be declared to be invalid by a court of competent jurisdiction, the remaining provisions of this Section shall remain valid and enforceable.

In Sec. 20-21. Enforcing persons and revised ordinances subject to civil fine.

Amend paragraph (b), HEALTH AND HUMAN SERVICES DEPARTMENT, by adding after CITY ORDINANCES, Any offense, the following:

.....PENALTY

Section 12-71. Plastic Bag Reduction Ordinance

- () First offense..... Warning
- () Second offense.....\$100.00
- () Third offense.....\$200.00
- () Fourth or subsequent offenses.....\$300.00

Approved as to legal form and character:

(SGD) _____
City Solicitor

Under suspension of Rules
Readings Waived and Adopted
___ yeas and ___ nays

(SGD) _____
City Clerk

(SGD) _____
Mayor

CITY OF NEWTON

IN BOARD OF ALDERMEN

ORDINANCE NO. ____

~~September March~~ ____, 2014

BE IT ORDAINED BY THE BOARD OF ALDERMEN
OF THE CITY OF NEWTON AS FOLLOWS:

- That the Revised Ordinances of Newton Massachusetts, 2012, as amended, be and hereby are further amended as follows:

Add a new **ARTICLE IX.** to Chapter 12 as follows:

Section 12-71 Plastic Bag Reduction Ordinance.

(a) **Short Title.** This Section may be cited as the "Plastic Bag Reduction Ordinance" of the City of Newton.

(b) **Declaration of findings and policy—Scope.**

(1) The Board of Aldermen hereby finds that the reduction in the use of plastic bags by commercial entities in the City of Newton (the "City") is a public purpose that protects the marine environment, advances solid waste reduction and protects waterways. This Ordinance seeks to reduce the number of plastic bags that are being used, discarded and littered, and to promote the use of reusable checkout bags by retail stores located in the City. Further, this Ordinance seeks to reduce the use of paper bags, due to their greater use of natural resources and higher cost impacts on retailers. ~~This Ordinance also seeks to ensure that customers using reusable checkout bags are made aware of the need to keep those bags sanitized between uses in order to protect against the transmission of food-borne illnesses.~~

(c) **Definitions.**

(1) The following words shall, unless the context clearly requires otherwise, have the following meanings:

(a) "Department" means the City's Department of Health and Human Services.

(b) "Commissioner" means the City's Commissioner of Health and Human Services.

(c) "Checkout Bag" means a carryout bag provided or sold by a Retail Establishment to a customer at the point of sale. A Checkout Bag shall not include:

- (i) bags, whether plastic or not, in which loose produce or products are placed by a consumer to deliver such items to the point of sale or check-out area of a Retail Establishment;
- (ii) laundry or dry-cleaner bags; or
- (iii) newspaper bags.

(d) "Recyclable Paper Bag" means a paper bag that is 100 percent recyclable and contains at least 40% post-consumer recycled content, and displays the words "Recyclable" and "made from 40% post-consumer recycled content" in a visible manner on the outside of the bag.

(e) "Reusable Bag" means a bag with handles that is specifically designed and manufactured for multiple reuse and is either polyester, polypropylene, cotton or other durable material, or durable plastic that is at least 3.0 millimeters in thickness.

(f) "Retail Establishment" means ~~(1) any commercial~~ entity/enterprise with retail space of 3500 square feet or larger; or with at least two (2) locations under the same name within the City of Newton with retail space that totals 3500 square feet or larger, whether for or not for profit, including, but not limited to retail stores, restaurants, pharmacies, convenience and grocery stores, liquor stores, seasonal and temporary businesses, ~~; or (2) any commercial enterprise, whether for or not for profit, operating or participating in farmers' markets, festivals, bazaars or street fairs.~~

(d) **Requirements.**

(1) If a Retail Establishment provides or sells Checkout Bags to customers, such bags shall be either a Recyclable Paper Bag or a Reusable Bag. ~~Public information advising customers to sanitize Reusable Bags to prevent food borne illness must be prominently displayed or communicated at the point of provision or sale.~~

(2) The Commissioner shall have the authority to promulgate regulations to accomplish any of the provisions of this Section.

(3) Each Retail Establishment as defined herein shall comply with this Section.

(e) **Effective Date.**

This Section shall take effect one hundred and eighty (180) days from the date of enactment.

(f) **Exemption.**

(1) The Commissioner may exempt a Retail Establishment from the requirements of this Section for a period of up to six (6) months, upon a finding by the Commissioner that the requirements of this Section would cause undue hardship to a Retail Establishment. An "undue hardship" shall only be found in circumstances where a Retail Establishment requires additional time in order to draw down an existing inventory of single-use plastic check out bags or paper bags which do not meet the definition of recyclable paper bag. Any Retail Establishment receiving an exemption shall file with the Commissioner monthly reports on inventory reduction and remaining stocks.

(2) Any Retail Establishment shall apply for an exemption to the Commissioner using forms provided by the Department, and shall allow the Commissioner or his or her designee, access to all information supporting its application.

(3) The Commissioner may approve the exemption request, in whole or in part, with or without conditions

(4) The Commissioner, by regulation, may establish a fee for exemption requests.

(g) **Enforcement.**

(1) **Fine.** Any Retail Establishment which ~~shall~~ violates any provision of this Section or any regulation established by the Commissioner shall be liable for a fine as follows: First offense, warning; second offense, \$100.00; third offense, \$200.00; fourth and subsequent offenses, \$300.00. ~~of \$300 and e~~ Each day a violation occurs shall constitute a separate offense.

(2) Whoever violates any provision of this Section or any regulation established by the Commissioner may be penalized by a noncriminal disposition as provided in G.L. c. 40, §21D. For purposes of this section, the Commissioner of the Health and Human Services, or his or her designee, shall be enforcing persons.

(h) **Severability.**

Each separate provision of this Section shall be deemed independent of all other provisions herein, and if any provision of this Section be declared to be invalid by a court of competent jurisdiction, the remaining provisions of this Section shall remain valid and enforceable.

-And-

In Sec. 20-21. Enforcing persons and revised ordinances subject to civil fine.

Amend paragraph (b), HEALTH AND HUMAN SERVICES DEPARTMENT, by adding after CITY ORDINANCES, Any offense, the following:

.....PENALTY

Section 12-71. Plastic Bag Reduction Ordinance

() ~~Any offense~~First -

.....offense.....

.....\$300.00Warning

() Second offense.....\$100.00

() Third offense.....\$200.00

() Fourth or subsequent offenses.....\$300.00

Approved as to legal form and character:

(SGD) _____
City Solicitor

Under suspension of Rules
Readings Waived and Adopted
___ yeas and ___ nays

(SGD) _____
City Clerk

(SGD) _____
Mayor

Sec. 2-1. Composition; Eligibility; Election and Term.

(a) Composition—There shall be a Board of Aldermen of twenty-four members which shall exercise the legislative powers of the City. Sixteen of these members, to be known as aldermen or alderwomen at large, shall be nominated and elected by the voters at large, two such aldermen or alderwomen at large to be elected from each of the eight wards of the City. The other eight members, to be known as ward aldermen or alderwomen, shall be nominated and elected by and from the voters of each ward, one ward alderman or alderwoman to be elected from each of the eight wards of the City. The Board of Aldermen shall be the judge of the election and qualification of its members.

(b) Eligibility—Only voters shall be eligible to hold the office of alderman or alderwoman. A candidate for the office of alderman or alderwoman shall be a resident of the ward from which he or she seeks election as of the date that the election commission makes available blank forms for the nomination of candidates for office. In order to hold the office of alderman or alderwoman, a candidate shall have continuously been a resident of the ward from which he or she is elected from the date that the election commission made the blank forms available until and including the first day of the term for which he or she is elected. A member of the Board of Aldermen shall, notwithstanding his or her removal from one ward of the City to another, continue to serve and to perform his or her official duties during his or her term of office. The removal from residency within the City shall create a vacancy in such office.

Sec. 2-5. Filling of Vacancies.

(b) After Regular City Election—If such vacancy shall occur after fifteen calendar months of the term for which aldermen are elected, no special election shall be held. In the case of a vacancy in the office of ward alderman, the person elected at the next regular City election to the seat in which the vacancy exists shall immediately be sworn and shall, in addition to the term for which he or she was elected, serve for the balance of the then unexpired term. In the case of a vacancy in the office of alderman at large, the person elected at the next regular City election to the seat in which the vacancy exists shall immediately be sworn and shall, in addition to the term for which he or she was elected, serve for the balance of the then unexpired term. If no incumbent alderman at large from the ward in which the vacancy exists is elected at such election for such office, the candidate who receives the highest number of votes shall be deemed to be elected to the seat in which the vacancy exists and shall serve as aforesaid.