

CITY OF NEWTON

IN BOARD OF ALDERMEN

PUBLIC SAFETY & TRANSPORTATION COMMITTEE REPORT

WEDNESDAY, SEPTEMBER 9, 2015

Present: Ald. Ciccone (Chair), Yates, Cote, Fuller, Lipof, Harney and Schwartz

Absent: Ald. Johnson

Also Present: Ald. Crossley (Chair), Lennon, Gentile, Lappin, Danberg, Laredo and Brousal-Glaser

Absent: Ald. Albright

City Staff: Captain David MacDonald, Newton Police Department; Chief Bruce Proia and Acting Assistant Chief Gino Lucchetti, Newton Fire Department; Joshua Morse, Commissioner, Public Buildings; Maureen Lemieux, Chief of Staff/Chief Financial Officer; Shane Mark, Director of Operations, Public Works Department and James McGonagle, Commissioner of Public Works

#414-13(3) HIS HONOR THE MAYOR, requesting authorization to petition the General Court for Home Rule Legislation to amend the provisions of the Acts 2014, c.96 *An Act Relative to the Appointment of Special Officers in Newton* by raising the age limit for service on the special retiree police detail patrol from age 65 to age 70. [08/14/15 @ 11:37 AM]

ACTION: **APPROVED 7-0**

NOTE: Captain MacDonald joined the Committee for discussion on this item.

Captain MacDonald stated that in June 2014, Newton began using six retired police officers (under the age of 65) to perform police details alleviating some department issues. There are currently two retirees now over the age of 65 who desire to continue performing details in the City. The City and the retirees are both benefiting because the retirees are experienced and properly trained at no expense to the City and allow the retiree to continue earning wages. The Police Department has not received any complaints and did not take any disciplinary actions.

Committee members expressed their questions regarding amending this legislation.

Questions:

Committee members asked if there is a mandatory health screening for the retiree? Is the City fulfilling 100% of necessary details? Is it possible for the Auxiliary Police to perform details? Are there different standards for retirees versus officers?

Captain MacDonald answered that the retiree is required to pass a health-screening test at their expense. The City is doing better than Fiscal Year 2014 with fulfilling details required because of these additional six retirees. The Police Department would have to bargain with the Police Department Unions to have the Auxiliary Police perform details. Retirees are limited to

performing details, they are not assigned other police tasks. A retiree may be terminated with a fourteen-day notice. Officers are responsible for their weapons, equipment purchases and their own transportation.

Committee members said that they support raising the age limit from age 65 to age 70. Without further discussion, Ald. Yates made the motion to approve amending this legislation. Committee members agreed 7-0.

REFERRED PUBLIC SAFETY & TRANSPORTATION AND FINANCE COMMITTEES

#218-15 HIS HONOR THE MAYOR requesting authorization to appropriate the sum of six hundred fifty thousand dollars (\$650,000) from bonded indebtedness for the purpose of purchasing a new pumper truck for the Fire Department. [08/31/15 3:08 PM]

ACTION: **APPROVED 6-0, Ald. Fuller not voting**

NOTE: Chief Proia and Acting Assistant Chief Lucchetti joined the Committee for discussion on this item.

Chief Proia stated that several years ago he wrote an apparatus replacement plan for all Fire Department vehicles. The department uses the National Fire Protection Association (NFPA). The NFPA recommends standards for replacing fire apparatus. There are currently nine first hand apparatus vehicles that are well over 15 years of age.

The FY'16 Capital Improve Plan (CIP) included replacing a 1999 pumper truck. The 1999 pumper truck exceeds the NFPA 15-year life expectancy. The pumper truck will be used as a spare in the City. The department always tries to maintain three dependable spare vehicles.

The appropriation for \$650,000 will allow the department to purchase from E-One a new Custom 42 Pumper E-One Typhoon X Medium Cab 4x2 Chassis to be used at Station #10.

Committee members expressed their questions regarding this appropriation.

Questions:

Committee members asked what type of technology changes in a vehicle over 15 years of age and is a 15-year old truck too old? Will this pumper truck be sold or surplus? How many manufactures are in the area? The quote from E-One states \$594,117, this appropriation requests \$650,000 why the difference? How many bids did the City receive on a new pumper truck? Do the trucks have standard equipment?

Vehicles change over the years including emergency egress, safety features, hydraulics, electronics, computers, sensors, alarms and phones. This pumper truck will be used as a spare truck in the fleet. There are approximately five manufacturers in the area. Chief Proia stated that once the specs for a truck are complete the cost is set by MAPC according to chosen specs. The City has satisfactorily purchased three trucks from E-One. The approximate \$55,000 difference is for the necessary new equipment and mounting fees including hoses, tools, radios, nozzles and generators. The City's mechanics are always being educated on newer equipment.

Without further discussion, Ald. Lipof made the motion to approve this appropriation. Committee members agreed 6-0, Ald. Fuller not voting.

REFERRED PUBLIC SAFETY & TRANSPORTATION AND FINANCE COMMITTEES

#217-15 HIS HONOR THE MAYOR requesting authorization to appropriate the sum of five hundred four thousand seven hundred fifty dollars (\$504,750) from bonded indebtedness for the purpose of purchasing new Self Contained Breathing Apparatus (SCBA) with GPS tracking devices for the Fire Department. [08/31/15 3:08 PM]

ACTION: APPROVED 5-0, Ald. Fuller and Schwartz not voting

NOTE: Chief Proia and Acting Assistant Chief Lucchetti joined the Committee for discussion on this item.

Chief Proia stated the FY'16 Capital Improve Plan (CIP) included replacing the self-contained breathing apparatus gear (SCBA) purchased in 2007. This equipment includes each firefighter receiving their own new face piece with GPS technology to allow the safety officer on the scene to track firefighter's location and the elevation inside a building. Chief Proia stated that this is a firefighter's most important tool and the biggest advancement in firefighter safety.

The department is spending approximately \$2,000 to \$3,000 to repair each piece of equipment. The appropriation for \$504,750 will allow the department to purchase from Industrial Protection Services, LLC. Sixty harnesses, 20 thirty-minute cylinders, 2 sixty-minute cylinders, 187 face pieces, 2 pak trackers and 2 truck chargers.

Committee members asked if the quote dated January 24, 2015 is still appropriate?

Chief Proia answered that he hold off on purchasing the equipment until the CIP was approved.

Without further discussion, Ald. Cote made the motion to approve this appropriation. Committee members agreed 5-0, Ald. Fuller and Schwartz not voting.

REFERRED PUBLIC SAFETY & TRANSPORTATION AND FINANCE COMMITTEES

#216-15 HIS HONOR THE MAYOR requesting authorization to appropriate the sum of two hundred twenty-seven thousand seven hundred dollars (\$227,700) from bonded indebtedness for the purpose of purchasing a new bucket truck for the Fire Department. [08/31/15 3:08 PM]

ACTION: APPROVED 5-0, Ald. Fuller and Schwartz not voting

NOTE: Chief Proia and Acting Assistant Chief Lucchetti joined the Committee for discussion on this item.

Chief Proia stated that the department uses the National Fire Protection Association (NFPA). The NFPA recommends standards for replacing fire apparatus. There are currently nine first hand apparatus vehicles that are well over 15 years of age.

Chief Proia stated that the FY'16 Capital Improve Plan (CIP) included replacing a 1996 bucket that did not pass inspection due to a cracked frame and is therefore off the road. This truck serves 50% of work in the City including wires, lines and business fire alarm systems. Most recently, the City has borrowed bucket trucks from surrounding communities.

The appropriation for \$227,700 will allow the department to purchase from Taylor & Lloyd, Inc. a new 2016 4300SBA Cab & Chassis.

Without discussion, Ald. Lipof made the motion to approve this appropriation. Committee members agreed 5-0, Ald. Fuller and Schwartz not voting.

REFERRED TO PS&T AND PUBLIC FACILITIES COMMITTEES

#413-11 ALD. CICCONE, SALVUCCI, GENTILE & LENNON updating the Public Facilities and Public Safety & Transportation Committees on the progress of renovations to the city's fire stations. [11/17/11 @11:07 AM]

ACTION: **HELD 6-0, Ald. Harney not voting**
PUBLIC FACILITIES HELD 7-0

NOTE: The Public Safety & Transportation Committee discussed the item jointly with the Public Facilities Committee. Please refer to the Public Facilities report for a detailed account of this discussion including the PowerPoint presented.

Ald. Schwartz made the motion to hold this item. Committee members agreed 6-0, Ald. Harney not voting.

At approximately 9:00 pm, the Committee adjourned.

Respectfully submitted,

Allan Ciccone, Jr. Chairman



SETTI D. WARREN
MAYOR

City of Newton, Massachusetts
Office of the Mayor

#414-13(3)

Telephone
(617) 796-1100

Facsimile
(617) 796-1113

TDD/TTY
(617) 796-1089

E-mail
swarren@newtonma.gov

August 14, 2015

Honorable Board of Aldermen
Newton City Hall
1000 Commonwealth Avenue
Newton, MA 02459

Ladies and Gentlemen:

I write to request that your Honorable Board docket for consideration a request to petition the General Court for special legislation to amend the provisions of the Acts 2014, c. 96 *An Act Relative to the Appointment of Special Police Officers in Newton* by raising the age limit for service on the special retiree police detail patrol from age 65 to age 70.

In addition, and in the event such special legislation is enacted by the General Court, I request that this Honorable Board docket for consideration a corresponding amendment to Section 24-6, of the Newton Revised Ordinances, 2012, in order to implement such special legislation.

Thank you for your consideration of this matter.

Very truly yours,

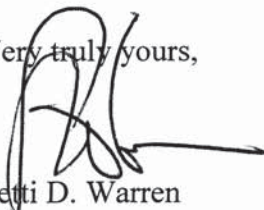
Setti D. Warren
Mayor

RECEIVED
Newton City Hall
2015 AUG 14 AM 11:37
David A. Olson, OMO
Newton, MA 02459



Acts 2014

Chapter 96 AN ACT RELATIVE TO THE APPOINTMENT OF SPECIAL POLICE OFFICERS IN THE CITY OF NEWTON

RECEIVED
Newton City Clerk
2015 AUG 14 AM 11:37
Doris A. Olson, CMC
Newton, MA 02459

Be it enacted by the Senate and House of Representatives in General Court assembled and by the authority of the same as follows:

SECTION 1. The mayor of the city of Newton may appoint, at the recommendation of the police chief and as the police chief deems necessary, retired Newton police officers as special police officers to perform police details or any duties arising therefrom or during the course of police detail work, whether or not related to the detail work. The retired Newton police officers shall have been regular Newton police officers and retired based on superannuation. ~~They shall be subject to the same~~ Notwithstanding the maximum age restrictions as applied to regular Newton police officers under chapter 32 of the General Laws, the retired Newton police officers shall be eligible to serve as special police officers pursuant to this Act until they reach the age of 70. Prior to appointment under this act, a retired Newton police officer shall pass a medical examination by a physician or other certified professional chosen by the city to determine whether the retired Newton police officer is capable of performing the essential duties of a special police officer under this act, the cost of which shall be borne by the retired Newton police officer.

SECTION 2. Special police officers appointed under this act shall not be subject to chapter 31, section 99A of chapter 41, chapter 150E or chapter 151A of the General Laws. Special police officers appointed under this act shall not be eligible for special leave, vacation or other benefits enumerated in article II of chapter 2 of Newton revised ordinances 2012.

SECTION 3. Special police officers shall, when performing the duties under section 1, have the same power to make arrests and perform other police functions as do regular police officers of the city of Newton.

SECTION 4. Special police officers shall be appointed for an indefinite term, subject to removal by the mayor or the chief of police at any time upon 14 days written notice prior to removal.

SECTION 5. The workweek for special police officers appointed under this act shall be 7 consecutive 24 hour periods, for a total of 168 hours, which shall commence at 8:00 A.M. each

Monday. A special police officer appointed under this act shall not perform police details or any duties arising therefrom in excess of 40 hours in a workweek.

SECTION 6. Special police officers appointed under this act shall be subject to the rules, regulations, policies, procedures and requirements imposed by the chief of police and the mayor of the city of Newton including, but not limited to: restrictions on the type of detail assignments, requirements regarding medical examinations to determine continuing capability to perform the duties of a special police officer, requirements for training, requirements for firearms licensing and qualifications and requirements regarding uniforms and equipment. Compliance with all requirements shall be at no cost to the city of Newton. Special police officers appointed under this act shall not be subject to section 96B of chapter 41 of the General Laws.

SECTION 7. Special police officers appointed under this act shall be sworn before the city clerk of the city of Newton who shall keep a record of all of the appointments.

SECTION 8. Special police officers appointed under this act shall be subject to sections 100 and 111F of chapter 41 of the General Laws. The amount payable under said section 111F shall be calculated by averaging the amount earned over the prior 52 weeks as a special police officer working police details, or averaged over such lesser period of time for any officer designated as a special police officer less than 52 weeks before the incapacity. In no event shall payment under said section 111F exceed, in any calendar year, the limitation on earnings contained in paragraph (b) of section 91 of chapter 32 of the General Laws. Payment under section 111F of chapter 41 of the General Laws shall terminate in accordance with said section 111F or when a special police officer appointed under this act reaches the age of 6570, whichever occurs first. ~~If the age limitation applicable to regular police officers serving a city is increased from 65 years of age, the termination of benefits under said section 111F, as provided in this section for special police officers, shall terminate at such a higher age limit, but in no event shall the benefits extend beyond the age of 70 for any such special police officer.~~ Special police officers appointed under this act shall not be subject to section 85H or 85H 1/2 of said chapter 32 or eligible for the benefits.

SECTION 9. Appointment as a special police officer shall not entitle that person to assignment to any detail.

SECTION 10. Special police officers appointed under this act shall be subject to the limitations on hours worked and earnings restrictions as provided in paragraph (b) of section 91 of chapter 32 of the General Laws.

SECTION 11. This act shall take effect upon its passage.

Sec. 24-6 Police Retiree Detail Patrol

The mayor may appoint, at the recommendation of the police chief and as the police chief deems necessary, retired Newton police officers as special police officers, to be known as the Newton Police Retiree Detail Patrol, to perform police details or any duties arising therefrom or during the course of police detail work, whether or not related to the detail work, subject to the following requirements and conditions. Special police officers appointed under this section shall be paid for performing assigned details at the same rate as regular police officers performing assigned details.

(a) The retired police officers shall have been regular Newton police officers and retired from Newton based on superannuation. ~~They shall be subject to the same~~ Notwithstanding the maximum age restrictions ~~as~~ applied to regular Newton police officers under chapter 32 of the General Laws, retired police officers shall be eligible to serve as special police officers under this section until they reach the age of 70.

(b) Prior to appointment under this section, a retired Newton police officer shall pass a medical examination by a physician or other certified professional chosen by the City to determine whether the retired Newton police officer is capable of performing the essential duties of a special police officer under this section, the cost of which shall be borne by the retired Newton police officer.

(c) Special police officers appointed under this section shall not be subject to chapter 31 of the General Laws, section 99A of chapter 41 of the General Laws, chapter 150E of the General Laws, or chapter 151A of the General Laws. Special police officers appointed under this section shall not be eligible for special leave, vacation, or other benefits enumerated in article II of chapter 2 of these ordinances.

(d) Special police officers shall, when performing the duties under this section, have the same power to make arrests and perform other police functions as do regular police officers of the City of Newton.

(e) Special police officers shall be appointed for an indefinite term, subject to removal by the mayor or the chief of police at any time with a 14 day written notice.

(f) The workweek for special police officers appointed under this section shall be seven (7) consecutive twenty-four (24) hour periods, for a total of one hundred and sixty-eight (168) hours, which shall commence at 8:00 A.M. at the start of each Monday of the calendar week. In no case shall any special police officer appointed under this section perform police details or any duties arising therefrom in excess of forty (40) hours in any given workweek.

(g) Special police officers appointed under this section shall be subject to the rules and regulations, policies and procedures and requirements as the chief of police and the mayor may impose from time to time, including, but not limited to restrictions on the type of detail assignments, requirements regarding medical examinations to determine continuing capability to perform the duties of a special police officer, requirements for training, requirements for firearms licensing and qualifications and requirements regarding uniforms and equipment. Compliance with all requirements will be at no cost to the City of Newton. Special police officers appointed under this section shall not be subject to section 96B of chapter 41 of the General Laws.

(h) Special police officers appointed under this section shall be sworn before the city clerk of the City of Newton who shall keep a record of all such appointments.

(i) Special police officers appointed under this section shall be subject to sections 100 and 111F of chapter 41 of the General Laws. The amount payable under section 111F of chapter 41 shall be

calculated by averaging the amount earned over the prior 52 weeks as a special police officer working police details, or averaged over such lesser period of time for any officer designated as a special police officer less than 52 weeks before the incapacity. In no event shall payment under section 111F of chapter 41 exceed, in any calendar year, the limitation on earning contained in paragraph (b) of section 91 of chapter 32 of the General Laws. Payment under section 111F of chapter 41 shall terminate in accordance with section 111F of Chapter 41 or when a special police officer appointed under this section reaches the age of ~~65~~70, whichever occurs sooner. ~~If the age limitation applicable to regular police officers serving a city is increased from 65 years of age, the termination of benefits under section 111F of chapter 41, as provided in this section for special police officers, shall terminate at such a higher age limit, but in no event shall the benefits extend beyond the age of 70 for any such special police officer.~~ Special police officers appointed under this section shall not be subject to section 85H or 85H 1/2 of chapter 32, nor eligible for any benefits pursuant thereto.

(j) Appointment as a special police officer under this section does not entitle that person to assignment to any detail.

(k) Retired Newton police officers serving as special police officers under this section shall be subject to the limitations on hours worked and on earnings restrictions as provided in paragraph (b) of section 91 of chapter 32 of the General Laws. (Ord. No. A-45, 09-15-14)

CITY OF NEWTONIN BOARD OF ALDERMEN

December 16, 2013

ORDERED:

That the Board of Aldermen hereby requests and authorizes His Honor the Mayor to submit a home rule petition to the General Court seeking the adoption of special legislation as set forth below:

Be it enacted by the Senate and House of Representatives in General Court assembled, and by the authority of the same, as follows:

SECTION 1. The mayor of the City of Newton may appoint, at the recommendation of the police chief and as the police chief deems necessary, retired Newton police officers as special police officers to perform police details or any duties arising therefrom or during the course of police detail work, whether or not related to the detail work. The retired Newton police officers shall have been regular Newton police officers and retired based on superannuation. They shall be subject to the same maximum age restrictions as applied to regular Newton police officers under chapter 32 of the General Laws. Prior to appointment under this act, a retired Newton police officer shall pass a medical examination by a physician or other certified professional chosen by the City to determine whether the retired Newton police officer is capable of performing the essential duties of a special police officer under this act, the cost of which shall be borne by the retired Newton police officer.

SECTION 2. Special police officers appointed under this act shall not be subject to chapter 31 of the General Laws, section 99A of chapter 41 of the General Laws, chapter 150E of the General Laws, or chapter 151A of the General Laws. Special police officers appointed under this act shall not be eligible for special leave, vacation or other benefits enumerated in article II of chapter 2 of Newton Revised Ordinances, 2012.

SECTION 3. Special police officers shall, when performing the duties under section 1, have the same power to make arrests and perform other police functions as do regular police officers of the City of Newton.

SECTION 4. Special police officers shall be appointed for an indefinite term, subject to removal by the mayor or the chief of police at any time with a 14 day written notice.

SECTION 5. The workweek for special police officers appointed under this act shall be seven (7) consecutive twenty-four (24) hour periods, for a total of one hundred and sixty-eight (168) hours, which shall commence at 8:00 A.M. at the start of each Monday of the calendar week. In no case shall any special police officer appointed under this act perform police details or any duties arising therefrom in excess of forty (40) hours in any given workweek.

SECTION 6. Special police officers appointed under this act shall be subject to the rules and regulations, policies and procedures and requirements as the chief of police and the mayor of the City of Newton may impose from time to time, including, but not limited to restrictions on the type of detail assignments, requirements regarding medical examinations to determine continuing capability to perform the duties of

a special police officer, requirements for training, requirements for firearms licensing and qualifications and requirements regarding uniforms and equipment. Compliance with all requirements will be at no cost to the City of Newton. Special police officers appointed under this act shall not be subject to section 96B of chapter 41 of the General Laws.

SECTION 7. Special police officers appointed under this act shall be sworn before the city clerk of the City of Newton who shall keep a record of all such appointments.

SECTION 8. Special police officers appointed under this act shall be subject to sections 100 and 111F of chapter 41 of the General Laws. The amount payable under section 111F of chapter 41 shall be calculated by averaging the amount earned over the prior 52 weeks as a special police officer working police details, or averaged over such lesser period of time for any officer designated as a special police officer less than 52 weeks before the incapacity. In no event shall payment under section 111F of chapter 41 exceed, in any calendar year, the limitation on earning contained in paragraph (b) of section 91 of chapter 32 of the General Laws. Payment under section 111F of chapter 41 shall terminate in accordance with section 111F of Chapter 41 or when a special police officer appointed under this act reaches the age of 65, whichever occurs sooner. If the age limitation applicable to regular police officers serving a city is increased from 65 years of age, the termination of benefits under section 111F of chapter 41, as provided in this section for special police officers, shall terminate at such a higher age limit, but in no event shall the benefits extend beyond the age of 70 for any such special police officer. Special police officers appointed under this act shall not be subject to section 85H or 85H 1/2 of chapter 32, nor eligible for any benefits pursuant thereto.

SECTION 9. Appointment as a special police officer does not entitle that person to assignment to any detail.

SECTION 10. Retired Newton police officers serving as special police officers under this act shall be subject to the limitations on hours worked and on earnings restrictions as provided in paragraph (b) of section 91 of chapter 32 of the General Laws.

SECTION 11. This act shall take effect upon its passage.

Under Suspension of Rules
Readings Waived and Adopted
22 yeas 0 nays 2 absent (Aldermen Salvucci and Swiston)

(SGD) DAVID A. OLSON
City Clerk

(SGD) SETTI D. WARREN
Mayor

Date _____

CITY OF NEWTON
IN BOARD OF ALDERMEN

ORDINANCE NO. A-45

September 15, 2014

BE IT ORDAINED BY THE BOARD OF ALDERMEN
OF THE CITY OF NEWTON AS FOLLOWS:

That the Revised Ordinances of Newton, Massachusetts, 2012, as amended, be and are hereby further amended with respect to **Article I of Chapter 24** follows:

Insert a new Sec. 24-6 as follows, and renumber existing Secs. 24-6 through 24-9 accordingly.

Sec. 24-6 Police Retiree Detail Patrol

The mayor may appoint, at the recommendation of the police chief and as the police chief deems necessary, retired Newton police officers as special police officers, to be known as the Newton Police Retiree Detail Patrol, to perform police details or any duties arising therefrom or during the course of police detail work, whether or not related to the detail work, subject to the following requirements and conditions. Special police officers appointed under this section shall be paid for performing assigned details at the same rate as regular police officers performing assigned details.

(a) The retired police officers shall have been regular Newton police officers and retired from Newton based on superannuation. They shall be subject to the same maximum age restrictions as applied to regular Newton police officers under chapter 32 of the General Laws.

(b) Prior to appointment under this section, a retired Newton police officer shall pass a medical examination by a physician or other certified professional chosen by the City to determine whether the retired Newton police officer is capable of performing the essential duties of a special police officer under this section, the cost of which shall be borne by the retired Newton police officer.

(c) Special police officers appointed under this section shall not be subject to chapter 31 of the General Laws, section 99A of chapter 41 of the General Laws, chapter 150E of the General Laws, or chapter 151A of the General Laws. Special police officers appointed under this section shall not be eligible for special leave, vacation, or other benefits enumerated in article II of chapter 2 of these ordinances.

(d) Special police officers shall, when performing the duties under this section, have the same power to make arrests and perform other police functions as do regular police officers of the City of Newton.

(e) Special police officers shall be appointed for an indefinite term, subject to removal by the mayor or the chief of police at any time with a 14 day written notice.

(f) The workweek for special police officers appointed under this section shall be seven (7) consecutive twenty-four (24) hour periods, for a total of one hundred and sixty-eight (168) hours, which shall commence at 8:00 A.M. at the start of each Monday of the calendar week. In no case shall any special police officer appointed under this section perform police details or any duties arising therefrom in excess of forty (40) hours in any given workweek.

(f) Special police officers appointed under this section shall be subject to the rules and regulations, policies and procedures and requirements as the chief of police and the mayor may impose from time to time, including, but not limited to restrictions on the type of detail assignments, requirements regarding medical examinations to determine continuing capability to perform the duties of a special police officer, requirements for training, requirements for firearms licensing and qualifications and requirements regarding uniforms and equipment. Compliance with all requirements will be at no cost to the City of Newton. Special police officers appointed under this section shall not be subject to section 96B of chapter 41 of the General Laws.

(g) Special police officers appointed under this section shall be sworn before the city clerk of the City of Newton who shall keep a record of all such appointments.

(h) Special police officers appointed under this section shall be subject to sections 100 and 111F of chapter 41 of the General Laws. The amount payable under section 111F of chapter 41 shall be calculated by averaging the amount earned over the prior 52 weeks as a special police officer working police details, or averaged over such lesser period of time for any officer designated as a special police officer less than 52 weeks before the incapacity. In no event shall payment under section 111F of chapter 41 exceed, in any calendar year, the limitation on earning contained in paragraph (b) of section 91 of chapter 32 of the General Laws. Payment under section 111F of chapter 41 shall terminate in accordance with section 111F of Chapter 41 or when a special police officer appointed under this section reaches the age of 65, whichever occurs sooner. If the age limitation applicable to regular police officers serving a city is increased from 65 years of age, the termination of benefits under section 111F of chapter 41, as provided in this section for special police officers, shall terminate at such a higher age limit, but in no event shall the benefits extend beyond the age of 70 for any such special police officer. Special police officers appointed under this section shall not be subject to section 85H or 85H 1/2 of chapter 32, nor eligible for any benefits pursuant thereto.

(i) Appointment as a special police officer under this section does not entitle that person to assignment to any detail.

(j) Retired Newton police officers serving as special police officers under this section shall be subject to the limitations on hours worked and on earnings restrictions as provided in paragraph (b) of section 91 of chapter 32 of the General Laws.

Approved as to legal form and character:

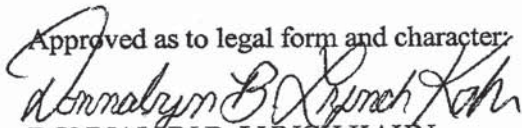
DONNALYN B. LYNCH KAHN
City Solicitor

Under Suspension of Rules
Readings Waived and Approved
22 yeas 0 nays 1 absent (Alderman Lappin) 1 vacancy

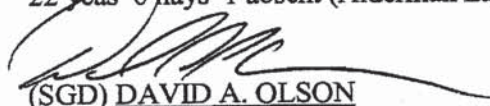
(SGD) DAVID A. OLSON
City Clerk

(SGD) SETH D. WARREN
Mayor

Date: 9/22/14



SETTI D. WARREN
MAYOR

City of Newton, Massachusetts
Office of the Mayor

#218-15
Telephone
(617) 796-1100
Facsimile
(617) 796-1113
TDD/TTY
(617) 796-1089
E-mail
swarren@newtonma.gov

August 31, 2015

Honorable Board of Aldermen
Newton City Hall
1000 Commonwealth Avenue
Newton, MA 02459

RECEIVED
Newton City Clerk
2015 AUG 31 PM 3:08
David A. Olson, CMC
Newton, MA 02459

Ladies and Gentlemen:

I write to request that your Honorable Board docket for consideration a request to authorize the appropriation of \$650,000 and authorize a general obligation borrowing of an equal amount for the purchase of a new Fire Department Pumper Truck listed in the FY2016-FY2020 Supplemental CIP. This truck will replace a 1999 model that exceeds NFPA 15 year life expectancy standards. The older truck will be used as a spare engine in our fleet.

Thank you for your consideration of this matter.

Very truly yours,

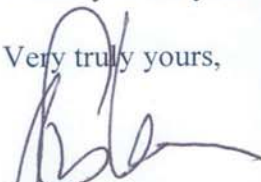

Setti D. Warren
Mayor

1000 Commonwealth Avenue Newton, Massachusetts 02459

www.newtonma.gov



DEDICATED TO COMMUNITY EXCELLENCE



Bruce A. Proia
Chief

CITY OF NEWTON, MASSACHUSETTS
FIRE DEPARTMENT HEADQUARTERS

1164 Centre Street, Newton Center, MA 02459-1584
Chief: (617) 796-2210 Fire Prevention: (617) 796-2230
FAX: (617) 796-2211 EMERGENCY: 911



Setti D. Warren
Mayor

July 16, 2015

Maureen Lemieux
Chief Financial Officer
City Of Newton
1000 Commonwealth Ave
Newton, MA 02459

Maureen,

I respectfully request to docket funding of \$650,000.00 for the purchase of a new Fire Department Pumper Truck. This will replace a 1999 truck that exceeds NFPA 15 year life expectancy. The older 1999 truck will be used as a spare engine in our fleet.

The purchase of this truck is in the CIP for FY2016.

Thank you for your consideration to the request.

A handwritten signature in blue ink, appearing to read "BR".

Bruce Proia
Chief of Department

7/15/2015

E-One EMax - MAPC/FCAM Purchasing Info - Diane DiBona

#218-15

E-One EMax - MAPC/FCAM Purchasing Info

Mark MacDonald <MMacDonald@greenwoodev.com>

Tue 7/14/2015 4:35 PM

To: Diane DiBona <ddibona@newtonma.gov>;

Cc: Bruce A. Proia <bproia@newtonma.gov>; Gino Lucchetti <glucchetti@newtonma.gov>; Mark W. Roche <mroche@newtonma.gov>;

📎 2 attachments (882 KB)

2013MAPC.PUMPERCONTRACT.signedcopy6.14.13.pdf; Greenwood_Pumpers_2015 extension_201412041719.pdf;

Hi Diane,

I completed the MAPC/FCAM program pricing this afternoon for the truck and the total price comes to **\$594,117** with all of the added shelves, tool board, and roll out trays we discussed this morning. All I would need to proceed and get the truck on order would be a purchase order from the City of Newton in that amount.

I have attached a copy of the MAPC/FCAM contract (which can also be found on their website at www.mapc.org) for your review, along with the current contract extension that extends the program until December 31, 2015. If you should need any other information, or if you should have any questions pertaining to the MAPC/FCAM collective procurement program, you can email Heidi Anderson at handerson@mapc.org or Lorraine See at lsee@mapc.org.

Thank you all once again for your consideration of Greenwood and Emergency One! I look forward to working with the Newton Fire Department on this project!

Regards,

Mark

Mark MacDonald
Vice President, Sales
Greenwood Emergency Vehicles, Inc.
(508)809-9810
mmacdonald@greenwoodev.com

GEV.JPG

Check out our website at www.greenwoodev.com



Fire Apparatus Quotation for:
CITY OF NEWTON FIRE DEPT



Quotation Number: 74245 Rev: 13

Unit Description: PMPR-TYPH

Quote Description: Pumper, Typhoon

Salesperson: MMACDONALD

Salescode	Extended Description	Qty
TESTING COMPLIANCE STANDARD		
1001-0015	The E-ONE supplied components of the vehicle shall meet the requirements of NFPA 1901, 2009 edition.	1
BUMPERS		
1160-0000	Bumper 10" stainless steel.	1
1160-0010	1/8" Front Bumper Gravel Shield.	1
1160-0013	16" Front Bumper Gravel Shield Extension.	1
1160-0020	License plate holder mounted center of front bumper.	1
BUMPER TRAYS		
1150-0121	Bumper tray center of bumper with slats 14 inches deep (approx 13 inches to slats).	1
1150-0139-589	Nylon black strap with aluminum quick release buckle for front bumper hose tray. Strap to attach to front and rear walls of tray down low as applicable. Location: center.	1
FRAME ASSEMBLY		
1250-0003	Frame 10.25 x 3.5 x .375 chassis.	1
1250-0011	Rear underbody support frame.	1
1250-0068	Chassis frame rails, front frame extensions, rear subframe (Urban Interface), crossmembers and battery brackets shall be zinc plated (galvanized) IPOS.	1
AXLE OPTIONS		
1025-0005	Meritor FL-941 front axle 18,700 lb.	1
1025-0017	Meritor RS-25-160 single rear axle 27,000 lb. capacity.	1
1025-0028	Koni shock absorbers for front axle - adjustable.	1

Salescode	Extended Description	Qty
SUSPENSIONS		
1070-0027	Rear suspension FIREMAAX EX model FMX-272 27,000 lb. single axle air ride.	1
WHEEL OPTIONS		
1050-0001	Alcoa aluminum wheels for front axle (2).	1
1050-0003	Alcoa aluminum wheels for rear axle (4).	1
1050-0007	Front axle wheel trim kit. Includes stainless steel lug nut covers (chrome plated plastic if applicable) and center cap with E-ONE logo. Note: Center cap will have an inspection port IPO a logo if equipped with Stemco oil seals.	1
1050-0008	Rear axle (single) wheel trim kit. Includes stainless steel lug nut covers (chrome plated plastic if applicable) and center cap with E-ONE logo. E-ONE custom chassis w/steel wheels will have chrome plated plastic lug covers.	1
TIRE OPTIONS		
1060-0016	Four Michelin 12R rear tires with XDN2 mud and snow tread.	1
1060-0047	Two Michelin 385 tires model XFE for front axle.	1
1060-0117	RWC AirGuard LED tire pressure monitoring valve stem caps (6) for single rear axle applications.	1
BRAKE SYSTEMS		
1100-0001	Meritor EX225H 17" disc brakes for front axle.	1
1100-0002	ArvinMeritor 16-1/2" x 7" S-cam brakes with cast brake drums for a single rear axle.	1
1100-0005	Brake system air 4X2/4X4.	1
1100-0006	Parking brake release mounted on the driver's side lower dash.	1
1100-0024	G4 Electronic Stability Control (4x2), Includes RSC and ATC. Not available on 4x4, commercial chassis or tiller.	1
AIR SYSTEM OPTIONS		
1110-0000-001	Inlet for air system. Location: driver door jamb.	1
1110-0002	Air dryer Bendix AD-9.	1
1110-0006	Air lines nylon.	1
1110-0041	Air horns Grover recessed in bumper (PR).	1
ENGINES & TRANSMISSIONS		
1200-0017	Push-button transmission shift selector.	1
1200-0020	TransSynd synthetic transmission fluid for EVS3000.	1

Salescode	Extended Description	Qty
ENGINES & TRANSMISSIONS		
1200-0097	Electronic limiting of speed to 68 MPH maximum. Note: Max speed may be set at 65 MPH due to tire rating.	1
1200-0236	Eng/Trans Cummins ISL 450HP/EVS3000 2013 EPA compliant engine.	1
SECONDARY BRAKING		
1125-0002	Jacobs engine compression brake.	1
1125-0023	Transmission to seek second gear when Jacobs engine brake or Telma retarder is engaged. N/A with Trans retarder.	1
EXHAUST OPTIONS		
1680-0021	Exhaust end for Plymvent. For exhaust extraction system.	1
COOLING PACKAGE		
1800-0013	Cooling system for use with Cyclone II X, Typhoon X, and Quest chassis. For use with 2010/2013 EPA engines. Includes coolant recovery system.	1
FUEL SYSTEMS		
1350-0003	Fuel system 50 gallon.	1
1350-0009	Fuel line hose braided.	1
1350-0012-669	Fuel shut-off valve. Location: one (1) at fuel tank.	1
ALTERNATOR		
1700-0005	Alternator Leece Neville 320 amp. 320 amp SAE/275 amp NFPA.	1
BATTERIES		
1400-0002	Battery four group 31 1000 CCA.	1
CHASSIS OPTIONS		
1680-0005	Thermatic fan clutch.	1
1680-0006	Drivelines 1710.	1
1680-0008	Tow eyes front painted below bumper/cab (PR).	1
1680-0011	Tow eyes rear below body, painted.	1
1680-0022	Auto lube system Vogel. Chassis points only.	1
1680-0250-M58	Diesel Exhaust Fluid (DEF) 5 gallon tank for 2013 EPA engines. Location: left side below rear of cab.	1
1680-0284	Radiator mounted power steering cooler.	1
CAB MODEL		

Salescode	Extended Description	Qty
CAB MODEL		
1520-0025	Typhoon X medium cab with 58" CA. Includes barrier style doors.	1
CAB ROOF TYPE		
1615-0001	Vista full height rear doors, 12".	1
1615-0006	Delete side vista roof windows ahead of rear doors.	1
1615-0007	Delete rear vista roof windows.	1
1615-0009	Delete upper rear door vista roof windows	1
CAB BADGE PACKAGE		
1610-0000	Cab and body to have applicable E-ONE logos.	1
GRILLE		
1620-0006	CIIX stainless steel grille for Typhoon X.	1
CAB DOOR OPTIONS		
1550-0003	Rear crew cab doors in the medium position.	1
1550-0006	Driver and officer cab door windows. Include rear fixed window.	1
1550-0015	Stainless steel protective trim on rear edge of cab door openings. E-ONE custom chassis only.	1
1550-0017	Cab door panels stainless steel.	1
1550-0024	All cab doors shall have exterior paddle latches.	1
1550-0027	Front cab door windows to have manual actuation.	1
1550-0077	Interior cab door locks - manual. Will have manual actuation from each respective door. Includes barrel style key lock on each exterior cab door.	1
1550-0084	All cab exterior access doors to have 1250 keyed locks.	1
1550-0103	Rear crew cab door windows with rear fixed panel. Includes manual roll-down actuation. For use with paddle style door latching.	1
1550-0177-000-17	Red/Fluorescent Yellow Green Reflexite V98 striping positioned in the "A" formation located on the cab door panels.	1
1550-0186-658	(4) TecNiq T440 4" LED cab step area lighting. Locate each light in the cab step well area. Lights to be switched with door ajar.	1
MIRRORS		
1670-0015	Velvac 2010 mirrors with marker lights. Door mounted west coast style with remote control and heat.	1
MISC EXTERIOR CAB OPTIONS		

Salescode	Extended Description	Qty
MISC EXTERIOR CAB OPTIONS		
1550-0020	Windows cab side fixed driver's side.	1
1550-0033	Windows cab side fixed officer's side.	1
1675-0022	Pair of 18" handrails located just behind driver and officer front door one each side.	1
1675-0024	Pair of 36" handrails located just behind driver and officer rear door (ALS doors if equipped) one each side.	1
1675-0030	Mud flaps, front, black with E-ONE logo.	1
1675-0047	Rear cab wall to be 3/16" aluminum diamond plate.	1
1675-0202	Mounting plate for battery charger receptacle, indicator and air inlet (if applicable). Plate to be removable brushed stainless steel.	1
HVAC		
1515-0017	Air conditioning for the Typhoon X, CII X and Quest with Cummins ISC/ISL engine and radiator mounted condenser.	1
1515-0053	Controls for heating and air conditioning shall be located in the center dash area. (Lower area on Typhoon and CII with severe duty dash)	1
1685-0057	Heaters cab rear with covers (PR), and front heater with heat to the feet for the driver and officer.	1
SEATS		
1510-0004	Seats, Bostrom brand.	1
1510-0008	Seat color gray.	1
1510-0037	Seat cover material Durawear.	1
1510-0046	Officer seat to be Bostrom air ride SCBA.	1
1510-0049	Driver seat to be Bostrom electric.	1
1510-0057	Rear facing Bostrom seat with SCBA officer's side.	1
1510-0063	Two man bench centered on rear wall with Bostrom SCBA. Includes angled corners.	1
1510-0117-147	Bostrom SecureAll mechanical air pack bottle bracket (EA). Location: officer's seat.	1
1510-0117-215	Bostrom SecureAll mechanical air pack bottle bracket (EA). Location: rear facing officer's side.	1
1510-0131-151	Bostrom SecureAll mechanical air pack bottle bracket (EA) for bench / fold-down seat. Location: inboard driver's side rear wall.	1
1510-0131-152	Bostrom SecureAll mechanical air pack bottle bracket (EA) for bench / fold-down seat. Location: inboard officer's side rear wall.	1

Salescode	Extended Description	Qty
SEATS		
1510-0279-146	Ready/Reach seat belt extender. Location: driver's seat.	1
1510-0279-147	Ready/Reach seat belt extender. Location: officer's seat.	1
1510-0279-151	Ready/Reach seat belt extender. Location: inboard driver's side rear wall.	1
1510-0279-152	Ready/Reach seat belt extender. Location: inboard officer's side rear wall.	1
1510-0279-215	Ready/Reach seat belt extender. Location: rear facing officer's side.	1
1685-0032	Seating capacity tag of five occupants.	1
MEDICAL CABINETS		
1535-0012	Medical cabinet mounted on the wheel well driver side of cab 45H x 21W x 24D with a locking roll-up door.	1
1535-0030	All roll-up medical cabinet doors selected on the cab to be ROM brand.	1
1535-0032	All medical cabinet RUD in the cab to be locking with 1250 key	1
1535-0202	Cab medical/storage cabinet(s) finish to be Zolatone gray. Includes interior/exterior of cabinet and shelves/trays if equipped.	1
MAP BOXES		
1540-0013	All map boxes in the cab to be painted Zolatone 20-64 gray.	1
1540-0029	Offset suspended map box to rear of vertical 3x3 extrusions and as low as possible. Front of map box flush with front of 3x3 uprights.	1
1540-0051	Map box suspended with drop-down doors. 34"W x 9.50"H x 12"D.	1
MISC INTERIOR CAB OPTIONS		
1680-0053	Storage below rear bench seat. (1) hinged door on each side of the bench seat.	1
1685-0000	Cab interior gray. Does not include engine cover or seat color.	1
1685-0005	Lexan sun visors, driver and officer's side overhead.	1
1685-0008	Control lanyard Y type for air horns.	1
1685-0187	Severe duty engine cover, molded polyurethane.	1
1685-0193	Slide-out MDT mount officer cab dash. Requires severe duty dash w/MDT notch.	1
1685-0369	Severe duty dash package with low profile officer side dash. Includes smooth plate alum center and officer side dash and lower kick panels; all painted to match cab interior.	1
CAB ELECTRICAL OPTIONS		
1750-0022	Battery charger Kussmaul 40 amp model 1200 with air compressor.	1
1750-0026	Clamshell controller mounted on officer's side of engine cover for the air horns.	1

Salescode	Extended Description	Qty
CAB ELECTRICAL OPTIONS		
1750-0046-195	Cab Headlights. Position: lower.	1
1750-0059-R60-02	Receptacle inlet 20 amp with a Red cover. Location: driver's seat riser (outboard) relocate riser door to the front wall of riser.	1
1750-0063	Clamshell controller mounted on officer's side of engine cover for Q2B.	1
1750-0064	Clamshell controller mounted on on officer's side of engine cover for electronic siren.	1
1750-0072-593	12 VDC (or 24VDC) electrical outlet in the cab wired battery hot. Location: officer side dash.	1
1750-0073-585	Antenna base Tessco P/N 90942 (NMO Motorola Style - also called MATM style) on cab roof. Location: driver side forward with coaxial cable terminating at the center of the dash board.	1
1750-0073-844	Antenna base Tessco P/N 90942 (NMO Motorola Style - also called MATM style) on cab roof. Location: officer side forward with coaxial cable terminating at the center of the overhead console.	1
1750-0075	English dominant main cab gauge cluster.	1
1750-0078	Light Whelen model PSR00FRR LED (4) red. Horizontal mounted flashing strip light on each of the inside lower cab door panels. Wire through door switch.	1
1750-0158	Dome Lts Red/White LED. Package includes two lights mounted in the front and two mounted in the rear of the cab. White light wired through door and light assembly switch. Red light through light assembly switch.	1
1750-0166	ATC override switch.	1
1750-0188	DPF regeneration override switch.	1
1750-0198-762	Battery charger to be located behind officer's seat.	1
1750-0199-762	Air compressor to be located behind officer's seat.	1
1750-0215-172	Turn signal Whelen M6 LED arrow amber pair located upper headlight bezel.	1
1750-0429-593	Dual USB charging ports in the cab wired battery hot. Location: officer side dash.	1
1750-0435	Halogen cab headlights. TyphoonX, CIIX and QST2 only.	1
BODY COMPT LEFT SIDE		
3100-0116	Driver side body with full height 42" wide forward and 42" wide rearward compartmentation. Includes (1) 56" wide compartment over the wheel well.	1
BODY COMPT RIGHT SIDE		
3120-0193	Officer side body with full height 42" wide forward and 42" wide rearward compartmentation. Includes (1) 56" wide compartment over the wheel well and one (1) storage tunnel.	1

Salescode	Extended Description	Qty
BODY COMPT REAR		
3110-0013	Full Height Rear Compartment with Officer Side Storage Tunnel. Includes smooth plate panels and storage access door with push button latch.	1
3340-0080	Bolt-on diamond plate 18" tailboard (full width of body). Includes (2) squared off beaverails (no stanchions) with removable outer panels and handrails- (2) vertical on trailing edge of body and horizontal mounted handrail(s) below hosebed.	1
DOORS		
3300-0019-027	Door roll up tall (greater than 45") with satin finish ROM. Location(s): B1.	1
3300-0021-004	Door roll up short (up to 45") with painted finish ROM. Location(s): L2.	1
3300-0021-016	Door roll up short (up to 45") with painted finish ROM. Location(s): R2.	1
3300-0141-003	Tri-Mark door latch. Location(s): L1.	1
3300-0141-005	Tri-Mark door latch. Location(s): L3.	1
3300-0141-015	Tri-Mark door latch. Location(s): R1.	1
3300-0141-017	Tri-Mark door latch. Location(s): R3.	1
3300-0167-003	Door double 3-point vertical hinged w/rotary latches - painted. Location(s): L1	1
3300-0167-005	Door double 3-point vertical hinged w/rotary latches - painted. Location(s): L3	1
3300-0167-015	Door double 3-point vertical hinged w/rotary latches - painted. Location(s): R1	1
3300-0167-017	Door double 3-point vertical hinged w/rotary latches - painted. Location(s): R3	1
SHELVES		
3370-0052-003	Adjustable shelf (J-Style) for non-transverse compartments 16" or greater in depth. Location: L1.	1
3370-0052-004	Adjustable shelf (J-Style) for non-transverse compartments 16" or greater in depth. Location: L2.	1
3370-0052-073	Adjustable shelf (J-Style) for non-transverse compartments 16" or greater in depth. Location: R1 lower.	1
3370-0053-016	Adjustable shelf (C-Style) for non-transverse compartments up to 15.99" in depth. Location: R2.	1
3370-0053-074	Adjustable shelf (C-Style) for non-transverse compartments up to 15.99" in depth. Location: R1 upper.	1
3370-0053-076	Adjustable shelf (C-Style) for non-transverse compartments up to 15.99" in depth. Location: R3 upper.	1
3370-0054-003	Tracks for adjustable shelf and/or adjustable tray in compartments 16" or greater in depth. Location: L1.	1
3370-0054-004	Tracks for adjustable shelf and/or adjustable tray in compartments 16" or greater	1

Salescode	Extended Description	Qty
SHELVES		
	in depth. Location: L2.	
3370-0054-073	Tracks for adjustable shelf and/or adjustable tray in compartments 16" or greater in depth. Location: R1 lower.	1
3370-0055-016	Tracks for adjustable shelf in shallow compartments up to 15.99" deep. Location: R2.	1
3370-0055-074	Tracks for adjustable shelf in shallow compartments up to 15.99" deep. Location: R1 upper.	1
3370-0055-076	Tracks for adjustable shelf in shallow compartments up to 15.99" deep. Location: R3 upper.	1
TRAYS / TOOLBOARDS		
3380-0076-003	Tray, floor mounted roll-out with gas spring. 500 lbs. capacity. Location: L1.	1
3380-0076-015	Tray, floor mounted roll-out with gas spring. 500 lbs. capacity. Location: R1.	1
3380-0076-017	Tray, floor mounted roll-out with gas spring. 500 lbs. capacity. Location: R3.	1
3380-0076-027	Tray, floor mounted roll-out with gas spring. 500 lbs. capacity. Location: B1.	1
3380-0079-005	Adjustable heavy duty tool board with 500 lbs. capacity. Includes return style reinforcing bends on vertical front and rear edges of tool board, upper and lower adjustable track and gas shock actuated. Tool board sized to compartment height and depth as applicable. Location(s): L3.	2
COVERS		
3305-0003	Single diamond plate cover for the crosslay area. Includes applicable grab handle(s) and (2) hold downs. Non-aerial applications to be tagged as a non-stepping surface.	1
3305-0004	Crosslay cover to be hinged forward.	1
3305-0023	Nylon black cargo net at rear of diamond plate or vinyl hose bed cover or similar.	1
3305-0025	Nylon black cargo net on sides for crosslay cover.	1
3305-0119	Hold open device(s) for aluminum crosslay (single or bi-fold) cover. Locate as required based off options on module.	1
3305-0219	(2) piece light weight aluminum hose bed cover. Includes center hose bed divider with notched rear (as applicable), fill tower(s) access door(s) (as applicable), gas shocks, positive hold opens/hold closed at rear, (2) grab handles front and (2) hand rails rear.	1
PUMP MODULE		
168683	Pump module modification for lowered crosslays accessed from the ground. Front headboard of module to be lowered and provisions added to mount crosslay cover forward of deck gun channel. See body layout.	1

Salescode	Extended Description	Qty
PUMP MODULE		
3130-0167	Pump module to be 76" wide (side to side). Includes upper, lower, crosswalk, speedlay and tranverse module(s) if applicable.	1
3130-0523	Side mount pump module. Extruded aluminum with runningboards.	1
3130-0535	Pump panel opening is 57" wide. Pumper / tanker only.	1
3130-0540	Pump module height is 80". Pumper / tanker only.	1
PUMP PANELS		
3134-0006	The single gauge panel on the driver's side of the side mount module is to be hinged downward. Includes two (2) cable hold opens, and latches.	1
3134-0016	Stainless steel driver and officer side pump panels.	1
3134-0055	Officer side upper pump access panel to be horizontal hinged with stainless steel door. Includes (2) push button latches and (2) hold open devices.	1
MISC PUMP PANEL OPTIONS		
168685	Air outlet with Innovative Control 1/4" valve w/1/4 turn "T" handle w/label and 25' hose. Location: driver side	1
4460-0003	Pump panel tags color coded per NFPA compliance.	1
PUMP MODULE OPTIONS		
3136-0000-202	Air horn switch at pump panel. Switch to be labeled "Evacuation Alert". Location: driver side pump panel.	1
3136-0011	P-Rubber in flex joint(s) between pump module and/or body modules.	1
3136-0058	E-ONE logo mounted one each side on pump module/preconnect panels. Logos to be sized as applicable to available space on panels.	1
3136-0138	Pump module storage pan.	1
3136-0140	Crosslay double 7.5" wide each with extra depth to hold up to 400' of 2.0" DJ hose (each).	1
WATER TANK		
4010-0177	780 Gallon "R" Water Tank. UPF Poly III color fill towers. Note: Any foam cell(s) and/or storage options through the tank will reduce the overall water capacity.	1
4010-0223	Fill tower(s) to be located offset to driver side of water tank.	1
TANK PLUMBING		
4450-0010	2" tank fill Akron manual valve.	1
4450-0119	3" tank to pump Akron manual valve w/4" tank connection.	1
FOAM TANK		

Salescode	Extended Description	Qty
FOAM TANK		
4100-0033-591-04	30 gallon integral foam tank for Class B foam. UPF Poly III Yellow fill tower. Foam tank capacity will reduce the water tank capacity.	1
FOAM TANK OPTIONS		
4110-0002-202	Foam tank (B) outlet. Includes 1" male adapter and connector (ship loose). Outlet location: driver side pump panel.	1
LADDER STORAGE / RACKS		
3365-0028	Hard Suction Storage Rack. Driver side compartment top. Includes spring hold downs and scuff plates behind spring mounts (as applicable).	1
3365-0035	Hard Suction Storage Rack. Officer side compartment top. Includes spring hold downs and scuff plates behind spring mounts (as applicable).	1
3365-0050	Brand of ladders capable of being carried on unit to be Duo-Safety.	1
3365-0087-Z71	The length of ladders capable of being stored shall be the following: 24' 2-section, 14' roof ladder and 10' attic ladder w/shoes.	1
3365-0149-097	Storage tunnel capable of holding: (1) 2-section, (1) roof, (1) attic, (2) pike poles, (1) backboard in Officer side storage tunnel.	1
HANDRAILS / STEPS		
3330-0012	Intermediate pump panel step officer side with forward tapered corner. Includes step lighting (as applicable). Step light to be switched thru work light in cab.	1
3330-0034	Recessed folding step box. Driver side rear. To accommodate all steps as applicable.	1
3330-0035	Recessed folding step box. Officer side rear. To accommodate all steps as applicable.	1
3330-0073	Step rear intermediate. Locate above B1, includes handrail (in place of horizontal hosebed handrail).	1
3330-0103	Dual lighted LED folding steps rear NFPA. Includes folding steps on driver side (staggered stepped as applicable with tailboard depth) for NFPA hosebed access and handrail mounted on driver side upper hosebed side (as applicable).	1
3330-0104	Dual lighted LED folding steps rear NFPA. Includes folding steps on officer side (staggered stepped as applicable with tailboard depth) for additional hosebed access and handrail mounted on officer side upper hosebed side (as applicable).	1
3330-0105-060	Dual lighted LED folding step. Location: officer side front compartment face. Each location requires a minimum of (1) handrail per NFPA.	4
3330-0105-062	Dual lighted LED folding step. Location: driver side front compartment face. Each location requires a minimum of (1) handrail per NFPA.	4
MISC BODY OPTIONS		

Salescode	Extended Description	Qty
MISC BODY OPTIONS		
3090-0002	OAH. Unit has no overall height restrictions.	1
3090-0004	OAL. Unit has no overall length restrictions.	1
3090-0006	The hose bed is to have the capacity for the following hose. Hose load shall be listed from driver to officer.	1
3340-0004	Hosebed above the booster tank. Includes forward hosebed and tower(s) cover plate work (as applicable). Hosebed adjustable divider extrusion rearward of the furthest tower is to run full width of the hosebed (as is practical with other hosebed mounted equipment).	1
3340-0015	Diamond plate single axle wheel well. Includes bolt-on composite wheel well liners and aluminum trim fenderettes.	1
3340-0035	Divider Long. To run full length of hose bed (front to rear).	2
3340-0058	Recessed fuel fill driver side wheel well.	1
3340-0074	Body mainframe and hosebed side assemblies for a 85" high body.	1
3340-0089-000-13	Turtle Tile Brand Black Floor Matting covering all applicable Compartment Floors, Shelves, and Rollout Trays.	1
3340-0093	Mud flaps, rear, black with E-ONE logo.	1
3340-0110	The rear of each hose bed divider to have a hand hold cut-out(s).	1
3340-0125	Recess mounting for directional light bar. Located on rear area of body.	1
3340-0145	Rub rail for the body and pump area module(s).	1
3340-0681	Body mainframe layout line to be 24". Includes body and all applicable modules.	1
SCBA BOTTLE STORAGE		
3320-0007	SCBA Bottle Storage. (7) E-ONE SCBA bottle storage with hinged doors (doors to match wheel well material) with push button latches. (4) officer side and (3) driver side in wheel well area.	1
3320-0100	Strap(s), loop style to retain SCBA bottle(s). Locate one per bottle in each exterior storage compartment.	7
PUMPS		
4005-0013	Hale QFLO 750-1250 GPM pump, single stage.	1
4005-0030	Rating 1250 GPM	1
PUMP CERTIFICATION		
4475-0000	Pump certification 750-2250 GPM	1
PUMP OPTIONS		

Salescode	Extended Description	Qty
PUMP OPTIONS		
4015-0008	Zinc anodes for Hale pump (PR), (1) discharge side and (1) intake side.	1
4015-0012	Pump shift override, side panel mounted.	1
4015-0014	Thermal Relief Valve - Hale TRV120.	1
4015-0053-198	Steamers to be Flush + 1". Location: driver's side.	1
4015-0053-199	Steamers to be Flush + 1". Location: officer's side.	1
4015-0098	Manual operated master pump drain. The master drain shall be clearly marked and placed in accessible location on pump panel.	1
4015-0210	Pump cooler with Innovative Control 1/4 turn valve with "T" handle and label.	1
INTAKES		
4440-0005	2.5" Left Intake Akron Manual Valve.	1
INTAKE OPTIONS		
4445-0009	Intake relief valve, Akron.	1
DISCHARGES AND PRECONNECTS		
4415-0008	1.5" front bumper discharge Akron manual valve.	1
4415-0012-654	1.5" Crosslay with Akron manual valve. Location: crosslay 1 & 2.	2
4415-0022-350	2.5" Left Rear Discharge Akron Manual Valve. Location: left rear discharge.	1
4415-0022-678	2.5" Left Rear Discharge Akron Manual Valve. Location: left rear discharge 2 (inboard or below).	1
4415-0041	3" Deck Gun Discharge, Akron manual valve.	1
4415-0054-583	4" Right Pump Panel Discharge with 3" Akron Manual Valve (Waterous pumps noted location to be forward lower port). Location: right side discharge 1.	1
4415-0161-581	2.5" Left Panel Discharge Akron Manual Valve w/30 Degree Chrome Droop. Location: left side discharge 1.	1
4415-0161-582	2.5" Left Panel Discharge Akron Manual Valve w/30 Degree Chrome Droop. Location: left side discharge 2.	1
4415-0164-584	2.5" Right Panel Discharge Akron Manual Valve w/30 Degree Chrome Droop. Location: right side discharge 2.	1
4415-0178-532	Polished Stainless Steel Swivel Located on Top of Bumper officer's side of center tray for Front Bumper Discharge.	1
4417-0106-L65	Deck gun piping to be positioned centered in deck gun channel.	1
DISCHARGE OPTIONS		
4417-0175	Innovative Controls push/pull valve controls with locking T handles.	1

Salescode	Extended Description	Qty
DISCHARGE OPTIONS		
4417-0177	Innovative Controls 3/4" bleeder/drain valve include 1/4 turn T-handle.	10
4417-0185	Innovative Controls discharge and intake bezels with integral color code and verbiage for side mount pump panel.	1
PRESSURE GOVERNORS		
4465-0005	Class 1 Captain pressure governor.	1
GAUGES		
4435-0010	Fire Research TankVision model WL2000 water tank level gauge.	1
4435-0011	Fire Research TankVision model WL2700 B foam tank level gauge.	1
4435-0178	Engine gauge package at the pump operator's panel.	1
4435-0244	2.5" Innovative Controls brass case pressure gauge (0-400) with color code bezel.	10
4435-0254	4" Innovative Controls brass case master pressure gauges with bezel. Intake 30-0-400, and discharge 0-400.	1
FOAM SYSTEMS		
4430-0047-556	125 GPM Akron foam eductor. Location: 1.5 first crosslay.	1
4430-0079	The foam system performance shall be tested and certified in compliance with 2009 NFPA 1901.	1
FOAM SYSTEM OPTIONS		
4432-0054-556	Akron Quick Disconnect Foam Pickup Tube on Driver's Side Pump Panel for Eductor. Located on: 1.5 first crosslay.	1
ELECTRICAL SYSTEMS		
5010-0036	V-MUX Electrical system for pumper / tanker / rescue.	1
5010-0049	Vehicle data recorder - 2009 NFPA compliant. Includes occupant detection shown in multiplex display. E-ONE chassis only.	1
5010-0055-649	Vista IV display for V-MUX electrical system. Location: driver's side engine cover.	1
LIGHT BARS		
5300-0158	Light bar Whelen Freedom model FN72QLED 72" LED with 3M Opticom, clear lenses and MKEZ7 mounts. N/A INTL Chassis. Location: Centered on the front cab roof.	1
WARNING LIGHT PACKAGES		
5550-0173-535	Whelen M6 Super LED lower level warning light package. Includes (8) red M6R LED light heads and (2) red M2R LED light heads. Locate side facing lights: at	1

Salescode	Extended Description	Qty
WARNING LIGHT PACKAGES		
	forward most position, centered in rear wheel well, and side facing at rear of body in rubrail if equipped.	
WARNING LIGHTS		
5600-0105-170	Hazard (door ajar) light 2" LED. Location: center overhead.	1
5600-0118-742	Warning light Whelen 500 series TIR6 Super LED (PR) red. Surface mounted 5TSMAC bezel with weatherproof connector. Location: (1) each side in pump module rubrail if equipped.	1
5600-0139-479-06	Whelen beacon with LED upper beacon and 700 series Super LED (PR) model B6LED with red LEDs/clear domes and Red LEDs/clear lenses. Location: rear upper body on aerial style brackets.	1
5600-0241-457	Warning light Whelen M6R series Linear Super LED (PR) red. Location: (1) each side of body rear facing up high.	1
DIRECTIONAL LIGHT BARS		
5310-0017	Whelen Traffic Advisor model TAL65 LED - 36" long.	1
5310-0020-846	Directional light bar control is to be located in the center overhead console offset to driver side.	1
5310-0025	Directional light circuit wiring through upper level warning.	1
SIRENS		
5500-0009	Federal PA300 electronic siren recessed mounted.	1
5500-0011-211	Federal Q2B siren - Pedestal mounted on bumper. Location: officer side front bumper.	1
5500-0024-847	The electronic siren control is to be located on the center overhead console offset to officer side.	1
SPEAKERS		
5510-0029-211	Speaker, Federal Signal Dynamax ES100 with "E-ONE" grille through bumper. Location: officer side front bumper.	1
DOT LIGHTING		
5150-0017	License plate light LED with chrome housing located at the rear of the body.	1
5150-0025	Marker light LED body/cab package. E-One custom cab and pumper or tanker body only.	1
5150-0032	Bracket license plate at rear of body.	1
5150-0091	Whelen M6 series LED vertical mount tail lights. Includes LED stop/tail, arrow turn and back-up lights with vertical 4 light housing and weatherproof connectors.	1

Salescode	Extended Description	Qty
LIGHTS - COMPARTMENT, STEP & GROUND		
5380-0077	Compartment light package Amdor Luma-Bar LED for medium bodies. Includes one light per compartment (two if transverse).	1
5380-0111	Compartment light Amdor LED for medical cabinet (EA).	1
5380-0182	Ground light package EON LED - large.	1
LIGHTS - DECK AND SCENE		
5390-0000-395	Deck light - Unity 12 volt (PR). Location: rear body/beavertail area on the trailing edge up high.	1
5390-0002	Hose bed light Federal Signal GH Scene. Locate at the front area of hose bed. Switched with work light switch in cab.	1
5390-0005	Crosslay light deck Unity. Locate to rear of crosslay (SM) or forward of crosslay (TM).	1
5390-0007	Deck/scene light circuit wiring through chassis reverse. Requires rear deck or scene light.	1
5390-0025	Cab scene lights are to be switched with cab doors in addition to standard.	1
5390-0036	Hose bed light circuit wiring through chassis reverse. Requires hose bed light.	1
5390-0087-396	Whelen M6 Linear Super LED scene lights (PR). Switched in cab (lights mtd on the sides of apparatus to be switched separately). Locate (1) each side rear compartment face up high.	1
5390-0087-397	Whelen M6 Linear Super LED scene lights (PR). Switched in cab (lights mtd on the sides of apparatus to be switched separately). Locate (1) each side of cab, rearward of forward doors, up high.	1
LIGHTS - NON-WARNING		
5400-0003	Engine compartment light (EA).	1
5400-0008	(1) pump panel light over the pump control area to be wired to come on when pump shift is placed in pump. (Side mount forward light noted, Top Mount is center light.)	1
5400-0011	LED pump compartment light (EA).	1
5400-0065-166	Map light, Littlite 18" flexible LED. Location: at officer's A post.	1
5400-0150	Pump panel LED light package for side mount. Includes (6) Tecniq EON lights with S/S housings located (3) ea side. Includes S/S light shields.	1
CONTROLS / SWITCHES		
5100-0001-D46	Switch circuit three way. Includes (1) additional switch. An additional switch required for more than two locations. Location: officer's side switch panel for cab scene lights.	2

Salescode	Extended Description	Qty
CONTROLS / SWITCHES		
5100-0011-T25	Switch 12V for 120-240V (EA). Location: officer's side switch panel for driver's side cab/body 120/240V scene light(s).	1
5100-0011-T26	Switch 12V for 120-240V (EA). Location: officer's side switch panel for officer's side cab/body 120/240V scene light(s).	1
MISC ELECTRICAL		
1750-0082-763	12V power distribution module. Includes (6) battery hot and (6) switched hot circuits. 100 amps max (IATS). Location: rear wall of driver side medical compartment up high.	1
5110-0004	Alternating flasher for headlights.	1
5110-0017	Back-up alarm 97 dB.	1
5110-0065	Lighted bumper guide (PR). Bores model 848211 located (1) each side of front bumper extension.	1
GENERATOR		
5250-0040-122	Generator Harrison 6KW MCR hydraulic. Includes generator control / PTO engage switch and a gauge panel located adjacent to breaker box. Generator location: dunnage pan offset to officer side.	1
GENERATOR TEST		
5255-0001	3rd party generator test with pump.	1
BREAKER BOXES		
5200-0000-394	Breaker box 8 place single phase. Includes main breaker. Note: Main breaker occupies 2 places leaving 6 available. Locate L1 forward wall.	1
LIGHTS - QUARTZ		
5450-0122-437	Light Whelen Pioneer Plus model PFP2 12V with brow mount (EA). Includes switch in cab accessible to driver (driver and officer side facing lights switched separately). Location(s): driver and officer side front cab brow.	2
5450-0122-493	Light Whelen Pioneer Plus model PFP2 12V with brow mount (EA). Includes switch in cab accessible to driver (driver and officer side facing lights switched separately). Location(s): driver and officer side over rear cab door.	2
5450-0261-063	Light Whelen Pioneer model PFP2AC 120V with external bottom raise pole mount. Location(s): officer side back of cab.	1
5450-0261-064	Light Whelen Pioneer model PFP2AC 120V with external bottom raise pole mount. Location(s): driver side back of cab.	1
RECEPTACLES		
5470-0000-730	Receptacle twist lock 15A/110V 3 wire NEMA L5-15 with cover plate. Location: L1	1

Salescode	Extended Description	Qty
RECEPTACLES		
5470-0000-731	up high rearward side wall. Receptacle twist lock 15A/110V 3 wire NEMA L5-15 with cover plate. Location: R1 up high rearward side wall.	1
5470-0004-545	Receptacle household 20A/110V duplex 3-prong NEMA 5-20 with cover plate interior mounted wired to inlet receptacle. Location: In cab driver side on 3 x 3 post rear facing just above engine cover.	1
5470-0004-546	Receptacle household 20A/110V duplex 3-prong NEMA 5-20 with cover plate interior mounted wired to inlet receptacle. Location: In cab officer side on 3 x 3 post rear facing just above engine cover.	1
REDUCERS		
7300-0000	Reducer Chrome 2.5"FNST x 1.5"MNST.	5
GROUND LADDERS		
7800-0003	10' folding Duo-Safety 585-A ladder.	1
7800-0008	14' roof ladder, Duo-Safety 775-A.	1
7800-0018	Extension ladder, Duo-Safety 900-A, 24' 2-section.	1
MISC LOOSE EQUIPMENT		
7600-0016	Wheel chocks 44" NFPA compliant, pair (PR) of Zico SAC-44. Up to 44" diameter tires. Includes mounting brackets.	1
7900-0014	DOT Required Drive Away Kit - Kit includes three (3) triangular warning reflectors with carrying case. This kit is for the end user and is to remain with the truck.	1
EXTERIOR PAINT		
8100-0064	Cab paint break - standard with dip to grille. Break is 31.5" inches below the drip rail on Typhoon X and CII X cabs. Pre-07' emission Typhoon cab break is 33.5" below the drip rail.	1
8100-0089	All applicable pump/pre-connect application modules are to have a sanded finish (not painted job color). Includes upper and lower pump modules, crosswalk module and/or speedlay/pre-connect module (as applicable). Rear mounted body/pump module to be painted job color.	1
8100-0116	Rear body surface to have a sanded finish (not painted job color). Includes hinged doors that do not have discrete sales codes and removable panels.	1
8100-0176-000-81	Paint E-ONE chassis cab - Sikkens paint. Color: FLNA3051 Red.	1
8100-0177-000-A2	Paint cab Sikkens two-tone. Upper area of cab to be painted FLNA4040 White.	1
8100-0182-000-81	Paint Body - Small - For Pumps, Rear Mounts, S/A Tankers/Wetsides and Rescues. Sikkens paint. Color: FLNA3051 Red.	1

Salescode	Extended Description	Qty
INTERIOR PAINT		
8150-0011	The interior of the cab to be painted Zolatone gray.	1
STRIPING		
8300-0001	NFPA required reflective striping to be dealer/customer applied.	1
8300-0042	White rubrail scotchlite insert.	1
8300-0071-000-13	Paint break Scotchlite chassis stripe - 3/4" Wide - Black. To be located at existing paint break.	1
8300-0274-000-37	Chevron "A" style 6" Reflexite V98 striping full width on rear of body. Includes rear facing extrusions, panels and doors. Colors to be Red/Fluorescent Yellow Green.	1
WARRANTY / STANDARD & EXTENDED		
9100-0000	Standard 1 Year Warranty.	1
9100-0003	Lifetime Frame Warranty.	1
9100-0004	10 Year/100,000 Mile Structural Warranty for Alum Cab / Body - Statement of Warranty.	1
9100-0005	10 Year Stainless Steel Plumbing Warranty - Statement of Warranty.	1
9100-0019	10 Year Limited Paint and Perforation Warranty - For Sikkens Paint.	1
9100-0061	20 Year Frame Corrosion Wairranty. Includes Rails, Liners (if equipped), Crossmembers, Front Frame Extensions and Battery Tray Brackets.	1
SUPPORT, DELIVERY, INSPECTIONS AND MANUALS		
9300-0009	Manuals, Operator and Service CD-ROM.	1
9300-0016	Approval Drawings-Standard.	1
9300-0316	Fire Apparatus Safety Guide published by FAMA, latest edition.	1
Dealer Supplied Equipment		



18-15
CITY OF NEWTON FIRE DEPT.
NEWTON, MA.
074245

CUSTOM 42 PUMPER
E-ONE TYPHOON X MEDIUM CAB 4X2 CHASSIS

		HOSE LOAD:
1250 GPM HALE FLO PUMP		100' OF 1.75" DJ
750 GALLON WATER		300' OF 1.75" DJ
30 GALLON INTEGRAL CLASS "B" FOAM		800' OF 2.50" DJ
		1000' OF 4.00" DJH
COMP.	OPENING	INTERIOR DIMENSION
L1	42W 68H	42W 68H 76D LOWER
R1	42W 68H	42W 68H 76D LOWER
L2	54W 25H	56W 25H 72D UPPER
R2	54W 25H	56W 25H 72D LOWER
L3	42W 68H	42W 68H 76D UPPER
R3	42W 68H	42W 68H 76D LOWER
B1	36W 45H	38W 54H 26D

THIS DRAWING IS FOR REFERENCE PURPOSES. ALL DIMENSIONS ARE SUBJECT TO MINOR VARIATIONS DUE TO MANUFACTURING PROCESSES.
 This drawing is the property of E-One. It and its contents are to be returned to E-One, Inc. upon completion of the project. E-One, Inc. Its contents are confidential and must not be copied or submitted to third parties for use or examination.

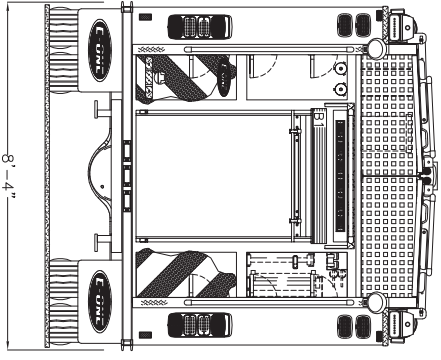
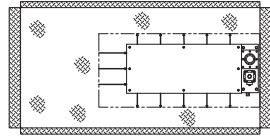

HOSE REEL HEIGHT:
 (FOR REFERENCE ONLY)
 TO TAIBOARD: 66"
 TO GROUND: 90"

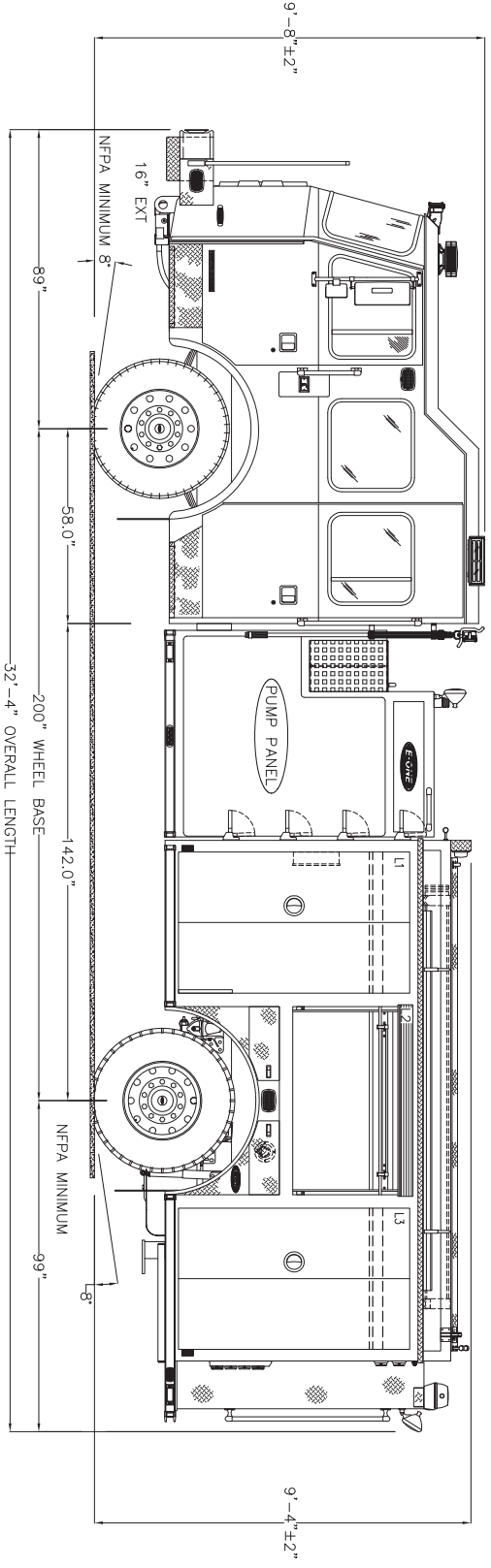

DATE	BY	SCALE	DESCRIPTION
11/15/17

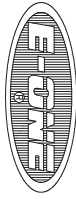

CITY OF NEWTON FIRE DEPT.
NEWTON, MA.

074245
CUSTOM 42 PUMPER
E-ONE TYPHOON X MEDIUM CAB 4X2 CHASSIS

THIS DRAWING IS FOR REFERENCE PURPOSES. ALL DIMENSIONS ARE SUBJECT TO MINOR VARIATIONS DUE TO MANUFACTURING PROCESSES.
THIS PART IS THE PROPERTY OF E-ONE, INC. and is loaned to you subject to return on demand, unless otherwise agreed to in writing by E-ONE, Inc. Its contents are confidential and must not be copied or submitted to third parties for use or examination.

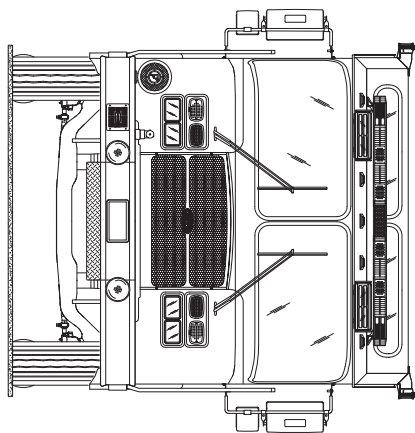
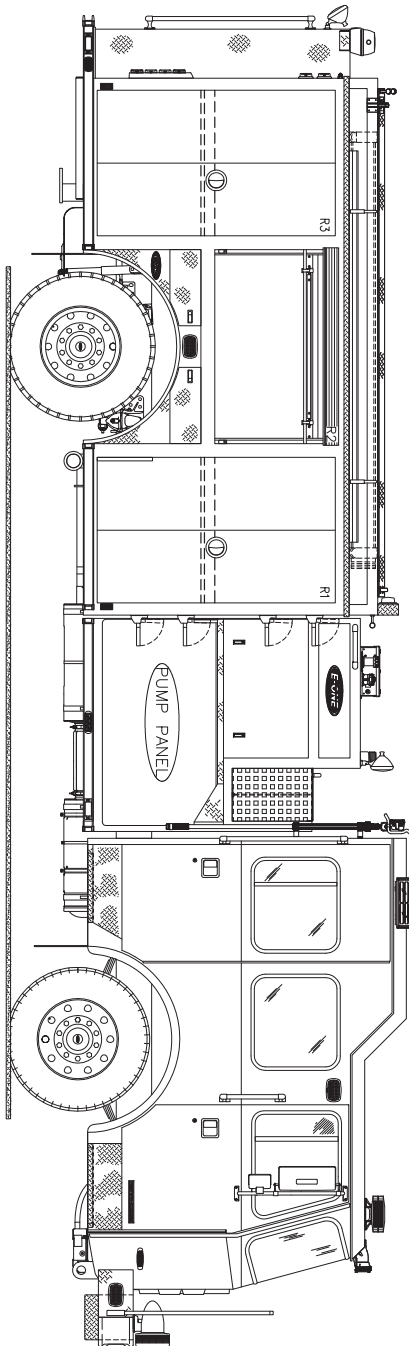

DATE	BY	APP'D	REV
07/15/15	MM	MM	1
REVISIONS			
NO.	DESCRIPTION	DATE	BY
1	ISSUE FOR QUOTE	07/15/15	MM



SETTI D. WARREN
MAYOR

City of Newton, Massachusetts
Office of the Mayor

#217-15

Telephone
(617) 796-1100

Facsimile
(617) 796-1113

TDD/TTY
(617) 796-1089

E-mail
swarren@newtonma.gov

August 31, 2015

Honorable Board of Aldermen
Newton City Hall
1000 Commonwealth Avenue
Newton, MA 02459

Ladies and Gentlemen:

I write to request that your Honorable Board docket for consideration a request to authorize the appropriation of \$504,750 and authorize a general obligation borrowing of an equal amount for the purchase of new Fire Department SCBA (Self Contained Breathing Apparatus) equipment listed in the FY2016-FY2020 Supplemental CIP. The current SCBA gear was last purchased in 2007. The new equipment is expected to last for 10 years.

This new equipment will have a GPS tracking device which will significantly enhance the department's ability to locate a firefighter in case of emergency.

Thank you for your consideration of this matter.

Very truly yours,

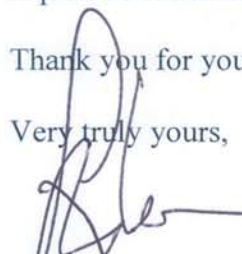
Setti D. Warren
Mayor

RECEIVED
Newton City Clerk
2015 AUG 31 PM 3:08
David A. Olson, CMC
Newton, MA 02459

1000 Commonwealth Avenue Newton, Massachusetts 02459

www.newtonma.gov



DEDICATED TO COMMUNITY EXCELLENCE



Bruce A. Proia
Chief

CITY OF NEWTON, MASSACHUSETTS
FIRE DEPARTMENT HEADQUARTERS

1164 Centre Street, Newton Center, MA 02459-1584
Chief: (617) 796-2210 Fire Prevention: (617) 796-2230
FAX: (617) 796-2211 EMERGENCY: 911



Setti D. Warren
Mayor

July 17, 2015

Maureen Lemieux
Chief Financial Officer
City Of Newton
1000 Commonwealth Ave
Newton, MA 02459

Maureen,

I respectfully request to docket funding of \$504,750.00 for the purchase of new Fire Department SCBA (Self Contained Breathing Apparatus) equipment. The current SCBA equipment was last purchased in 2007.

The purchase of this equipment is in the CIP for FY2016.

Thank you for your consideration to the request.

A handwritten signature in blue ink, appearing to read "B. Proia".

Bruce Proia
Chief of Department



Industrial Protection Services, LLC

P.O. Box 685 • 220 Ballardvale Street • Wilmington, Massachusetts 01887
 Tel: 978-657-4740 • Fax: 978-658-0257 • www.ipp-ips.com

QUOTE ORDER

SALES ORDER	
125439-00	
DATE	PAGE #
01/21/15	1

Bill To:

Newton Fire Dept
 Attn: Diane
 1164 Centre St
 Newton, MA 02459

Ship To:

Newton Fire Dept
 Chief Proia
 195 Craft St
 Newton, MA 02459

CUSTOMER P.O.		TERMS	SHIP VIA				SALES REP
Richie		Net 30	UPS Ground				KM
LN	ITEM # / DESCRIPTION	ORD	UM	B/O	SHIP	PRICE	AMOUNT
1	X3314021200302 AirPak, X3 PT EBSS	60	ea			5844.00	350640.00
2	804721-01 Cylinder, 4.5, 30 min carbon	20	ea			864.00	17280.00
3	804723-01 Cylinder, 4.5, 60 min carbon	2	ea			1240.00	2480.00
4	201215-05 Facepiece, SureSeal HT md, w/brkt	187	ea			304.00	56848.00
5	201275-01 Voice Amp, Epic 3	187	ea			396.00	74052.00
6	200266-04 Pak Tracker, HHR assembly	2	ea			1322.00	2644.00
7	200433-01 Truck Charger, Pak-track 12V DC	2	ea			403.00	806.00
						Total Invoice	504750.00
						Total	504750.00



SETTI D. WARREN
MAYOR

City of Newton, Massachusetts
Office of the Mayor

#216-15

Telephone
(617) 796-1100

Facsimile
(617) 796-1113

TDD/TTY
(617) 796-1089

E-mail
swarren@newtonma.gov

August 31, 2015

Honorable Board of Aldermen
Newton City Hall
1000 Commonwealth Avenue
Newton, MA 02459

Ladies and Gentlemen:

I write to request that your Honorable Board docket for consideration a request to authorize the appropriation of \$227,700 and authorize a general obligation borrowing of an equal amount for the purchase of a new Fire Department Bucket Truck listed in the FY2016-FY2020 Supplemental CIP. This will replace a 1996 truck that has over 165,000 miles on it. It is not cost effective to have the current vehicle in service as the safety components are failing and putting personnel at risk.

Thank you for your consideration of this matter.

Very truly yours,

Setti D. Warren
Mayor

RECEIVED
Newton City Clerk
2015 AUG 31 PM 3:08
David A. Olson, CMC
Newton, MA 02459

1000 Commonwealth Avenue Newton, Massachusetts 02459

www.newtonma.gov



DEDICATED TO COMMUNITY EXCELLENCE



Bruce A. Proia
Chief

CITY OF NEWTON, MASSACHUSETTS
FIRE DEPARTMENT HEADQUARTERS

1164 Centre Street, Newton Center, MA 02459-1584
Chief: (617) 796-2210 Fire Prevention: (617) 796-2230
FAX: (617) 796-2211 EMERGENCY: 911



Setti D. Warren
Mayor

August 25, 2015

Maureen Lemieux
Chief Financial Officer
City Of Newton
1000 Commonwealth Ave
Newton, MA 02459

Maureen,

I respectfully request to docket funding of \$227,700.00 for the purchase of a new Fire Department Bucket Truck. This will replace a 1996 truck that has over 165,000 miles on the truck. It is not cost effective to have this vehicle in service as the safety components are failing putting personnel at risk.

The purchase of this truck is in the CIP for FY2016.

Thank you for your consideration to the request.

A handwritten signature in blue ink, appearing to read "B. Proia".

Bruce Proia
Chief of Department

**INTERNATIONAL TRUCK
GREATER BOSTON POLICE COUNCIL
2014 COOPERATIVE PROCUREMENT CONTRACT
GBPC 2014-INTERNATIONAL**

101 2016 4300SBA cab & Chassis with Cummins ISB - 220hp Engine 25,500 lb. GVWR \$65,288.00

OPTIONAL EQUIPMENT:

ITEM #	DESCRIPTION	COST
106	ISB-260 HP Upgrade 4300	\$2,118.00
118	3000 RDS-P 5 or 6-Speed Allison Transmission	\$4,991.00
125	12,000 lb. Capacity Front Axle	\$1,224.00
128	21,000 lb. Capacity Rear Axle	\$1,124.00
137	120,000 psi 10.375" x 3.705" x 0.438"	\$1,026.00
141	Horizontal Switchback After Treatment with Vertical Tail Pipe	\$848.00
145	Optional Tire: 12R22.5 G16 PR	\$977.00
149	Air Conditioning	\$823.00
155	Dual Air Suspension Seats - Driver & Passenger	\$878.00
163	Dual ABS Air Brake System - Heated Air Dryer	\$1,754.00
173	Front Tow Hooks - Double	\$73.00
161	Engine Exhaust Brake	\$653.00
169	Body Circuit Switches "Twelve Pack"	\$1,150.00
170	Remote Start/Stop Diamond Logic Programming - Req. 6 or 12 Pack	\$607.00
159	2 Durastar Spare Tire and Wheel \$825.00 each	\$1,650.00
187	Bright Finish Aluminum Wheels - Front & Rear Axle	\$1,155.00
327	Dash Mounted Electric Brake Controller	\$300.00
328	Plate Mounted Pintle Hook with Trailer Plug	\$900.00
335	Aerial Lift 47' (working height) Device with Utility Service Body	\$78,600.00
633	Stainless Steel Upgrade	\$7,400.00
340	Upgrade to Insulated Boom	\$6,700.00
345	Hydraulic Tool Console at Bucket	\$590.00
346	Remote Engine Start/Stop - Requires 6/12 Pack with Remote S/S Programming	\$1,200.00
347	Emergency 12 Volt Hydraulic System	\$800.00
350	Single Stick Control System	\$1,100.00
352	Hydraulic Rotating Basket, 180°	\$2,100.00
349	Bucket Liner	\$650.00
370	Video System: Rear View	\$2,700.00
398	Automatic Transmission Mounted Central Hydraulic System	\$6,500.00
594	LED Strobe System: Two Flashers Mounted in Front Corners of Body and Two Rear Mounted Flashers with Brake and Turn Signals	\$2,800.00
600	Front maker light mounted LED Flashers	\$1,000.00
626	Service Body Crane - 4,000 lb.	\$10,500.00
669	DVD Rom Service Manual	\$325.00
	Custom Interior & Exterior Utility Service Body Modifications to include Collapsible "CR" reel with Remote Foot Pedal Control	\$2,671.00
TOTAL DELIVERED PRICE		\$ 213,175.00

SERVICING INTERNATIONAL DEALER

TAYLOR & LLOYD, INC.
8 Railroad Ave.
Bedford, MA 01730
781-275-9290

by Michael Fronk

7/15/2015

Date

MUNICIPALITY:

CITY OF NEWTON
FIRE DEPARTMENT
Centre St
Newton, MA 02459

These Contract prices are valid for orders placed before October 31, 2015.

Fire Station #3 and Headquarters Working Group

The Pre-Qualification and Selection Working Group Committee received three Construction Manager at Risk statements on April 9, 2015 in response to the city's request for qualifications issued on March 18th. The three submissions were from Colantonio, Inc., Commodore Builders and WT Rich. The committee met on May 15th to discuss the submissions and found that all three firms were qualified, and they were chosen for the Request for Proposal stage.

Proposals were received on July 1st and interviews were conducted on July 15th. Following the interviews and the review of the submissions and questions, the committee met to discuss the firms' presentations, technical proposals and fee proposals. The committee unanimously chose Commodore Builders to be the CM at risk for this project. Among the reasons were:

- a. The experience and skill set of the team proposed for the project;
- b. The experience with highly complex, phased construction and occupied renovation projects;
- c. Pre-construction processes for options analysis, budget controls, and constructability reviews;
- d. Strategies for coordinating the project efforts around fire department operations; and
- e. Shortest construction schedule which would limit duration of temporary fire operations.

The choice of Commodore Builders was approved by the Mayor on July 21st.

Dick Blazar, Jay Ciccone, Vicki Danberg