



Zoning & Planning Committee Agenda

City of Newton In City Council

Monday, April 25, 2016

7:45PM - Room 205

Items Scheduled for Discussion:

- #121-16** **Submission of the Economic Development Commission Annual Report**
ECONOMIC DEVELOPMENT COMMISSION submitting its 2015 annual report as required by City of Newton Ordinances, **Chapter 22, Section 95**. [03/25/16 @ 2:56 PM]
- #133-16** **Submission of the FY17 Annual Action Plan To HUD**
HIS HONOR THE MAYOR requesting City Council authorization, pursuant to the 2013 Revised Citizen Participation Plan, to submit to the US Department of Housing and Urban Development (HUD) the FY2017 Annual Action Plan for the City of Newton Community Development Block Grant (CDBG) and Emergency Solution Grant (ESG) funds and the WestMetro HOME Consortium. These Plans must be submitted to HUD by May 15, 2016. [04/14/16 @ 2:14 pm]
- #278-14(2)** **Zoning amendment to clarify definition of two-family detached dwelling**
COUNCILOR HESS-MAHAN requesting an amendment to clarify the intent of **Chapter 30 Section 1.5.1.B** definition of Two-Family Detached Dwelling. [03/31/16 @ 11:00 AM]
- #22-16** **Resolution requesting appropriate training of Fair Housing laws**
COUNCILOR HESS-MAHAN proposing a RESOLUTION to the Mayor and City Council requesting that all members of municipal public bodies that have decision-making authority or an advisory role with respect to land use, zoning or housing issues be required to receive appropriate orientation or training concerning applicable rights and obligations under Fair Housing laws and regulations. [02/07/16 @ 3:01 PM]
- #55-16** **Ordinance to require fair housing statement and HUD logo on certain meeting notices**
COUNCILOR HESS-MAHAN requesting an ordinance to require that all notices of public hearings and/or meetings concerning permitting and/or funding of any residential development contain a brief statement concerning the City's policy regarding fair housing practices pertaining thereto and HUD's Equal Housing Opportunity logo. [02/03/16 @ 1:51 PM]

The location of this meeting is handicap accessible and reasonable accommodations will be provided to persons requiring assistance. If you need a special accommodation, *please contact Jini Fairley, at least two days in advance of the meeting: jfairley@newtonma.gov, or 617-796-1253. For Telecommunications Relay Service dial 711.*

Items Not Scheduled for Discussion at this meeting:

- #222-13(2) Zoning amendment to regulate front-facing garages in residential zones**
THE ZONING AND PLANNING COMMITTEE proposing to amend **Chapter 30**, City of Newton Zoning Ordinances, to regulate the dimensions and setbacks of front facing garages in residential zoning districts. [08/03/15 @ 10:15 AM]
- #103-16 Petition to rezone lots on Glen Avenue from MR1 to SR2**
COUNCILORS DANBERG, BLAZAR, SCHWARTZ , SANGIOLO AND YATES petitioning to rezone land known as Section 61, Block 39, Lots 01, 02, 03 and 04 located at 41, 45, 47 and 51 Glen Avenue from MULTI RESIDENCE 1 to SINGLE RESIDENCE 2 [03/17/16 @ 1:50 PM]
- #122-16 Discussion with ISD re procedures to protect abutters during demo projects**
COUNCILORS NORTON AND AUCHINCLOSS requesting discussion with the Inspectional Services Department relative to the City's procedures to protect abutters during demolition projects and whether Newton is requiring developers to take sufficient steps. [03/25/16 @ 12:07 PM]
- #110-15 Discussion of the Smart Growth Zoning Overlay District Act in Newton**
HIS HONOR THE MAYOR requesting discussion of The Smart Growth Zoning Overlay District Act M.G.L. Chapter 40R and its potential application in Newton. [04/24/15 @ 2:38 PM]
- #54-16 Zoning ordinance amendment relative to Health Club use**
ACTING DIRECTOR OF PLANNING proposing amendments to the Newton Zoning Ordinance to allow the "Health Club" use in Business 1, Business 2 and Business 4 districts; and to clarify the definition of "Personal Service" as it relates to health and fitness uses. [02/09/16 @ 4:24 PM]
ITEM SPLIT INTO PART A AND PART B:
PART A – To allow Health Club use in BU1, BU2 and BU4;
PART B – To clarify the definition of Personal Services as it relates to health and fitness issues.
Approved Part A 6-0
Held Part B 6-0
- #109-15 Zoning amendment for inclusionary housing provisions from 15% to 20%**
HIS HONOR THE MAYOR requesting consideration of changes to the inclusionary housing provisions of the Zoning Ordinance to increase the required percentage of affordable units to 20% with the additional 5% set aside for middle income households. [04/24/15 @ 2:38 PM]

- #108-15** **Zoning amendment for accessory apartments supportive of seniors**
HIS HONOR THE MAYOR requesting consideration of changes to the Zoning Ordinance that would facilitate the creation of accessory apartment units, supportive of Newton's seniors. [04/24/15 @ 2:38 PM]
- #164-09(2)** **Request for amendments to dimensional requirements for accessory apartments**
ALD. HESS-MAHAN requesting that the Planning Department study the dimensional requirements for lot and building size for accessory apartments and make recommendations for possible amendments to those dimensional requirements to the board of Aldermen that are consistent with the Newton Comprehensive Plan.
- #61-10** **Discussion relative to bringing existing accessory apartment into compliance**
ALD. CICCONE, SWISTON, LINSKY, CROSSLEY AND HESS-MAHAN requesting a discussion relative to various solutions for bringing existing accessory and other apartments that may not meet the legal provisions and requirements of **Chapter 30** into compliance.
- #64-13** **Permitting for conversion of historic barns/carriage houses to accessory apts**
HISTORICAL COMMISSION requesting the creation of an administrative permitting process for converting historic barns and carriage houses into accessory apartments to assist in their preservation.
- #80-13** **Updates on the zoning reform project**
THE PLANNING DEPARTMENT requesting update discussions of the zoning reform project. [02/25/13 @ 12:31 PM]
- #323-14** **Zoning amendment to require front-facing front doors in residential zones**
ALD. YATES, NORTON, COTE AND SANGIOLO proposing to amend **Chapter 30** to require that the front doors of single-family homes, two-family homes and other residential structures face the street on which their lots are located. [08/25/14 @ 11:42 AM]
- #265-14** **Request to increase several time periods for demolition delays**
ALD. BLAZAR, YATES AND DANBERG requesting:
1. to amend Section 22-50 to increase the time period for determinations of historical significance to 30 days, and to increase the time period for hearings, rulings and written notice on appeals from historical significance determinations to 60 days;
 2. to amend Section 22-50 to increase the time period to hold a public hearing as to whether or not a historically significant building or structure is preferably preserved to 60 days;

3. to amend Section 22-50 to increase the demolition delay period for buildings and structures on or eligible for listing in the National Register of Historic Places to 30 months;
1. and to amend Section 22-50 to increase the demolition delay period for all other preferably preserved buildings or structures to 24 months. [7/07/14 @ 12:35 PM]

#447-14 **Proposing an ordinance to require building plans with demolition applications**
ALD. SANGIOLO proposing an ordinance requiring the submission of building plans with applications for full or partial demolitions. [11/13/14 @ 2:03 PM]

#169-15 **Zoning amendment to require new lot standards after demolition**
ALD. SANGIOLO requesting a zoning amendment which would require any residential structures in Single Residence or Multi Residence zoning districts built after the demolition of an existing structure conform to new lot standards. [07/02/15 @ 3:20 PM]

#264-13 **Zoning amendment to develop residential districts for small lots**
ALD. YATES requesting that the Zoning Reform Group or its successor consider amending City of Newton Zoning Ordinances **Chapter 30** to develop additional residential districts reflecting the small lots in older sections of the City and map changes to bring the zones of more residential sections of the City into conformity with the existing land uses. [08/15/13 @ 12:28 PM]

#34-16 **Zoning amendment for large house review process**
COUNCILORS SANGIOLO, KALIS AND DANBERG proposing an amendment to Chapter 30 for a large house review ordinance requiring design review and approval of by-right single and multi-residence residential structures exceeding certain dimensional limits. [01/19/16 @ 2:35 PM]

#142-09(7) **Resolution to reconvene Floor Area Ratio working group**
ALD. HESS-MAHAN AND JOHNSON proposing a Resolution to request that the Director of Planning and Development and the Commissioner of Inspectional Services reconvene a Floor Area Ratio working group to review and analyze the definition of "*Floor area, gross*" for residential structures as it is used in the definition and calculation of "*Floor area ratio*" in **Section 30-1** with respect to actual usage, and, if necessary, make recommendations for amendments thereto and in the dimensional regulations contained in **Section 30-15(u)** and *Table A* of **Section 30-15(u)**, the purpose of which is to regulate the size, density and intensity of use in the construction or renovation of, or additions to a residential structure, to more accurately reflect and be compatible with neighborhood character, and to ensure that a proposed residential structure is consistent with and not in derogation of the

size, scale and design of other existing structures in the neighborhood, and is not inconsistent with the City's Comprehensive Plan.

- #238-14 Request for development of Housing Production Plan**
ALD. SANGIOLO requesting the Executive Department and Planning Department work with the Board of Aldermen to develop a Housing Production Plan in accordance with 760 CMR 56.03(4) and guidelines adopted by the Department of Housing and Community Development as soon as possible. [06/09/14 @ 11:55 AM]
- #445-14 Update from Newton Fair Housing Committee on housing opportunities**
ALD. SANGIOLO requesting an update with members of the Newton Fair Housing Committee on the status of housing opportunities in the City of Newton. [11/13/14 @ 2:03 PM]
- #170-15 Discussion of HUD settlement relative to creating 9-12 affordable units**
ALD. HESS-MAHAN, JOHNSON, CROSSLEY AND ALBRIGHT requesting a discussion relative to the HUD Settlement with Supporters of Engine 6, the Fair Housing Center of Greater Boston and the Disability Law Center in conjunction with the Law and Planning Departments, to explain the settlement and possible implications for the Zoning Board of Appeals and the Board of Aldermen in terms of the City's obligation to identify sites and facilitate the creation of, and issue permits for, affordable housing for 9-12 chronically homeless persons in Newton. [07/06/15 @ 4:18 PM]
- #22-15 Zoning amendment to allow rental voucher program re: inclusionary zoning**
ALD. YATES requesting that utilization of the Massachusetts Rental Voucher Program be added as an allowable means of complying with the inclusionary zoning provision in Phase II of Zoning Reform. [01/05/15 @ 9:53 PM]

Referred to Zoning & Planning, Land Use and Finance Committees

- Qualification of affordable units on Comm Ave, Pearl and Eddy Streets**
#104-15 ALD. JOHNSON, LAREDO, AND GENTILE requesting a report from the Planning Department with the following information: How many of the affordable units developed at Commonwealth Avenue, Pearl Street, and Eddy Street qualify to be included on the State's Subsidized Housing Inventory List. If a property is not currently on the list, what can be done to make it eligible. [04/09/15 @ 12:00 PM]
- #107-15 Discussion of middle income housing supportive of City employees**
HIS HONOR THE MAYOR requesting discussion of approaches to create middle income housing as a means of allowing City of Newton employees the opportunity to live in the community in which they work. [04/24/15 @ 2:38 PM]
- #81-13 Request for naturally affordable compact housing opportunities**

DIRECTOR OF PLANNING & DEVELOPMENT on behalf of the Newton Housing Partnership requesting consideration of naturally affordable compact housing opportunities in MR1 zones. [02/22/13 @ 1:13 PM]

- #86-15** **Discussion and review of CDBG fund expenditures and citywide goals**
ALD. CROSSLEY, ALBRIGHT, HESS-MAHAN, & JOHNSON requesting a review and discussion of Community Development Block Grant expenditures and past years' accounting to assess progress in meeting citywide program goals as adopted in the consolidated plan, including creating and sustaining affordable housing, as well as facilities improvements in approved neighborhood districts. [03/30/15 @ 6:02 PM]
- #427-13** **Discussion of CDBG, HOME and ESG funds and fair housing**
ALD. HESS-MAHAN requesting discussion and periodic updates of steps the City of Newton is taking to ensure that its implementation of the Consolidated Plan, Annual Action Plan and Citizen Participation Plan and use of CDBG, HOME and ESG funds comply with federal and state fair housing and anti-discrimination laws and regulations, and its duty to affirmatively further fair housing. [12/06/13 @ 9:51 AM]
- #308-12** **Discussion of policies relative to CDBG fund expenditures**
ALD. HESS-MAHAN & ALBRIGHT requesting a discussion with the Mayor's office and the Planning & Development Department of policies, procedures, and criteria relating to determinations concerning expenditures of Community Development Block Grant (CDBG) funds. [10/09/12 @ 3:59 PM]
- #315-14** **Referred to Zoning & Planning and Finance Committees**
Ordinance amendment for procurement requirements for non-profits
ALD. HESS-MAHAN, ALBRIGHT, CROSSLEY AND DANBERG proposing an amendment to Chapter 2 of the City of Newton Ordinances setting forth requirements for procurement of materials and services by non-governmental recipients of federal, state or local funds administered by the City, such as CDBG and CPA funds. In order to encourage non-profit and other private organizations to participate in affordable housing, cultural and other public-private collaborations, such procurement requirements should accommodate the needs of non-governmental recipients for flexibility given the multiple public and private sources of funds necessary for any project by not placing undue or unreasonable burdens on them.
[08/04/14 @ 5:08 PM] Finance voted NAN
- #446-14** **Discussion with Commission on Disability regarding the City's ADA compliance**
ALD. SANGIOLLO requesting a discussion with the Commission on Disability regarding the status of City compliance with ADA regulations. [11/13/14 @ 2:03 PM]
- #140-14** **Zoning amendment for lodging house ordinance**

ALD. CROSSLEY AND HESS-MAHAN requesting to amend **Chapter 30**, City of Newton Zoning Ordinances, to include a "lodging house" ordinance to promulgate rules requiring annual fire, safety and health inspections and licensing of buildings providing single room occupancy and/or congregate living arrangements.
[04/04/14 @ 6:29 PM]

#429-13 Zoning amendment for Congregate Living Facility parking requirements

ALD. HESS-MAHAN requesting repeal and/or amendment of Zoning Ordinances **Section 30-1**, Definitions, 30-8(b)(2), Special Permits in Single Family Residential Districts, and 30-10(d)(4), Number of Parking Stalls, concerning "Congregate Living Facility", as required by federal and state anti-discrimination and fair housing laws and regulations. [12/06/13 @ 9:51 AM]

#35-16 Creation of policy to require posting of materials of boards/commissions

COUNCILOR SANGIOLO requesting a discussion with the Planning Department relative to creating a policy to require audio recordings of all meetings of boards and commissions and posting of same to the City's website, as well as posting of all documentation that is reviewed by boards and commissions and/or by their designated City staff member. [01/19/16 @ 2:35 PM]

#129-13 Zoning amendment for special permits for attached dwellings

ALD. HESS-MAHAN proposing to amend and/or clarify definition and provisions for granting a special permit for "attached dwellings" in the City of Newton Zoning Ordinances, **Chapter 30-1, 30-8(b)(13) and 30-9(b)(5)**. [05/25/13 @ 5:14 PM]

#65-13 Zoning amendment to require special permit for major topographic changes

ALD. YATES, FISCHMAN, KALIS requesting that **Chapter 30** be amended to require a special permit for major topographic changes.]

#139-14 Zoning amendment to clarify rules for retaining walls

ALD. ALBRIGHT requesting to amend **Chapter 30**, City of Newton Zoning Ordinances, to clarify rules relative to retaining walls.

#391-09 Zoning amendment to allow payments-in-lieu of parking spaces: special permits

ALD. DANBERG, MANSFIELD, VANCE AND HESS-MAHAN requesting an amendment to **§30-19** to allow payments-in-lieu of providing required off-street parking spaces when parking spaces are waived as part of a special permit application.
[09/09/09 @ 3:53 PM]

#152-10 Zoning amendment to clarify parking requirements for colleges and universities

ALD. BAKER, FULLER, SCHNIPPER, SHAPIRO, FISCHMAN, YATES AND DANBERG

recommending discussion of possible amendments to **Section 30-19** of the City of Newton Ordinances to clarify parking requirements applicable to colleges and universities.

#153-11

Zoning amendment for Retail Overlay Districts around village centers

ALD. DANBERG, ALBRIGHT, HESS-MAHAN, JOHNSON requesting that **Chapter 30** be amended by adding a new **Sec. 30-14** creating certain Retail Overlay Districts around selected village centers in order to encourage vibrant pedestrian-oriented streetscapes which would allow certain uses at street level, including but not limited to financial institutions, professional offices, and salons, by special permit only and require minimum transparency standards for street-level windows for all commercial uses within the proposed overlay districts.

#168-15

Discussion of Metropolitan Area Planning Council's Wells Avenue Market Study

THE NEWTON-NEEDHAM CHAMBER OF COMMERCE requesting a discussion of the Metropolitan Area Planning Council's 2015 Wells Avenue Market Study.
[07/06/15 @ 5:34 PM]

#95-15

Discussion to consider mix of uses at Wells Avenue Office Park

ALD. CROSSLEY, JOHNSON, LEARY, HESS-MAHAN, DANBERG, ALBRIGHT AND BLAZAR requesting a discussion with the Planning Department to consider the mix of uses in the Wells Avenue Office Park, with and without a second egress to the site, pursuant to the recent MAPC study recommending a strategic introduction of retail and restaurant uses to attract and sustain healthy commercial uses, and some number of residential units sufficient to support an economically viable and vibrant mixed use environment. [04/13/15 @ 2:46 PM]

Referred to Finance and Appropriate Committees

#288-15

Submittal by the Mayor of the FY17 Capital Improvement Plan

HIS HONOR THE MAYOR submitting the FY 2017-FY 2021 Capital Improvement Plan pursuant to section 5-3 of the Newton City Charter. [10/01/15 @ 1:53 PM]

Referred to Zoning & Planning, Land Use and Finance Committees

#273-12

Request to restructure and increase of fees for various permits

ALD. CROSSLEY & HESS-MAHAN requesting a restructuring and increase in fees for permits charged by the Inspectional Services Department and fees charged by the Planning Department and City Clerk to assure that fees are both sufficient to fund related services provided and simple to administer. [09/10/12 @ 1:17 PM]
Finance and Land Use voted NAN

Referred to Finance and Appropriate Committees

#257-12

Review of fees in Chapter 17 and Chapter 20

RECODIFICATION COMMITTEE recommending (1) review of the Fees, Civil Fines/Non-Criminal Disposition contained in Chapter 17 LICENSING AND PERMITS GENERALLY and Chapter 20 CIVIL FINES/NON-CRIMINAL DISPOSITION CIVIL FINES to ensure they are in accordance with what is being charged and (2) review of the acceptance of G.L. c. 40 §22F, accepted on July 9, 2001, which allows certain municipal boards and officers to fix reasonable fees for the issuance of certain licenses, permits, or certificates. Finance voted NAN

#195-15(3) Request to acquire land at 300 Hammond Pond Parkway
ALD. ALBRIGHT, BAKER, BLAZAR, BROUSAL-GLASER, CICCONE, COTE, CROSSLEY, DANBERG, FULLER, GENTILE, HESS-MAHAN, JOHNSON, KALIS, LAPPIN, LEARY, LAREDO, LENNON, LIPOF, NORTON, RICE, SANGIOLO, SCHWARTZ, AND YATES requesting that, in order to preserve the conservation and recreation values of the land, and to protect existing adjacent public open spaces, the Board of Aldermen vote to acquire for the City of Newton either the undeveloped portion of the land at 300 Hammond Pond Parkway or a conservation restriction on such land.
[10/23/15 @ 2:55 PM]

#404-13 Request for rezoning in Newton Centre
NATASHA STALLER et al. requesting a revision to the zoning District boundary Lines so as to transfer from Multi-Residence 1 District to a Single Residence 3 District the following properties:
Assessors' parcels SBL nos. 61-037-0004 through 61-037-0013; 61-042-0007 through 61-042-0023; 65-019-0001; 65-019-0007 through 65-019-0012; 65-019-0014 through 65-019-0022; 65-019-0009A; 65-019-0017B and 65-019-0022A. Also requesting transfer from a Single Residence 2 District to a Single Residence 3 District SBL no. 65-019-0015A.

Respectfully Submitted,

Ted Hess-Mahan, Chair



Setti D. Warren
Mayor

James Freas
Acting Director
Planning & Development

Nancy Hyde
Economic Development
Director

Commissioners

- Stephen Feller, Chair
- Janice Caillet, Secretary
- Howard Barnstone
- Daphne Collins
- Barbara Couturier
- Robert Finkel
- Jane Ives
- Jack Leader
- Peter Kai Jung Lew
- John Pears
- Joyce Plotkin
- Philip Plottel

1000 Commonwealth Ave.
Newton, MA 02459
T 617/796-1120
F 617/796-1142

CITY OF NEWTON, MASSACHUSETTS

Economic Development Commission

2015 ANNUAL REPORT

Prepared for: Mayor Setti D. Warren and Newton City Council

Prepared by: Newton Economic Development Commission

Submitted: March 2016

RECEIVED
 Newton City Clerk
 2016 MAR 25 PM 2:56
 David A. Olson, Clerk
 Newton, MA 02459

Background

The Economic Development Commission (EDC) was established under General Laws Chapter 40, Section 8A to promote and develop business and industry within the City of Newton. The Commission is charged with strengthening the local economy leading to new job opportunities for residents and expansion of the City's tax base. City Ordinance Article V, Section 22-95 lays out the governing provisions as summarized below:

1. The Commission shall consist of 15 members appointed by the Mayor.
2. The Commission has the power and duty to:
 - study, investigate, and appraise economic conditions and trends;
 - promote, assist, and encourage the preservation, development and location of new and existing Newton industry, business and commerce;
 - investigate and assist in the establishment of commercial projects and identify appropriate commercial areas and zones for such establishment;
 - prepare and distribute informational publications;
 - cooperate with civic agencies/commissions/associations, state/federal agencies, municipal departments and officials, and business associations and organizations; and
 - advise and make recommendations to appropriate officials, agencies, boards, department, and commissions of the City.

This report is prepared and submitted to the Board of Aldermen in compliance with City Ordinance Article V, Section 22-95 (g) (10).

2015 in Review

During 2015, the EDC has been involved in the following:

- **N² Corridor** – The EDC continued to support the N² Corridor Initiative. C. Steele assisted in the preparation of a grant application to the Economic Development Administration for a Local Technical Assistance grant of \$50,000 which was awarded in August. This grant, in combination with matched funds from area property owners and Newton and Needham will help the Newton and Needham communities and Chamber of Commerce develop the planning and technical expertise to support comprehensive, entrepreneurial, and innovation-based economic development efforts. This is designed to result in increased private investment and higher-skill, higher-wage jobs, as well as enhanced competitiveness.
- **Austin Street** – Austin Street Partners presented their proposal for the development of 28 Austin Street to the EDC in both June and September after filing their Special Permit

application with the Board of Aldermen in May. The EDC issued a letter of support which was submitted to the BOA in October. The special permit was approved by the Board of Aldermen on December 8, 2015.

- **Siamab** - Special permit application for rDNA research use in new location at Wells Avenue. (Note: The Director of Health and Human Services approved the rDNA permit on September 29, 2015.) The EDC provided a letter of support for the special permit application. The special permit was approved by the Board of Aldermen on October 19, 2016.
- **Economic Development Strategy** - The Economic Development Commission is focusing on fundamental building blocks of Newton's economic development (village centers and commercial corridors) as well as marketing and promotion, small business development and regulatory measures, and an overarching interest in ensuring that the right strategies are in place to encourage development. Specifically, the four focus areas were determined to be (1) marketing and communication, (2) villages, (3) corridors, and (4) small business development.

Invited Guests – The EDC will, on occasion, invite guest speakers to its meetings. The following guests attended EDC meetings during 2015:

SCORE Presentation - Elizabeth Brown & Dan Perkins

The EDC engaged in a discussion with Dan Perkins and Elizabeth Brown, both consultants with SCORE (Service Core of Retired Executives). Dan is a past chair of the Boston Chapter. The Boston Chapter of SCORE offers individuals free counseling, low-cost workshops, and free team visits to business locations to conduct business reviews. SCORE teams provide counseling designed to assist a business to:

- Increase the value of a business by growing sales, earnings, and cash flow
- Identify and solve operating problems
- Recognize and capitalize on new business opportunities
- Make needed changes and add new systems
- Develop business plans
- Find sources and qualify for needed financing

Dan and Elizabeth are hoping to develop their outreach in Newton. They have 10 new counselors, 8 counselors undergoing training and another 8 counselors on a waiting list. This gives them more capacity to grow the number of people who they can provide services to. The consultants are all volunteers and provide their counseling services at no charge. They cover their overhead costs with a

small stipend from the federal government. SCORE successfully began offering consulting hours one day per week at the Newton Free Library pursuant to their presentation to the EDC.

Austin Street

Alan Schlesinger, attorney for Austin Street Partners, presented on two occasions to the Commission covering the history of events leading up to the submission of the special permit application in May, the project proposal submitted and highlights of changes from the original response to the City's RFP, plans for parking, the building, and public space.

- 8 Must haves –
 - #1 ... More housing for all of us including more affordable apartments
 - #2 ... A design that fits in Newtonville
 - #3 ... It's got to be green – transit oriented sustainable construction and operation
 - #4 ... A more beautiful Newtonville – new sidewalks, streets, lights & landscaping
 - #5 ... A more vibrant Newtonville – new residents, new shops
 - #6 ... An improved Austin Street parking lot – 127 parking spaces
 - #7 ... Don't kill the village trying to save it – interim parking for shoppers
 - #8 ... Lease the land, don't sell it – our children's children can decide again
- The developer appeared before the Urban Design Commission; the building design has been adjusted to reflect UDC feedback
- The reduction in the retail space from 9,000SF to 5,000 SF was discussed. The reduction allows for increase to both public parking and below grade parking.
- Design of affordable and market rate units the same

Noted financial benefits to the City - \$1.05 million up front lease payment, new paved parking lot, I&I payment of \$750k, public space, taxes, and revenue stream from parking.

BikeBus (Eric and Seema Brodie)

Eric and Seema Brodie provided an overview of their new start-up business – BikeBus. This is an indoor cycling business run out of a bus. The cycling can be done on a commute from West Newton to Boston, as a social event or for corporate team building.

Business Excellence Award Recipients

The EDC continued its successful Business Excellence Awards program with the 4th annual ceremony taking place on October 26th. The winners who received awards at the Awards Ceremony are as follows:

Award Categories	Award Recipient
Charles River Mill District Award	Fairlane Properties
Citizen Champion Award	Steven Feinstein
Community Business Award	Newton-Wellesley Hospital
Destination Business Award	Jewish Community Center
Innovation Business Award	The Bullfinch Companies
N ² Corridor Award	SocialMadeSimple
Village Business Award - Newton Centre	Whole Foods
Village Business Award - Newton Centre	Johnny's Luncheonette
Village Business Award - Newton Highlands	O'Hara's Food & Spirits
Village Business Award - Newtonville	Cabots Ice Cream and Restaurant
Village Business Award - Nonantum	West Street Tavern
Village Business Award - West Newton	Harris Cyclery
Certificate of Recognition	Newton Community Farm

NOTE: The Economic Development Commission will host the 5th Annual Business Awards event in January 2017.

EDC Membership 2015

Howard Barnstone
Janice Caillet
Daphne Collins
Barbara Couturier
Stephen Feller
Robert Finkel
Jane Ives
Jack Leader
Peter Kai Jung Lew
John R. A. Pears
Joyce Plotkin
Philip Plottel
Darryl Settles – Resigned February 2015
Christopher Steele – Resigned November 2015
David Swanson – Resigned August 2015

Officers - The EDC held annual elections of officers in February 2015 - Stephen Feller, Chair; Christopher Steele, Vice Chair; and Janice Caillet, Secretary.

Staffing - Nancy Hyde continues to serve as Economic Development Director.

Attachments

- A. Letter to FFYs 2015-2018 Transportation Improvement Program Amendment 3
In Support of Placing Newton/Needham's Needham Street/Highland Avenue FFY 2018 TIP
- B. Letter of Support – Siamab
- C. Letter of Support – 28 Austin Street



July 14, 2015

Mr. Sean Pflazer
Transportation Improvement Program Manager
State Transportation Building
Ten Park Plaza Suite 2150
Boston MA 02116-3968

Re: FFYs 2015-2018 Transportation Improvement Program Amendment 3
In Support of Placing Newton/Needham's Needham Street/Highland Avenue
FFY 2018 TIP

Setti D. Warren
Mayor

James Freas
Interim Director
Planning & Development

Nancy Hyde
Economic Development
Director

Commissioners

Stephen Feller, Chair
Christopher Steele, Vice
Chair
Janice Caillet, Secretary

Howard Barnstone
Daphne Collins
Barbara Couturtier
Robert Finkel
Jane Ives
Jack Leader
Peter Kai Jung Lew
John Pears
Joyce Plotkin
Philip Plottel
David Swanson

1000 Commonwealth Ave.
Newton, MA 02459
T 617/796-1120
F 617/796-1142

[http://www.newtonma.gov/
gov/planning/lrplan/econdev](http://www.newtonma.gov/gov/planning/lrplan/econdev)

Dear Mr. Pflazer:

On behalf of the Newton Economic Development Commission, I wish to express strong support for the MPO's vote to place the Needham Street/Highland Avenue Corridor project on the FFY 2018 TIP.

The Needham Street/Highland Avenue corridor project has been long in the making. We are pleased to be working with our neighboring Town of Needham and have already been awarded a MassWorks grant to fund a portion of the overall corridor project. The grant will fund the reconstruction of Highland Avenue from First Avenue to the bridge approach in Needham and the intersection of Oak and Christina on Needham Street in Newton. Further, MassDOT has agreed to fund the design and construction of the First Avenue intersection in Needham.

We wish to emphasize the importance of this corridor project for economic development in our region. We have a strong economic development initiative underway for the N2 Corridor, which is a destination for technology companies, start-ups and other innovators. The improvements to this significant roadway, which links our two communities, will provide long overdue, infrastructure improvements that allow for multi-model transportation.

We applaud all efforts to date to move the project forward, inclusive of placing it on the FFY 2018 TIP.

Sincerely,

Stephen Feller, Chairman
Newton Economic Development Commission



Setti D. Warren
Mayor

James Freas
Interim Director
Planning & Development

Nancy Hyde
Economic Development
Director

Commissioners

Stephen Feller, Chair
Christopher Steele, Vice
Chair
Janice Caillet, Secretary

Howard Barnstone
Daphne Collins
Barbara Couturier
Robert Finkel
Jane Ives
Jack Leader
Peter Kai Jung Lew
John Pears
Joyce Plotkin
Philip Plottel

1000 Commonwealth Ave.
Newton, MA 02459
T 617/796-1120
F 617/796-1142

<http://www.newtonma.gov/gov/planning/lrplan/econdev/commission.asp>

October 2, 2015

The Honorable Marc Laredo, Chairman
Aldermen of the Land Use Committee
Board of Aldermen
City of Newton
1000 Commonwealth Avenue
Newton Centre, MA 02459

RE: Special Permit #119-15
Austin Street, 28 Austin Street

Dear Alderman Laredo and Aldermen of the Land Use Committee:

The Economic Development Commission is pleased to report that at its September 8, 2015 meeting, we voted in favor of Austin Street Partner's plan to develop 28 Austin Street.

The EDC's support for the development of 28 Austin Street is based on:

- Consistency with the Economic Development Goals and Strategies identified in Newton's Comprehensive Plan (NCP), specifically -
Section IV.1. Village Center Development
 - *Encourage mixed use in the village centers by promoting housing above retail. Increasing density allowing mixed-use development in the village centers would increase the population within walking distance and as a result would likely expand the available range of goods and services offered there. It would also increase the stock of affordable housing located close to employment centers and public transportation.*
- Adoption of the Board of Alderman's creation of a Mixed Use 4 (MU4) Zone
- Selection of Austin Street Partners in May 2014 based on the criteria established for the 2013 RFP
- Responsiveness to community feedback including
 - Reduction in number of total apartments from 80 to 68
 - Increased public parking on the ground level from 85 to 127 public parking spaces
 - Increasing below grade parking for the apartments from 1.0 to 1.25 and the addition of 5 employee parking spacing for retail tenants for a total of 90 below grade spaces
 - Retention of 25% affordable housing units while reducing total apartment units to 68; and
 - entering into a lease arrangement for the land, and

- Redevelopment of a single purpose parking lot into a multi-use building while retaining 127 public parking spaces.

Thank you for your time and consideration.

Sincerely,

Stephen Feller

Stephen Feller, Chairman
Newton Economic Development Commission

cc: Mayor Setti D. Warren
Board of Aldermen Chair, Scott Lennon
Acting Planning and Development Director, James Freas



October 15, 2015

Board of Aldermen
City of Newton
1000 Commonwealth Avenue
Newton Centre, MA 02459

Setti D. Warren
Mayor

RE: Special Permit - Siamab Therapeutics

James Freas
Interim Director
Planning & Development

Dear Aldermen,

Nancy Hyde
Economic Development
Director

On Behalf of the Newton Economic Development Commission, I wish to express strong support for the special permit application from Siamab Therapeutics for its laboratory facility located at 90 Bridge Street, Suite 100, Newton, MA.

Commissioners

We understand that Newton's Bio Safety Committee met with company representatives from Siamab on September 29, 2015 to review required documents and protocols. The Bio Safety Committee has subsequently signaled its unanimous support to recommend the Commissioner of Health and Human Services approve the rDNA permit.

Stephen Feller, Chair
Christopher Steele, Vice
Chair
Janice Caillet, Secretary

Siamab will be located in the Charles River Mill District, an established innovative community that is already home to many innovative companies in historic mill buildings located in Newton and the neighboring communities of Watertown and Waltham.

Howard Barnstone
Daphne Collins
Barbara Couturtier
Robert Finkel
Jane Ives
Jack Leader
Peter Kai Jung Lew
John Pears
Joyce Plotkin
Philip Plottel

In closing, the Economic Development Commission strongly supports Siamab's application and urges you to award the special permit.

Sincerely,

Steve Feller

Stephen Feller, Chairman
Newton Economic Development Commission

1000 Commonwealth Ave.
Newton, MA 02459
T 617/796-1120
F 617/796-1142

<http://www.newtonma.gov/gov/planning/lrplan/econdev/commission.asp>

FY17 ANNUAL ACTION PLAN

DRAFT – April 1, 2016

FOR THE
CITY OF NEWTON
HOUSING AND COMMUNITY DEVELOPMENT PROGRAM
AND THE
WESTMETRO HOME CONSORTIUM

JULY 1, 2016 – JUNE 30, 2017

*For submission to the Department of Housing and Urban Development
May 15, 2016*

EXECUTIVE SUMMARY

AP-05 Executive Summary - 24 CFR 91.200(c), 91.220(b)

1. Introduction and summary of objectives and outcomes identified in this plan:

TBD

2. Evaluation of past performance:

TBD

3. Summary of citizen participation process and consultation process:

Summary of public comments received

To be completed following the conclusion of the 30-day public comment period on May 3, 2016.

Summary of comments or views not accepted and the reasons for not accepting them

To be completed following the conclusion of the 30-day public comment period on May 3, 2016.

4. Additional summary:

TBD

PR-05 Lead & Responsible Agencies – 24 CFR 91.200(b)

1. List each agency/entity responsible for preparing the Consolidated Plan and the Annual Action Plan, and those responsible for the administration of each grant program and funding source.

Please see table below.

Agency Role	Name	Department/Agency
Lead Agency	City of Newton, MA	Housing and Community Development Division
CDBG Administrator	City of Newton, MA	Housing and Community Development Division
HOME Administrator	City of Newton, MA	Housing and Community Development Division
ESG Administrator	City of Newton, MA	Housing and Community Development Division

2. Introductory narrative:

The Housing and Community Development Division (the Division) in the City of Newton's Department of Planning and Development serves as the lead agency responsible for overseeing the drafting of the Consolidated Plan and the Annual Action Plans. In addition to operating as the lead agency for the City's CDBG and ESG consolidated planning process, the Division also serves as the lead entity for the HOME sections of the plan on behalf of the WestMetro HOME Consortium. The Consortium consists of the towns of Bedford, Belmont, Brookline, Concord, Framingham, Lexington, Natick, Needham, Sudbury, Watertown, and Wayland, and the cities of Newton and Waltham.

3. Annual Action Plan Public Contact Information:

Lydia Scott
 Community Development Planner
 Department of Planning and Development
 1000 Commonwealth Avenue
 Newton, MA 02459
lscott@newtonma.gov
 617-796-1132

AP-10 Consultation

- 1. Provide a concise summary of the jurisdiction's activities to enhance coordination between public and assisted housing providers and private and governmental health, mental health and service agencies.**

The City of Newton Housing and Community Development Division (the Division) of the Department of Planning and Development has developed and managed strong partnerships and relationships to enhance coordination between service providers, surrounding municipalities, and other city departments. Entities participating in the process include multiple providers of various types of services. These include agencies and organizations with expertise in case management, life skills development, alcohol and/or drug abuse counseling, mental health services, adult education, housing, employment assistance, child care, transportation, legal assistance, elderly programming, food/clothing, domestic violence, physical and allied health care. The jurisdiction's consultation with these providers involved information sessions during the Consolidated Plan process with numerous committees, boards, and task forces that all solicit citizen feedback. The sessions not only imparted information to the various working groups but also presented opportunities to receive criticism, questions and feedback. Anticipated outcomes include improved lines of communication, increased collaboration, and enriched citizen participation.

- 2. Describe coordination with the Continuum of Care and efforts to address the needs of homeless persons (particularly chronically homeless individuals and families, families with children, veterans, and unaccompanied youth) and persons at-risk of homelessness.**

The City of Newton is the lead entity in the Brookline-Newton-Waltham-Watertown (BNWW) Continuum of Care (CoC) and is responsible for submitting the CoC Consolidated Application for McKinney-Vento funds for homelessness assistance programs each year. The CoC was awarded Tier 1 grant renewals in the amount of \$1,353,675 in March 2016 (FFY15); this amount also includes the award of a \$60,046 Planning Grant to the City of Newton to assist with administration and strategic planning for the CoC. **The results of the Tier II grant awards are still pending.** These funds are awarded to programs that aim to reduce homelessness by assisting homeless individuals and families as they attain self-sufficiency and obtain permanent housing. The grants provide funds directly to six non-profit organizations: Advocates, Inc., Brookline Community Mental Health Center, Pine Street Inn, the Brookline Housing Authority, The Second Step, Inc., and Vinfen Corporation. Five of the 14 projects awarded Tier I funding will benefit Newton residents directly in FY17. Advocates, Inc., based in Framingham, received \$338,935 for lease payments and supportive services to assist up to 12 homeless individuals renting scattered site units in Newton. The Second Step, Inc., which is based in Newton and provides transitional housing and supportive services to survivors of domestic violence and their families, received \$360,004 for their housing programs at three different sites in Newton.

The City, in collaboration with the Town of Brookline, is also responsible for the annual Housing Inventory Count (HIC) and the Point-in-Time (PIT) census of homeless individuals and families. The sheltered count and the HIC were conducted from sundown on January 27, 2016 through sunrise on January 28, 2016. The communities of Brookline and Waltham also conducted an informal unsheltered count of known locations of homeless individuals on the same evening. Facilitating the PIT and HIC on an annual basis is the principal way in which the City systematically reaches out to the homeless and, once the data is tabulated, is able to assess their needs. Every December, the CoC provides valuable HMIS data to Newton staff for inclusion in the Annual Homeless Assessment Report that is later presented to Congress in the following year. Newton anticipates participating again in the AHAR during FY17.

Additionally, beginning with the release of the City's Housing Strategy in the spring of 2016, the City will begin the process to ultimately develop nine to twelve units of permanent supportive housing for the chronically homeless.

Across the Consortium, communities worked with their relevant City departments, local and regional organizations, agencies, churches, police, schools, housing trusts, housing authorities, food pantries, hospitals, shelters, veterans' service officers, social workers, and non-profits, as well as the Commonwealth's Department of Housing and Community Development, Council on Aging, and Department of Public Health to address the needs of homeless individuals.

3. Describe consultation with the Continuum(s) of Care that serves the jurisdiction's area in determining how to allocate ESG funds, develop performance standards for and evaluate outcomes, and develop funding, policies and procedures for the operation and administration of HMIS.

The City communicates and coordinates with the CoC concerning all services to be provided, performance standards, and policies and procedures for the operation and administration of the HMIS. Later in 2016, an annual request for proposals (RFP) will be released to publicly seek bids from qualified nonprofit or municipal organizations who wish to provide services under the emergency shelter, street outreach, homelessness prevention, and rapid rehousing components of the pending FY17 (FFY16) allocation of Emergency Solutions Grant (ESG) funds, after consultation with the CoC. The document will contain a description of all requirements placed on sub-recipients, which shall include policies on the following:

- Assessing all persons seeking services
- Verifying eligibility of program participants, and whether applicants meet the homelessness or at-risk of homelessness definitions established by HUD
- Prioritizing the need of applicants for ESG services
- Establishing the amount and length of time that financial assistance will be provided
- Determining a clear statement of the responsibility of sub-recipients to enter all client data in an HMIS—or alternate system for victim services providers—that has been approved by the Continuum of Care
- Detailing complete description of the duties and responsibilities of a case manager.

The RFP will be distributed as widely as possible. An announcement will go to all local agencies currently providing eligible services and to all participants in the Continuum of Care. An announcement of availability will be placed on the City's website. A due date for applications shall be clearly publicized along with the RFP. All potential applicants will be given approximately three to four weeks after the initial announcement to submit their applications. Potential applicants will be provided with all requirements and responsibilities to be assumed with receipt of sub-awards. Applications will be reviewed by the City of Newton Community Development staff, with input from a citizen advisory committee, and funding recommendations will be made regarding the most qualified service provider(s). A recommendation for these awards will be considered by the City's Planning and Development Board and after a 30-day comment period will be forwarded to the Mayor for final approval.

- 4. Describe agencies, groups, organizations and others who participated in the planning process and describe the jurisdiction's consultations with housing, social service agencies, and other entities. Agencies, groups, organizations and others who participated in the process and consultations.**

Division staff and the Consortium communities consulted with relevant City departments, local and regional organizations, and housing and other social service agencies throughout the development of the FY17 Annual Action Plan. Division staff also worked with current CDBG-assisted human services providers to get beneficiaries' input into the Plan, and heard feedback from staff of these agencies at Needs Assessment and Strategic Plan events during last year's drafting of the FY16-20 Consolidated Plan. This year's plan draws heavily on the needs assessment and outreach completed during the 18-month consolidated planning process.

Please see sheet AP-10: Consultation at the end of this section.

- 5. Identify any agency types not consulted and provide the rationale for not consulting.**

Staff attempted to contact and consult with all agencies and individuals involved in providing affordable housing units, supportive services, and infrastructure improvements in the City of Newton and throughout the Consortium. No one was purposefully excluded from contributing or commenting on the Annual Action Plan.

- 6. Describe other local/regional/state/federal planning efforts considered when preparing the Plan.**

Please see sheet AP-10: Other Plans Considered at the end of this section.

AP-12 Citizen Participation

1. Summarize the citizen participation process and how it had an impact on goal setting, as well as any efforts made to broaden citizen participation.

During last year's Consolidated Planning process, Division staff employed a number of methods to solicit citizen and agency input, including nine Needs Assessment presentation and discussion events, a Needs Assessment data presentation, and a meeting that summarized the input gathered during the Needs Assessment in May and June of 2014. In addition, the Division created an online and paper survey to provide another resource for people to share their input regarding needs in the community, and how they might prioritize those needs. Additionally, in response to the public comments received during the Needs Assessment, the Division staff put an emphasis on gathering the input of low to moderate-income people, current and potential beneficiaries of the CDBG, ESG, and HOME programs. During the 18 months of outreach, staff went to a number of events to spread the word about the Consolidated Plan and seek public input, including Nonantum Village Day, Newton Veteran's Service Center, and had a focus group with youth at the YMCA Teen Center. In addition, Division staff encouraged survey input from people who did not feel comfortable participating in a focus group, and received surveys from clients of The Second Step, Riverside Community Care, Family Access, JCHE, and others. Division staff also met with all the nine citizen advisory committees to share various aspects of the Consolidated Plan and receive input from members. Much of the data and information collected during this period was incorporated into the FY17 Plan.

In addition to the comprehensive collection of data, staff also discussed the AAP at various boards and commissions meetings throughout January and February, including the following: the Newton Fair Housing Committee; the Newton Housing Partnership; the Brookline-Newton-Waltham-Watertown Homelessness Continuum of Care; the Human Services Advisory Committee; and the residents of the Newton Corner Target Neighborhood. In accordance with HUD guidance and the City's Citizen Participation Plan, a public hearing was held for a review of the Plan by the City's Planning and Development Board on April 4, 2016. An accessible draft of the document was also made available on the City's website ten days in advance of the hearing.

The Towns of Bedford, Concord, Lexington, and Sudbury use public hearings at the Board of Selectmen meetings when broad public input is needed. These meetings are now televised and thus are available to more residents who may be unable to attend.

The Town of Belmont's Housing Trust held a public meeting to gather input from the residents on how to address affordable housing in the Town.

In Brookline, the Housing Division staffs the Brookline Housing Advisory Board (HAB), which holds monthly meetings to review all affordable housing projects being undertaken or considered by the Town. Content related to the FY17 Plan was discussed at the meeting on February 11, 2016. All HAB meetings are open to the public and advertised via the Town's web site and blog to all interested parties including all Town Meeting members.

In the Town of Framingham, a public hearing was held on September 22, 2015, to solicit community comments on the consolidated annual performance evaluation report while a needs assessment session was held with community stakeholders on December 1, 2015, to evaluate for social and municipal service gaps. The Community Development Department also revived its fair housing committee on January 19, 2016, to incorporate housing education into its work; it evaluated as well as decided on proposals submitted for FY17 public service RFP's in a public hearing on January 26, 2016. All of these processes informed decisions about HOME FY17 allocations and priorities.

The Town of Natick discussed securing additional resources for affordable housing at its Fall 2015 Town Meeting.

In Needham, the Planning Board held a public meeting to discuss the Town's Housing Strategy on September 1, 2015. This meeting was followed by a public meeting on October 27, 2015 that involved a joint meeting of the Planning Board and Board of Selectmen to discuss the Town's Housing Strategy in a "post 40B" era as the Town of Needham is poised to surpass the 10% affordability threshold under Chapter 40B in 2016.

The City of Waltham Planning Department held a public meeting on January 11, 2016, to gather input on this year's plan. Topics discussed included housing and community development needs and proposed use of funds for the upcoming year.

In Watertown, the Watertown Housing Partnership serves as the Town's policy body, whose volunteer members are appointed by the Town Manager to oversee the development and preservation of affordable housing in Watertown. The Partnership uses Email (Notify Me) to announce its meetings, as well as Agenda postings. They will also make a presentation to the Town Council on housing goals, and current development strategies. The Partnership approved the Watertown components of the FY17 Plan on January 19, 2016.

Please see sheet [AP-12: Citizen Participation](#) at the end of this section for detailed information on outreach.

Expected Resources

AP-15 Expected Resources - 91.420(b), 91.220(c)(1,2)

1. Anticipated Resources:

See sheet AP-15: Anticipated Resources at the end of this section.

2. Explain how federal funds will leverage those additional resources (private, state and local funds), including a description of how matching requirements will be satisfied:

The City will use federal funds to leverage additional resources in several ways. With respect to affordable housing projects, federal HOME and CDBG funds will be complemented with City-controlled Community Preservation Act (CPA) funding as well as funds collected as a result of the City's Inclusionary Zoning ordinance. CPA funding can also be used to produce mixed-income developments since this money can be used for housing units that are affordable to households earning up to 100% of AMI. Inclusionary zoning (IZ) funds are collected from developers of smaller-scale housing projects in lieu of providing affordable units on site. Again, these funds can be especially helpful in creating mixed-income developments, as the affordability limit for IZ funding is up to 120% of AMI in some instances. During the needs assessment meetings held in preparation for developing the *FY16-20 Consolidated Plan*, many participants, especially older adults, expressed the need for more mixed-income housing opportunities in the City. These developments should have market-rate, moderately-priced and restricted affordable units and be located in village centers or close to transportation and amenities. A combination of public investments using CDBG, HOME, CPA and IZ funding as well as other state investment (such as tax credits etc.) and private financing should enable these projects to be created in Newton.

In addition, respondents to the City's request for proposals (RFP) for CDBG Public Service funds must include the total program costs and provide a list of any other resources that will be used in conjunction with the CDBG funds.

Several of the Consortium communities will be repaying loans to other member communities during FY17. More detailed information can be found in the FY17 HOME Budget in the appendix of this Plan.

In the Town of Concord, the HOME funds allocated to the Peter Bulkeley Terrace project are being used as leverage to raise the \$630,000 in additional funding needed to complete the work. The HOME funds have encouraged the allocation of funds from the Town of Concord for local affordable housing projects (\$60,000) and have secured up to \$200,000 in State funding for the project. The federal funds have also been instrumental in securing a recommendation for local Community Preservation Act Funds to be used to cover the remaining \$370,804 necessary to complete the work. By leveraging these HOME funds, Concord has more than doubled the funding available for this project.

In FY17, the Town of Framingham expects to utilize leverage and match with its partnership with Preservation of Affordable Housing (POAH), on a \$14 million housing rehabilitation project that is partially financed by Framingham HOME funds.

All other Consortium communities will meet federal match and leverage requirements as necessary in FY17.

Annual Goals and Objectives

AP-20 Annual Goals and Objectives - 91.420, 91.220(c)(3)&(e)

1. Goals summary table:

See sheet AP-20: Annual Goals at the end of this section.

2. Narrative descriptions of goals specifically for FY17:

In FY17, CBDG funding allocated to the City of Newton will continue to be used for a variety of activities with respect to affordable housing. First and foremost, the City's Department of Planning and Development will have begun implementation of a City-wide Housing Strategy. This strategy will identify approaches and actions that will enable the City to achieve a minimum of 10% of Newton's housing stock affordable to low- and moderate-income households by 2021. The strategy will identify desirable locations for affordable housing as well as housing types appropriate for those locations. The strategy will also identify potential sites for the location of nine to twelve units of permanent supportive housing for chronically homeless individuals. These units could be created either on one site or on several scattered sites throughout the City. The Housing Strategy project began in FY16, and the City intends to have a final version by the start of FY17.

The City will consider funding the creation of new affordable housing units as developments are proposed and as resources as available, and will continue to run certain programs that were successful in FY16, as described below.

- In FY17, the City will continue to fund the Tenant-Based Rental Assistance (TBRA) program, which was successful in placing two families in rental homes in FY16. The City will issue a new voucher in FY17, and fund a second year of assistance for the two households selected in FY16. Staff will also make improvements in the marketing of the program so that applicants can find housing more easily within the City of Newton or the Consortium communities. The TBRA Program is targeted to assist families at or below 60% of the AMI and where possible direct the vouchers toward families experiencing homelessness.
- Staff will continue to market and administer the Housing Rehabilitation program and will expand the program to target the rehabilitation of existing accessory apartments that require repairs to ensure resident health, safety, and building code compliance.
- Staff will develop a program to encourage production of more affordable housing units through inclusionary zoning.
- The City will issue an RFP to allocate CBDG and HOME funds (and potentially inclusionary zoning funds), which will be used for the creation or preservation of affordable housing units. This could include providing subsidy to allow for deeper affordability or to create additional affordable units in inclusionary developments

beyond what is required. A funding preference will be for the creation of affordable units set aside for permanent supportive housing for chronically homeless individuals.

City staff will develop and host programs to educate elected officials, decision makers and the general public about Fair Housing in FY17, as well as work on other actions and strategies identified in the FFY15-FFY20 WestMetro HOME Consortium Regional Fair Housing Plan.

With respect to the Emergency Solutions Grant (ESG), \$159,211 in funding will be distributed through an RFP process for local agencies to provide shelter services, supportive services, rapid rehousing and transitional housing to homeless individuals and families and those who are at-risk of homelessness. HUD's stated priority for this funding is for rapid re-housing and the Brookline-Newton-Waltham-Watertown Continuum of Care (BNWW CoC) will consider this priority while also considering the greatest needs for this population in our immediate region. After input from the non-ESG funded agencies within the CoC, funding will be awarded based on responses to the RFP in summer 2016.

In FY17, \$291,375 will be allocated to 16 different programs to assist low- and moderate-income residents and families as well as persons with disabilities and seniors. The programs selected to be funded cover a wide range of services that will address the needs of these vulnerable populations and will help them meet the "Benchmarks for Success" model recently adopted by the City. The needs were identified in numerous community meetings about the FY16-20 Consolidated Plan and were confirmed by the Human Service Advisory Committee in November 2014 and again in March 2016.

Information re: target neighborhood improvement projects is TBD.

In FY17, \$87,125 will be allocated towards an architectural access project. This project, the FY17 Curb Cuts funding pool, will be used to fund curb cuts improvements at intersections City-wide, to improve accessibility for all residents. This project will operate only as a funding pool; once specific intersections are identified, new project budgets will be set up internally and in IDIS, without invoking the substantial amendment process as defined in the Citizen Participation Plan. Division staff is working with the City's ADA Coordinator to explore new access projects as well, including improvements to the Newton Free Library. Once the feasibility of these projects is determined, they may be set up and funded at a later date.

The FY16-20 Consolidated Plan set a goal for job training and job creation for low- and moderate-income (LMI) individuals. In FY16, staff reached out to create partnerships with local businesses and institutions in an attempt to develop a program to train LMI individuals for available jobs in the community. However, the program proved more difficult to create, as the majority of the large employers within Newton, like Boston College or Newton-Wellesley Hospital were unable to participate because their non-profit status rendered them ineligible for special economic development activities. Division staff will not officially pursue this goal in FY17.

Many of the Consortium communities identified the creation of new affordable housing, Tenant Based Rental Assistance, and rehabilitation of PHA, ownership, and rental units.

Because of market conditions in Brookline, the Town is experiencing tremendous development pressure – with a number of developers planning to build additional housing units. It is likely that the Town will be reviewing a number of Inclusionary Zoning and 40B development proposals during FY17, all of which will produce between 15% and 25% affordable units. These projects could produce a significant number of affordable units.

In FY17, Brookline’s Housing Division plans to complete a Housing Production Plan which will outline the Town’s strategy for creating new affordable housing. An outside consulting firm was hired to manage this planning process, which includes focus groups, stakeholder interviews, community forums, and presentations before the Board of Selectmen in order to garner maximum resident input of the Town’s affordable housing plan. The Housing Production Plan will be submitted to the State’s Department of Housing and Community Development to receive approval and certification.

The Town of Concord has committed HOME funds to assist in the construction of four new units at the Peter Bulkeley Terrace Senior Housing development, and will continue to work on this project.

There are no FY17 goals for the Town of Needham included in this Plan.

There are no FY17 goals for Sudbury, as funds in the FY17 periods will be used to repay Natick for funding that was borrowed to assist with financing the completed Coolidge at Sudbury project.

AP-35 Projects - 91.420, 91.220(d)

1. Project information table:

See sheet AP-35: Projects at the end of this section.

2. Describe the reasons for allocation priorities and list any obstacles to addressing underserved needs. List proposed actions to overcoming those obstacles.

Division staff has allocated CDBG funding to five general categories: Housing/Homelessness, Human Services/Public Services, Neighborhood Improvements, Architectural Access, and Program Administration. These categories are funded based on the priorities and needs detailed in the FY16-20 Consolidated Plan.

Housing/Homelessness

The majority of funds (approximately 55 percent) will be allocated to the category of Affordable Housing/Homelessness. This funding will be used to facilitate rehabilitation, acquisition, and rental assistance for low- and moderate-income households.

Human Services/Public Services

The City intends to allocate the maximum allowable amount of 15 percent for this category.

Neighborhood Improvements

This project category will receive a five percent allocation in FY17. Neighborhood projects can include, but are not limited to, improvements to sidewalks, pedestrian safety, intersections, community amenities, parks, and public facilities. These projects will be completed in the areas of the City that have the highest concentration of low- and moderate-income individuals.

Architectural Access

Five percent of the City's annual CDBG allocation will be directed towards architectural access projects this year. These projects that enhance accessibility for persons with disabilities can be completed Citywide, without geographic restriction.

Program Administration

We intend to allocate the maximum allowable amount of 20 percent for program administration.

AP-50 Geographic Distribution - 91.420, 91.220(f)

1. If your community uses geographic target areas as a basis for funding allocation priorities, describe the target areas that will receive assistance:

In the FY16-20 Consolidated Plan and the FY16 Annual Action Plan, Division staff identified five “target neighborhoods” in which to allocate CDBG funding for area-benefit activities: Newton Corner, Nonantum, Newtonville, West Newton, and Upper Falls. This designation was based on the geographic boundaries of the eligible census block groups that met or surpassed the required LMI threshold as determined by HUD LMIS data. With the release of the new LMIS data in 2014, portions of existing target neighborhoods were no longer eligible, while new census blocks throughout the City became eligible. Blocks groups are considered eligible if comprised of greater than or equal to 30.68% low- and moderate-income residents. Most notably, there was an expansion of the West Newton, Newtonville, and Newton Corner boundaries.

A fifth target neighborhood was created for a newly eligible block group in Upper Falls, and included as the neighborhood to receive funding for FY16. It was determined by staff, however, that this neighborhood will be excluded from the program and funding cycle in the future. Because of its proximity to neighboring block groups that do not contain a minimum of 30.68% low- and moderate-income residents, staff was unable to justify any new projects when performing service area calculations. Multiple calculations demonstrated a larger service area that did not primarily benefit low- and moderate-income residents as they did not meet the overall required threshold necessary for eligibility. The previously allocated FY16 funding of \$88,431 will be re-programmed to another eligible activity, project, or neighborhood.

Previously, the funding for neighborhood improvements has operated on a six-year alternating rotation. Newton Corner and Nonantum each received funding once every three years, while Newtonville and West Newton each received funding once every six years. With the introduction of the additional neighborhood, each target area would receive funding once every five years for the duration of this Plan. Though Upper Falls will be excluded for the remainder of the Consolidated Plan, a five year funding cycle will remain in place. However, the order will be rearranged to allow for adequate time for West Newton to develop projects and a committee, since its boundaries were completely revised with the 2014 LMIS data. Newton Corner will be the target neighborhood for the FY17 plan.

Information re: FY17 neighborhood project TBD.

Community Development Department staff in the Town of Framingham use census tract information to determine whether to target a specific area of the community with HOME funds. With this strategy, HOME funds are designated for use in census tracts 383600.2, 383501.2, 383300.1, 383400.3, 383400.2, 383200.4, 383200.1, 383101.2, 383101.1, 383102.1, and 383102.2. These tracts house the highest number of low- and moderate-income residents.

No other Consortium communities identify target geographic areas.

2. Describe the rationale for the priorities for allocating investments geographically.

Division staff will lead a multi-departmental team to engage the community in identifying and selecting projects. See above and section SP-10 in the Strategic Plan chapter of the FY16-20 Consolidated Plan for more information on the designation of the target neighborhoods, and see the Citizen Participation Plan in the appendix for more information.

Please see above, and the map below, for the Town of Framingham’s rationale.

No other Consortium communities identify target geographic areas.

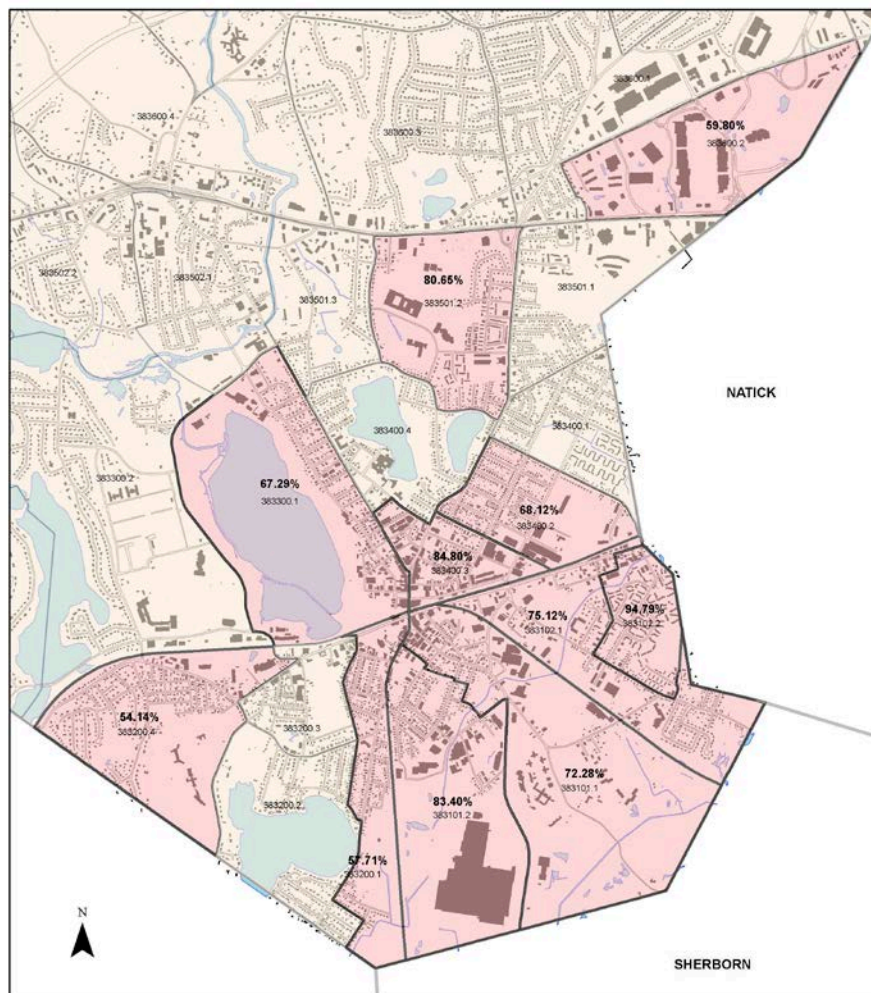

□ Census 2010 Tracts - Framingham
□ Census 2010 Block Groups - Framingham

Framingham CDBG Target Areas
MassGIS 2010 Census Data
Framingham, MA

September 2014
Prepared by Community & Economic Development

Affordable Housing

AP-55 Affordable Housing - 91.420, 91.220(g)

1. Narrative:

The focus in FY17 will be on implementing a City-wide Housing Strategy. The City has engaged a consultant to provide a report to the Mayor and City Council on the housing strategy, which will be completed in FY16 and will be used by the City to develop concrete actions. This strategy will identify approaches and actions that will enable the City to achieve a minimum 10% of Newton's housing stock affordable to low- and moderate-income households by 2021. It is the City's expectation that the strategy will identify desirable locations for affordable housing. City staff will also identify potential sites for the location of nine to twelve units of permanent supportive housing for chronically homeless individuals. These units could be created either on one site or on several scattered sites throughout the City.

The Division will also continue to fund Housing Rehabilitation Program projects with the anticipation that ten units will be rehabilitated in FY17. The Division will focus particular outreach efforts to homeowners that may have an accessory apartment that requires rehabilitation.

The Tenant-based Rental Assistance (TBRA) Pilot Program, launched in FY15, successfully housed two families in Newton and Waltham by February 2016. The TBRA Program improves the transition for homeless households currently living in hotels that double as overflow emergency shelters to more stable housing within Newton or in other Consortium communities. Division staff plans to re-capitalize the program in FY17, and assist one additional family this year, as well as provide a second year of assistance to the two households funded in FY16.

In 2014, Newton's inclusionary housing ordinance was revised to allow an applicant to utilize public subsidy to increase affordability within a project after the 15% affordable unit requirement is achieved. The program will build on this framework to provide a subsidy source that would fund the creation of additional affordable units, provide a deeper level of affordability of existing units, and/or create physical accessibility beyond what is required by state and federal accessibility law without necessarily expanding project density. The program can also assist developers with the additional cost of providing affirmative marketing and income certifications and with technical assistance.

In FY17, The City will issue an RFP to allocate CDBG and HOME funds (and potentially inclusionary zoning funds), which will be used for the creation or preservation of affordable housing units. This could include providing subsidy to allow for deeper affordability or to create additional affordable units in inclusionary developments beyond what is required. A funding preference will be for the creation of affordable units set aside for permanent supportive housing for chronically homeless individuals.

The Town of Bedford plans to assist four households with financial rental assistance in FY17.

The Town of Belmont anticipates a large number of housing units to become available in FY17, including affordable units. The Belmont Uplands (298 rental units with 20% affordable) will begin leasing in spring 2016. Cushing Village (115 rental units with 10% affordable) expected to conclude the financing process in spring 2016, and subsequently begin construction. These two projects will provide a significant increase in the supply of both market and affordable rental housing.

In Brookline, a total of 144 new units of affordable rental housing will be produced in Brookline during FY17. Thirty-one (31) enhanced SRO units at the Beals Street project, which will primarily serve single-person households who were formerly homeless. This project was started in FY15 and its expected that Pine Street will close out the project in FY17, with the project fully occupied. The 40B mixed-income project at Marion Street is also expected to complete its construction and marketing by early FY17, and provide 13 total affordable units. Lastly, the Town is working to identify a new affordable rental development project to begin in FY17 while responding to a number of 40B proposals, which will add affordable units once the comprehensive permit process is complete.

The Town of Concord has a history of supporting efforts to establish and maintain affordable housing. The Town currently has 710 affordable units, with 10.36% of its housing included in the Commonwealth's Subsidized Housing Inventory (SHI).

Though it receives a limited annual allocation of approximately \$20,000, the Town of Lexington hopes to assist one unit of rental housing. The Natick Affordable Housing Trust is using several previous years' HOME allocations for several rehab projects in FY17. The Coolidge House Congregate building is being converted from 18 SRO units to 10 one-bedroom units, and will eventually be leased to the Massachusetts Department of Mental Health. The second project is the two-family home on Plain Street, which has been vacant for over a decade, and will be rented to families served by the Natick Housing Authority.

The Town of Wayland has been working on the development of affordable rental housing, concentrating on the proposed River's Edge Project over the last 3 years. The site consists of approximately 8 acres of town-owned land. An initial RFP was issued and unfortunately no bids were received. The Town of Wayland plans to reissue the RFP in spring 2016. If a contract is awarded in FY17, this development would produce 190 units, of which 47 will be affordable.

2. Please complete the table below:

One Year Goals for the Number of Households to be Supported (By Population Type)	
Population Type	Number of Households
Homeless (units reserved for homeless individuals and/or households):	45
Non-Homeless (for all units NOT reserved for homeless individuals and/or households):	293*
Special-Needs (units reserved for households that are not homeless but require specialized housing or supportive services)	17
Total (Consortium-wide) >>>>	355

NOTE: Units that are acquired and rehabilitated are only reported once under either rehabilitation or acquisition.

* 60 of these units are associated with the Belmont Uplands development, which is expected to begin leasing in spring 2016. 12 of these units, to be located at Cushing Village, depend on the developer securing the necessary financing. Three of these units reflect first-time homebuyer participants, and depend on securing homes within their price ranges.

2. Please complete the table below:

One Year Goals for the Number of Households Supported Through (By Program Type)	
Program Type	Number of Households
Rental Assistance (for programs such as TBRA and one-time payments to prevent homelessness):	70
The Production of New Units (construction of new units, including conversion of non-residential properties):	203*
Rehab of Existing Units (including reconstruction):	75
Acquisition of Existing Units (for programs such as downpayment assistance):	7
Total (Consortium-wide)>>>>	355

NOTE: Units that are acquired and rehabilitated are only reported once under either rehabilitation or acquisition.

* 60 of these units are associated with the Belmont Uplands development, which is expected to begin leasing in spring 2016. 12 of these units, to be located at Cushing Village, depend on the developer securing the necessary financing. Three of these units reflect first-time homebuyer participants, and depend on securing homes within their price ranges.

AP-60 Public Housing - 91.420, 91.220(h)

1. Briefly describe any actions planned to address the needs of public housing residents. Indicate if any funded projects will address the needs of public housing residents.

The Newton Housing Authority is currently working on expanding its resident services program with the addition of a licensed social worker on staff. CDBG funds continue to support the resident services program and address accessibility needs for residents. Capital needs are assessed at all properties annually and emergency and preventative maintenance is used to address needs as they arise.

CDBG housing rehabilitation program funds are available as applicable for improvements and emergency maintenance for Newton Housing Authority properties.

Last year in FY16, the Bedford Housing Authority launched its Social Service Program to connect families to the resources necessary to stabilize the living situation and improve quality of life. The program will provide financial literacy education, skill training, career coaching, and other support services to up to 15 low-income households currently residing in Bedford PHA units.

In FY17, the Town will begin to examine the Brookline Housing Authority's goals for rehabilitating two large family developments of state-owned public housing to identify ways in which the Town might provide support and preserve these units. The two developments contain a total of 306 units and are in need of substantial rehabilitation.

In Concord, the Town works closely with the Housing Authority on its two current HOME projects. The first is the implementation of a HOME-funded project for necessary repairs at 282-294 Thoreau Street, a four-house rental development owned by the CHA. The second project combines HOME funds with state and local funds to construct four new units at the CHA's Peter Bulkeley Senior Housing Development.

In FY17, the Town of Framingham will support its PHA through a contribution of HOME funds for the acquisition and rehabilitation of blighted property.

The Natick Housing Authority is focused on the successful rehabilitation of two properties using HOME funds: Coolidge House and 6 Plain Street in FY17.

Though not yet ready for funding FY17, the Town of Needham will support its PHA with the redevelopment of the 152-unit Linden-Chambers project to rehabilitate existing units and create additional units.

Beginning in FY16 and continuing in FY17, the City of Waltham will be working with the Waltham Housing Authority to contribute HOME funds to rehabilitate 80-86 Orange Street, a WHA property.

In Watertown, the Housing Authority is working with the MA Department of Housing and Community Development to administer a new state initiative implemented in FY 2015 called

Mass Learning, Employment and Asset Program (MA LEAP). This program's primary goal is to increase the earned income of public housing residents through measurable, targeted improvements in several areas: Post-Secondary Education; Career Planning and Employment; Financial Literacy and Asset Development. The Watertown Housing Authority is one of five housing authorities in Massachusetts participating in this Five (5) Year Pilot program and has, to date, enrolled twenty-one (21) residents.

2. Briefly describe any actions planned to encourage public housing residents to become involved in management and to participate in homeownership programs. Indicate if any funded programs will address the needs of public housing residents.

The Newton Housing Authority does not participate in any homeownership programs. Residents are involved in the PHA Plan and capital needs process through annual tenant meetings and communication with the Resident Advisory Board.

In Bedford and Lexington, residents gather in the Community Building monthly for a social event. In the Town of Belmont, the PHA holds bi-monthly meetings at each of its developments, where time is set aside for residents to voice any concerns. When a major improvement is proposed for a specific development, residents of that development are encouraged to actively participate in providing feedback on the proposed improvement.

In Brookline, as any affordable homeownership unit becomes available through turnover, the Town's Housing Division manages this resale process and engages in extensive outreach and a lottery process. Public Housing tenants interested in homeownership opportunities are notified through the Housing Authority or by signing up for the Town's affordable housing list serve. A number of public housing tenants have taken advantage of these opportunities in the past.

In Framingham, the Town's Fair Housing Committee is organizing public forums on housing rights and education for public housing residents.

The Watertown Housing Authority has an active Tenant Association and Resident Advisory Boards (RABs) in the Family and Elderly developments. The Authority communicates all Capital need plans and operational issues to all the resident groups. As noted above, the Authority is also a member of the MA LEAP Program to enhance resident employment and life skills.

3. If the PHA is not designated as "troubled," indicate "Not Applicable." If the PHA is designated as troubled, briefly describe any assistance the jurisdiction will provide to help the PHA clear the troubled designation.

Not applicable. No PHAs in the Consortium have been designated as "troubled."

AP-65 Homeless and Other Special Needs Activities - 91.420, 91.220(i)

For the following questions, describe the link between your community's one-year goals and actions for reducing and ending homelessness.

12. Describe actions planned to address reaching out to homeless persons (especially unsheltered persons) and assessing their individual needs.

- Continue to Allocate Emergency Solutions Grant funds for a Street Outreach Program and Allocate Additional Funds towards Homelessness Prevention

In FY15 and FY16, the City provided Emergency Solutions Grant funding for Street Outreach within the BNWW Continuum of Care Service Area (CoC). Brookline Community Mental Health Center was awarded the grant, and a dedicated case worker conducts the outreach. The goal is to seek out unsheltered individuals and families with the goal of connecting them with emergency shelter, housing or critical services and non-facility-based care for those unwilling or unable to access appropriate housing. At the conclusion of FY15, 11 unsheltered individuals were identified and assisted through this funded category. The Street Outreach Program has proven to be successful, so the Jurisdiction, collaborating with the BNWW CoC, will continue this effort in FY17 with an increased percentage of funds.

Through an extensive evaluation of outcomes of programs, providers, and individual cases, as well as an examination of the existing real estate market within the CoC's geography, Division staff, in coordination with the CoC, has chosen to allocate more funding towards Homelessness Prevention in FY17. Staff believes Homelessness Prevention is an effective method to reduce homelessness.

- Utilize, Evaluate and Adapt the Continuum of Care's Coordinated Entry System

CoC members have begun to finalize the process for the implementation of its Coordinated Entry System, which will provide a standardized intake and assessment process for each service provider in the CoC's network using a "no wrong door" approach. With a Coordinated Entry System in place, each provider within the CoC is able to conduct a general assessment of the person's needs and make the appropriate referral to connect them with housing and/or the appropriate services. In the spring of 2016, the CoC, along with Division staff, will be working with technical assistance providers from The Cloudburst Group to assess and execute a pilot version of the system.

Consortium Communities:

Though homelessness is not a significant issue in the Town of Belmont, the Town operates a food pantry that is opened twice a month. This interaction allows staff to see if clients need further assistance, and can provide referrals to appropriate agencies.

In Concord, homeless individuals have occasionally taken up residence in the Town's public woods. When this occurs, the Town's Natural Resources Division, which oversees this land, works with the Community Services Coordinator and the Health, Fire, and Police Departments to identify, assist, and relocate these individuals and their belongings.

The Town of Framingham participates in the Balance of State Continuum of Care, and also coordinates efforts between City Departments (e.g. Veterans' Services) and local non-profits (e.g. Voices Against Violence) to better understand the needs of the homeless population and deploy resources as needed through a referral-based process.

The Natick Affordable Housing Trust uses funds to provide emergency hotel vouchers to individuals who become homeless unexpectedly.

All consortium communities coordinate with local agencies and municipal departments to refer individuals and families who are homeless, or at-risk for homelessness, to appropriate programs, resources, and services.

In the City of Waltham, Police and a Bristol Lodge Street Outreach Specialist reach out to unsheltered individuals frequently in the City and wooded areas. The Outreach Specialist works 19 hours/week with a six-person Police Task Force, which helps connect identified homeless individuals to services.

13. Describe actions planned to address emergency shelter and transitional shelter needs for homeless individuals and families, including domestic violence shelters, youth shelters, and hotel/motel voucher arrangements.

- Review Shelter Services Allocation from the Emergency Solutions Grant

Division staff utilizes ESG funds for various shelter services, including those for survivors of domestic violence and men's and women's emergency shelters. ESG funds are also awarded to the only day shelter in Waltham, which provides warmth, food, case management, counseling, legal services and referrals to appropriate service providers. ESG funds serve as a valuable resource these emergency shelter providers, especially since those types of projects are not eligible to receive McKinney-Vento Act funds. The Pine Street Inn runs several projects within the CoC and has an experienced outreach team that engages those choosing to not utilize a shelter and provides the individuals with referral information, food, clothing, hygiene products, and blankets.

However, thousands of families live in shelters and motel on a given night. Both the federal government and the CoC have established goals of ending family homelessness within five and ten years, respectively. Division staff will carefully evaluate the appropriation of Emergency Solutions Grant funds towards the rapid rehousing and homelessness prevention components of the ESG program, which can help reduce the number and duration of homelessness for families. Although there is a clear need and benefit of providing the shelter services, the CoC

must evaluate how to create housing stability and economic mobility in order to end homelessness.

- Issue additional tenant-based rental voucher(s)

In FY15, the City funded the Tenant-based Rental Assistance Program (TBRA), and two households were selected and funded in FY16. Under this pilot program the funds provide rental subsidy and support services for income-eligible households currently living in the Commonwealth's overflow emergency shelters. The program is predicated on the goal of coupling the housing with supportive services geared toward economic self-sufficiency. Since the program has proven successful thus far, the Division will issue one new voucher, in addition to funding a second year for the existing two households, in FY17.

Consortium Communities:

The Town of Belmont does not contain any emergency shelters, transitional housing, or other permanent housing specifically for homeless individuals and families. The Belmont Housing Authority provides emergency housing for income-eligible families who have lost their homes to fire or other catastrophe.

In the City of Waltham, homeless service providers and City staff manage a minimum barrier overnight homeless shelter for men and women aged 18 and older. The homeless shelter opens December through March between the hours of 8pm and 8am on days when the temperature reaches 32 degrees or below, or in the event of inclement weather like snow or freezing rain.

14. Describe actions to support:

a. The transition from shelter or transitional housing to permanent or independent housing

- Finalize and Review Housing Strategy to identify sites for permanent supportive housing

Following the directive of the United States Interagency Council on Homelessness (USICH) and the CoC's 2014 Ten-Year Plan to End Homelessness, the City's Department of Planning and Development is focused on developing permanent affordable housing with supportive services. The Housing Strategy, which began in the summer of 2015 and will be completed in spring 2016, will identify potential sites for the location of nine to twelve units of permanent supportive housing for chronically homeless individuals over the next four years. These units could be created either on one site or on several scattered sites throughout the City.

- Prioritize existing beds for chronically homeless individuals

This year, recipients of federal McKinney-Vento Homelessness funds within the BNWW CoC reconfirmed the commitment to prioritizing existing permanent supportive housing beds for chronically homeless individuals upon turnover. Participating organizations include Pine Street

Inn, Advocates, and Vinfen. Twelve of these beds are located within Newton. The CoC will continue this prioritization in FY16.

b. Shortening the period of time that individuals and families experience homelessness

The Division will continue utilizing ESG funding for Rapid Rehousing projects to quickly connect individuals and families with the support they need to exit homelessness and ensure housing stability. City staff and the CoC will continue to assess the challenges of the existing rental market within the CoC communities of Brookline, Newton, Waltham and Watertown to determine the feasibility of scaling up this approach through local partnerships.

c. Preventing individuals and families who were recently homeless from becoming homeless again

- Utilize Emergency Solutions Grants for Homeless Prevention and Rapid Rehousing
- Educate service providers and CoC communities about available funds

The Division will continue to utilize ESG funding for Homeless Prevention to reduce the number of individuals and families who are evicted from housing. These funds not only provide the financial resources to keep at-risk households housed, but it also provides the supportive services to help stabilize the household and ensure successful tenancies.

- Research and disseminate best practices for working with at-risk populations
- Identify and engage job training and employment services providers

A central goal of the BNWW CoC Ten-Year Plan to End Homelessness is to reduce the number of individuals and families becoming homeless through the provision of appropriate supportive services and financial assistance. Engaging, educating and seeking cooperation with key stakeholders regarding decreasing risk factors leading to homelessness will accomplish this goal. Key partners will also be needed to ascertain and ensure that appropriate services are available to adequately engage in the prevention of homelessness and to support previously homeless individuals and families experiencing community integration issues.

15. Describe actions planned to address the prevention of homelessness for those with the greatest need:

Creating and preserving permanent affordable housing opportunities that integrate supportive services will help individuals and families with the greatest need. Specific actions to be undertaken in FY17 include:

- Completion of a Housing Strategy that will identify approaches and actions that will enable the City to reach its goal of achieving a minimum of 10% of Newton's housing

stock affordable to low- and moderate-income households by 2021. The Strategy will also identify potential sites for the location of nine to twelve units of permanent supportive housing for chronically homeless individuals. These units could be created either on one site or on several scattered sites throughout the City.

- Target ESG funds toward homeless prevention programs.
- In conjunction with the Town of Brookline and the Brookline Mental Health Center, research and disseminate best practices for working with at-risk populations.

Consortium Communities:

The Massachusetts Department of Social Services and Department of Mental Health provide 83 units of housing in Belmont. The majority of these units are occupied by persons with mental and/or physical disabilities. Additionally, McLean Hospital, a psychiatric hospital located in the Town, provides services within the community to ensure that patients have access to appropriate supportive housing and services necessary to reduce recidivism.

The City of Waltham allocates CDBG funds for homelessness prevention.

AP-75 Barriers to affordable housing - 91.420, 91.220(j)

- 1. Describe actions planned to remove or ameliorate the negative effects of public policies that serve as barriers to affordable housing such as land use controls, tax policies affecting land, zoning ordinances, building codes, fees and charges, growth limitations, and policies affecting the return on residential investment:**

One of the biggest obstacles to affordable housing in Newton is the antiquated Zoning Ordinance. Particular zoning and other City policies that limit affordable housing include the following:

- A special permit from the City Council is required to create any multi-family housing (i.e. more than two units). The special permit process adds time and cost to these types of developments that could otherwise more easily create affordable housing units, and the process is highly political.
- Accessory apartments are often more affordable to rent because they tend to be smaller, but the process for approval of these units is cumbersome and often requires a special permit from the Board of Aldermen. As a result, it is estimated that there are 1000 illegal accessory apartments in the City all of which have not been properly inspected for compliance with the State Building Code and may pose serious health and safety concerns for occupants. In a step in the right direction, the Ordinance was recently changed to permit some illegal units more easily, which can be proven to be pre-existing from 1999, to be legalized if they can be made code compliant.
- Neighborhood opposition to large-scale affordable housing projects has also been a barrier to providing additional subsidized units and residential investment. In July 2013, the City adopted an amendment to its Citizen Participation Plan in an effort to inform the general public and abutters early on in the process of permitting an affordable housing project so that their input can be included in the design at an early stage.

Revision to Homeowner Rehabilitation Program

The Newton Homeowner Rehabilitation Program will place greater emphasis on targeting assistance to correct code violations for pre-existing accessory apartments. Rental income from these apartments can help low- and moderate-income owners make mortgage payments and also offer “naturally affordable” small housing units for low- and moderate- income renters that are identified in the Needs Assessment chapter as a means toward encouraging diversity in the City’s housing stock.

Fair Housing

Actions anticipated for addressing concerns regarding fair housing include the following:

- Post a Fair Housing Statement on the City of Newton's website. This statement is also be made available in other City documents and venues related to City-sponsored activities to abutters of pending development, zoning, or other actions affecting housing. The City intends to include that statement in all notice to abutters.
- Provide, in writing, a Fair Housing Statement, with the purpose of informing the public of the City's responsibility to Affirmatively Further Fair Housing.
- Provide Disparate Impact Education annually to City Councilors, City staff involved in activity relating to housing, and the public.
- Include the US Department of Housing and Urban Development's Fair Housing logo on all housing-related documents.
- Continue utilization of the discrimination reporting tool on its website, and to encourage the reporting of potentially discriminatory action, especially by encouraging nonprofit housing providers in the City to report acts of potential discrimination, as well as follow its procedures to be responsive to the reporters of such potential discrimination.
- Post information on the Planning and Development Department website page to guide the public and developers on the process for developing affordable housing projects in Newton. The posting will include information on fair housing and the City's obligation to affirmatively further fair housing. The City will have its Planning Department review all applicable projects for their inclusion of fair housing goals and note in writing in all applicable project reviews a statement that "the objectives of the City's Consolidated Plan, including fair housing, have been considered in this review"

Consortium Communities

In June of 2015, the City of Newton and the WestMetro HOME Consortium submitted its Regional Fair Housing Plan for the years FFY (federal fiscal year) 2015-2020.

The Town of Bedford also completed its Analysis of Impediments to Fair Housing Choice in 2013, which outlined five key barriers to affordable housing: lack of accessory apartments; monitoring and maintenance; density and cluster developments; parking; and other ongoing efforts. Town staff will continue to examine the Accessory Apartment Bylaws to determine how to increase the number of accessory units. Staff will work with the Regional Housing Services Office (RHSO) to fulfill monitoring requirements, as well as seek out additional affordable housing opportunities to create units within existing zoning guidelines. Finally, staff will review zoning bylaws to gain a better understanding of the impact of parking standards on affordable

housing development, and promote fair housing and encourage the recruitment of minority applicants to Town boards and committees.

The Belmont Housing Trust is working to complete a Housing Production Plan (HPP) that will look at housing issues in Town and identify goals, objectives and strategies to meet the Town's housing needs. The HPP will also lay the groundwork for updating the Zoning By-laws that specifically relate to regulating housing options. It is expected that the HPP will call for increased housing opportunities in Town and identify several zoning amendments to achieve this goal. The Belmont Housing Trust will work with the Planning Board and the developer of Cushing Village to insure that the approved development, a mixed-use, 115 unit development with 12 units of affordable housing units, will be built as permitted and required by the Town's Inclusionary Housing By-Law.

Brookline will continue to use its Zoning Bylaw proactively to encourage affordable housing as part of a market-rate project through its inclusionary zoning provision. Its Housing Advisory Board may explore options to allow Accessory Dwelling Units in conjunction with the Brookline Community Aging Network. The Town may explore also the use of Zoning Overlay District to encourage the development of new mixed-income housing to serve seniors.

To address identified impediments, Concord proposes three specific actions. First, Concord will address the high cost of existing housing and shortage of available land by working with the Concord Housing Development Corporation to develop affordable housing on former State lands in West Concord; using CPA funding to restore the affordability of units at the Emerson Annex building when they become available and establish new affordable housing restrictions; assisting the CHDC's Small Grants Program to help low and moderate level homeowners make necessary safety and other improvements to their existing homes; and utilizing HOME funds to rehabilitate and improve the accessibility of existing affordable housing units and create new units when possible. The Town will also continue to support the work of the Concord Housing Authority and of the Concord Housing Development Corporation wherever possible.

Second, to address local policies which limit development, the Town will encourage development which provides new affordable units dispersed widely throughout the community; consider new Smart Growth legislation and other models for developing housing within the community; encourage mixed use developments which provide some affordable housing at close proximity to transportation and community services; and, provide guidance and assistance to existing affordable housing homeowners and potential developers in identifying energy efficient programs and incentives to defray the cost of new construction and reduce overall housing costs.

Third, Concord will address its limited water and sewer infrastructure issues by seeking State and Federal approvals to increase the capacity of the existing waste water treatment plant using its current release systems; revising the Public Works Commission's "capacity allowance model" and other Town regulations; and, continuing efforts to identify and acquire additional land for the construction of a second waste water treatment facility.

The Town of Framingham operates with an inclusionary zoning bylaw that addresses many impediments to fair housing. This law requires 10% of units in housing developments with 10 or more units to be affordable to household at or below 80% of AMI.

The Town of Lexington completed its Analysis of Impediments to Fair Housing Choice in 2013. The single largest barrier to fair housing choice in Lexington is its high cost of entry, as a result of the relative scarcity of housing units combined with the high regional demand. In 2014, the Lexington Board of Selectmen completed the Housing Production Plan for the Town.

Natick faces the barriers of the high cost of construction and high demand for property, which make it difficult to maintain and develop housing that is affordable to a diverse population. Natick has seen several 40B, 40R and local HOOP projects which encourage developers to provide affordable housing while developing these cost restrictive properties. Natick also promotes zoning bylaws which encourage the further development of affordable housing, including the expanding of 40R and HOOP districts and implementing Inclusionary Zoning. The Town is also exploring the creation of “Tiny Houses” to provide low-cost housing.

Given limited developable property and zoning constraints, the Town of Needham is promoting rental redevelopment projects in primarily commercial areas, where higher densities are more appropriate and where housing can create a “work, live and play” environment. For example, the Town is working with developers of property in Needham Crossing, a major business park, to develop some of their recently acquired property for residential use, including affordable housing. This project has been processed through the state’s Local Initiative Program (LIP), the “friendly Chapter 40B” alternative, to override local zoning. The Town’s Zoning Board of Appeals recently approved the developer’s comprehensive permit application involving the creation of 390 rental units, 98 of which will be affordable based on state LIP requirements. The Town also recently approved a 136-unit Chapter 40B rental development on Greendale Avenue that will include 34 affordable units.

A new Mixed-Use Overlay District (MUOD) is also being prepared to promote mixed uses, including a mandate for including affordable housing, in an area in proximity to Route 128 and Highland Avenue that is appropriate for higher housing densities and mixed residential and commercial uses. Town Meeting is expected to rule on this new zoning at its spring 2016 meeting.

Sudbury completed an Analysis of Impediments to Fair Housing Choice in 2013, and identified three key barriers to housing: zoning, high cost of land, and lack of community support.

In FY17, the City of Waltham will utilize its HOME budget this year towards the removal of architectural access barriers within the existing affordable housing stock to increase the number of units available for low-income residents with mobility impairments.

Watertown amended its Inclusionary Zoning Ordinance by increasing the set-aside in late 2014 from 10% to 12.5%. Watertown is also considering further increasing the set-aside percentage in the proposed new Regional Mixed Use District from 12.5% to 15%. A possible barrier to the development of Affordable Housing is the relatively high parking requirement for studios, two- and three-bedroom units. Though the adopted Design Standards and Guidelines process, Watertown has lowered the parking requirements for multi-family developments.

The Town of Wayland is pursuing Chapter 40B developments to override local zoning and provide additional affordable housing units. The Town has initiated an affordable accessory apartment program that provides incentives for homeowners to rent to Section 8 voucher holders.

AP-85 Other Actions - 91.420, 91.220(k)

1. Describe actions planned to address obstacles to meeting underserved needs:

Please refer to section AP-35: Projects.

Though in the very early stages, the Town of Bedford intends to work with the U.S. Coast Guard to assess land it owns in Bedford that may become available for development.

Many of the Consortium communities will continue to work with staff, developers, consultants, and property owners to look for affordable housing development opportunities.

The Town of Framingham staff is working with the MetroWest Regional Transit Authority (MWRTA) to expand both hours of operation and routes to provide better transportation options to residents.

In the City of Waltham, 13% of the lowest income census tract is made up of non-English speaking residents, which creates a barrier between service providers, potential employers, potential landlords, and the residents. Waltham works closely with applicants of the TBRA program and social service providers to ensure the non-English speaking population understands the program and is able to apply.

2. Describe actions planned to foster and maintain affordable housing:

Please refer to sections AP-75: Barriers to Affordable Housing and AP-55: Affordable Housing.

The Town of Belmont is fortunate that the majority of its affordable housing units, as identified on the SHI, are preserved in perpetuity (305 out of 388). The remaining 83 units are operated by Mass. DSS and DMH.

No Consortium communities have any properties with expiring use deadlines in FY17.

3. Describe actions planned to reduce lead-based paint hazards:

Newton's Housing Rehabilitation program currently uses CDBG funding to give grants to income-eligible homeowners to remove lead-based paint, asbestos, and other health hazards. The program also offers these homeowners zero-interest deferred payment loans to fix building and safety code violations. This successful program will be continued in FY17.

Many of the Consortium communities cited MassHousing's *Get the Lead Out* program as an option for residents. For all of the Consortium communities, new affordable construction is free from lead paint.

As noted in the Needs Assessment and Market Analysis Chapters of the *FY16-20 Consolidated Plan*, the reported incidence of lead poisoning is low in Newton and surrounding communities. However, over 80% of housing in the City was built before 1980 and therefore a majority of those units are presumed to have lead hazards. As a result, we will continue to make lead paint abatement and the removal of asbestos and other such health hazards a priority in our Housing Rehabilitation program. These statistics on percentage of housing built prior to 1978, when lead paint was banned, are comparable to the statistics for the Consortium as a whole.

These specific lead-based paint hazard prevention and remediation activities are incorporated into the City's housing policies and procedures. The City's Housing Rehabilitation program is marketed to income-eligible homeowners and/or landlords with more than 50% income-eligible tenants to ensure suitable safe living conditions – one of the primary tenets of the CDBG program. In addition, once a rehab application is accepted, the City's Housing Rehabilitation and Construction Manager walks through the entire house with the homeowner, not just the area identified by the applicant as needing repair. In this way, staff is able to identify and remediate all unsafe or unhealthy living conditions. Often the issues identified are mental health related (i.e. hoarding, dementia etc.) as well as general physical disrepair. In these cases, the homeowner can be referred to a social service agency whose staff can appropriately address those other needs as well.

The Massachusetts Department of Public Health's Childhood Lead Poisoning Prevention Program does not consider Bedford to be a high-risk community.

The Town of Concord operates a Small Grants Program that will continue to serve as a financial resource for low- and moderate-income families who need to fund lead paint remediation and other necessary repairs to maintain safe and healthy homes.

All new construction in the Consortium communities is free of lead paint.

4. Describe actions planned to reduce the number of poverty-level families:

One of the priorities of the Housing and Community Development Program is to fund programs and services for poverty-level individuals and families. According to data from the previous decennial Census (in 2000), 2.6 percent of families and 4.3 percent of individuals in Newton were living below poverty level. These percentages represent 811 families and 3,604 individuals. For the most recent five-year ACS estimate (2010-2014), those figures increased to 3.9 percent and 5.6 percent, respectively, which represent approximately 1,215 households and 4,868 individuals. These numbers are similar to the 2013 estimates, as they were 4.5 and 6.5 percent respectively. The 2015 and 2016 federal poverty guidelines are listed in the following table.

Size of Household	POVERTY GUIDELINES (48 Contiguous States and D.C.)	
	2015	2016
1	\$11,770	\$11,880
2	\$15,930	\$16,020
3	\$20,090	\$20,160
4	\$24,250	\$24,300
5	\$28,410	\$28,440
6	\$32,570	\$32,580
7	\$36,730	\$36,730
8	\$40,890	\$40,890
For each additional person, add	\$4,160	\$4,160

Division staff administers the City's Community Development Block Grant (CDBG), HOME Investment Partnerships (HOME), and Emergency Shelter Grant (ESG) programs. The funds from these federal programs are used locally for programs and projects that target and provide the maximum benefit to extremely low- and moderate-income persons. The services provided include rental assistance, housing and relocation stabilization services, and emergency shelter, among other critical support services.

The BNWW CoC works together to ensure the support services are well targeted, especially for chronically homeless persons within the geographic area. In 2014, the CoC developed a Ten-Year Plan to promote community-wide support to end homelessness. The Ten-Year Plan includes strategies that aim to reduce the families living in poverty and without a habitable place to live. These strategies are:

- **Prevention:** Prevention is a key to ending homelessness. Our goal is to reduce the number of individuals and families becoming homeless through the provision of appropriate supportive services and financial assistance.
- **Housing for Homeless and Chronically Homeless Individuals and Families:** Homelessness will not end without increasing the availability of affordable housing. We must reduce the number of homeless and chronically homeless individuals and families by creating opportunities for permanent housing, including supportive housing.

- **Supportive Services:** We recognize that for a significant number of homeless individuals and families, appropriate supportive services are critical to their success in transitioning from homelessness to permanent housing. We must work with providers to improve effectiveness and coordination of supportive services.
- **Engagement of Key Stakeholders:** We must advance the profile and agenda of the CoC among key stakeholders, including homeless and social service organizations throughout the CoC geographic area, in order to ensure and maintain a CoC that is strong, inclusive, and reflects our shared commitment to end homelessness.
- **Public Education and Awareness:** We must inform and educate the public on issues regarding homelessness in the CoC geographic area in order to engage them in our plans to end it.

The public service needs assessment conducted for the *FY16-20 Consolidated Plan* identified the following priorities for families and individuals in poverty.

- To increase the number of transitional (for survivors of DV and their families, as well as unaccompanied homeless youth) and permanent housing units for those at risk for and/or experiencing homelessness;
- Continue to use CDBG, ESG and other financial resources to provide support services for individuals and families that are homeless or are at-risk of homelessness;
- Continue to improve the transition as individual families move from homelessness to permanent housing.

A number of Newton's programs serving poverty-level and low-income households are run by its CDBG Human Service and Emergency Solutions Grant sub-recipients, such as The Second Step, REACH Against Domestic Violence, and the Community Day Center of Waltham. These programs are designed to directly address resident needs.

The Bedford Youth and Family Services envisions its role as a force in fostering a healthy community and improving the quality of life for all Bedford residents by identifying and addressing the social, emotional, and developmental needs of children, youth, adults, and families. The Bedford YFS provides gift cards, fuel assistance, and refers people to other needed resources.

The Belmont Housing Trust works with the Belmont Municipal Light Department and the Council on Aging to publicize the Earned Income Tax Credit program and completes income eligible residents' income taxes for free. The Council on Aging offers elderly homeowners a Property Tax Work-Off Program to reduce their property taxes up to \$1,000 by 'volunteering' a number of hours to the Town based on the current minimum wage. Additionally, a variety of exemptions are available to reduce property tax obligations for certain qualifying taxpayers: elderly persons, blind persons, disabled veterans, surviving spouse or orphaned minor child, widow or orphaned minor of police officer or fire fighter, and extreme hardship. Furthermore,

the Belmont Food Pantry provides food to residents of the Town regardless of their income.

5. Describe actions planned to develop institutional structure:

For many of the Consortium communities, the biggest gap in institutional structure results from limited departmental capacity due to larger workloads, staff turnover, and small numbers of staff.

6. Describe actions planned to enhance coordination between public and private housing and social service agencies:

Please refer to section AP-10: Consultation at the beginning of this plan.

AP-90 Program Specific Requirements - 91.420, 91.220(I)(1,2,4)**HOME Investment Partnership Program (HOME)
Reference 24 CFR 91.220(I)(2)**

1. **Provide a description of the guidelines that will be used for resale or recapture of HOME funds when used for homebuyer activities as required in 92.254.**

Bedford, Belmont, Concord, Lexington, and Needham

These communities are unable to utilize HOME funds for ownership units due to the conflicts between the State's affordable housing deed riders and the HOME Program rule, with respect to the resale and recapture provisions. These communities understand that if a HOME-assisted homeownership project or program is put forward, the recapture/resale provision will have to be submitted to HUD (through the Consortium Administrator) for approval prior to HOME funds being used for such assistance. This guideline has not changed since the submission of the FY16-20 Consolidated Plan.

Brookline

Under recapture provisions, the seller will repay to the Town that portion of the appreciation that reflects the proportion of public subsidy to total homeowner equity. Under resale provisions, the price of the unit will be set at the original purchase price, minus the subsidy, adjusted by changes in the area median income plus compensation for approved capital improvements and, potentially, monitoring fees. The unit will be sold to an income-eligible buyer.

Framingham

The Town of Framingham employs a deed restriction to serve as a recapture mechanism for its HOME-funded down-payment assistance and housing rehabilitation programs. For both types of assistance, if the premises are sold, cease to be the mortgagor's primary residence or there is any change in the title during the term of the promissory note, which commences upon the completion date, or the mortgagor is not in substantial compliance with the promissory note and mortgage, the town will recapture the full HOME loan or the net proceeds, if the net proceeds are less than the full amount of the HOME loan and the Mortgagor's investment.

Natick

The Town of Natick will use the recapture provisions for those housing units that are not intended to be listed on the DHCD Subsidized Housing Inventory (SHI), or do not qualify for the DHCD Local Initiative Program and/or Local Action Units. In these cases, the amount subject to recapture is the amount of the direct subsidy provided to the homeowner, and/or the difference between the fair market value of the property and a reduced sales price attributable to HOME development assistance. The HOME assistance will be recaptured in the full amount of the direct subsidy based on the availability of net proceeds which is defined as the sales price minus superior loan repayment (other than HOME funds) and any closing costs.

For those housing units that are intended to be listed on the DHCD SHI and/or qualify for the DHCD Local Initiative Program or Local Action Unit, the Town of Natick will use the resale provisions to ensure long term affordability. In these cases during the HOME period of affordability, the property must remain affordable to low income homebuyers spending no more than 30 percent of gross income on mortgage payments (PITI) and condo fees; and be sold at a price that provides the owner a fair return on investment. The sale of the property is limited to a credit-worthy eligible purchaser earning between seventy and eighty percent (70-80%) of the Area Median Income for an appropriate size household. During the initial 90 days of marketing, the Town will have a Right of First Refusal to purchase the property.

The basis for a fair return on investment includes the homebuyer's original investment and capital improvements and is dependent on a maximum sales price based on the change in Area Median Income (AMI) over the period of ownership. The maximum sales price is determined by taking the ratio of the original HOME assisted unit sales price over the purchase year AMI, and multiplying this number by the current AMI to get the current base sales price, to which is added closing costs and capital improvements. Capital improvements must be approved by the Town to be considered and are defined as a necessary improvement, not covered by a condo or homeowner fee, that if not done would compromise the structural or functional integrity of the original property. The value of capital improvements at the time of resale will be based on a depreciation schedule. The Town understands that, to the extent that resale price for a HOME-subsidized unit during the HUD period of affordability exceeds what a range of income-eligible buyers can afford, it may be obligated to fund the difference.

Newton

The City of Newton utilizes HOME Program funds for new construction and rehabilitation of homeownership housing, as projects arise. Direct downpayment assistance is provided through local Community Preservation Act funds. Newton uses a resale provision when HOME program funds are used for homebuyer activities, which is incorporated into an affordable housing covenants running with the land. The terms of the resale provision, which apply during the HOME Period of Affordability, are as follows:

Long-Term Affordability. All HOME-assisted units must be sold only to a buyer whose family qualifies as a low-income family earning up to 80 percent of the Boston-Cambridge-Quincy MA-NH Area Median Income (AMI), as published by the U.S. Department of Housing and Urban Development, for the duration of the HOME Period of Affordability. If an eligible buyer is not identified within the allotted resale timeframe the City may exercise a purchase option to ensure that the HOME-assisted unit is resold to a low-income family.

Principal Residence Requirement. The initial purchaser, and all subsequent buyers of a HOME-assisted unit, must use the property as his/her/their principal residence. Newton conducts annual monitoring to ensure this requirement is met.

Resale Price & Fair Return on Investment. If the HOME-assisted unit is sold by the owner during the HOME Period of Affordability, the resale price is calculated as the percentage change of 80 percent of the AMI, as published by HUD, during the term of ownership by the homeowner, plus approved Capital Improvements depreciated over the course of their usual life.

Calculating Fair Return on Investment. Fair Return on Investment is calculated by multiplying the initial purchase price of the HOME-assisted unit by a fraction, the numerator of which is 80 percent of the AMI as published by HUD as of the date of receipt of the owner's notice to sell the affordable unit (Conveyance Notice) and the denominator of which is 80 percent of the AMI as published by HUD as of the date of the initial closing, plus approved Capital Improvements, depreciated over the course of their useful life. The original homeowner's investment (e.g. any downpayment) is included as part of the initial purchase price.

Capital Improvements. Capital Improvements are elements which may add to the value of the unit or prolong its useful life, are of function and quality consistent with comparable affordable housing units, and are owned solely by the owner (not part of any common areas). Maintenance is not considered a capital improvement. The City must approve all capital improvements prior to costs being incurred. These approved capital improvements are subject to depreciation based on the remaining useful life of the element at time of resale. Improvements that are funded by federal, state or local grant programs are not eligible. Some examples of capital improvements include the replacement of non-operational heating or hot water systems, built-in appliances, installation of energy-efficient windows, and insulation.

Continued Affordability to Homebuyers. In accordance with the HOME regulations, Newton is obligated to ensure that the owner of a HOME-assisted unit receives a Fair Return on Investment and that the unit remains affordable to a range of income eligible households upon resale. To maintain continued affordability, the City will target subsequent purchase to appropriately-sized households earning between 70 and 80 percent of the AMI spending no more than 35 percent of gross household income on fixed housing costs (principal, interest, property taxes, condominium fees, if applicable, and insurance), assuming current interest rates offered plus one quarter percent for a 30-year, fixed rate loan and a downpayment of 5 percent. If the resale price exceeds what an eligible household can afford, the City will subsidize the difference with downpayment assistance, mortgage buydown, or other subsidy, as appropriate. To be considered eligible, homebuyers will also be subject to an asset limit of \$75,000. However, any assets up to \$200,000 from the sale of a Newton residence shall be excluded from that determination (but still considered in determination of income eligibility) provided that:

- (a) the sellers must have been no less than 62 years old at the time of that sale; and
- (b) the sale of the residence must be an arms-length transaction.

Waltham

The City of Waltham enforces a recapture provision on all Down Payment assistance loans that it has provided through the WestMetro HOME Consortium. If the premises are sold, cease to be

the Mortgagor's primary residence or there is any change in the title during the term of the Promissory Note, which commences upon the Completion Date, or the Mortgagor is not in substantial compliance with the Promissory Note and Mortgage, the City will recapture the full HOME loan or the net proceeds, if the net proceeds are less than the full amount of the HOME loan and the Mortgagor's investment. The City specifically reserves the right to require full repayment, notwithstanding any deficiency in the amount of the net proceeds, in the event that repayment is triggered by a willful violation by the Borrower of the terms of the Note, or the Mortgage or any applicable HOME regulations. This recapture provision conforms to HUD HOME regulation 24 CFR 92.254 (a)(5)(ii). HUD defines the net proceeds as the sales price minus non-HOME loan repayments and closing costs. If the net proceeds are sufficient to repay both the HOME loan and the Borrower's investment (HUD defines Borrower's investment as the Borrower's down payment and any capital improvement investment), the City must recapture the full HOME loan. Please note, however, that when the net proceeds are insufficient to repay the full HOME assistance, the City will not permit the Borrower to recover more than his/her investment.

The Principal sum may be deferred annually by the City based upon annual review by the Lender of the Borrower's compliance with the terms of this Mortgage, the HOME Program and HOME Project funding agreement and the Promissory Note. The City of Waltham defines capital improvements as a necessary maintenance improvement, not covered by a condominium or homeowners association fee, that if not done would compromise the structural integrity of the property. To be considered a capital improvement, work should meet the following criteria:

- It is not a repair to keep your home in good operating condition.
- It is a new element or replacement of a permanent component of the home, which has reached the end of its useful life.
- It is not part of a common area nor covered by the condominium association fee. This applies to all condo-developed property. (If the condominium or homeowner's association has a special assessment, the City will take into consideration the cost to the homeowner on a case-by-case basis. Additional documentation will be necessary to provide proof of the special assessment.)

Repairs funded by any Federal or State or local Grant Programs are not counted or approved. Improvements such as installation of outdoor decks, additions, garages, and landscaping are luxury improvements and will not be considered as capital improvements.

Watertown

Watertown, on any new projects using HOME funds, through the Watertown Housing Partnership, will use the Massachusetts Department of Community Development and Housing's Capital Improvements Policy and Procedures. Watertown uses a recapture provision which requires the HOME loan recipient to repay the loan, and, in some cases, a pre-payment penalty and a share in the appreciation in the project from the proceeds of the sale.

2. Provide a description of the guidelines for resale or recapture that ensures the affordability of units acquired with HOME funds See 24 CFR 92.254(a)(4):

Bedford, Lexington, and Needham

These communities are unable to utilize HOME funds for ownership units due to the conflicts between the State's affordable housing deed riders and the HOME Program rule, with respect to the resale and recapture provisions. This guideline has not changed since the submission of the FY16-20 Consolidated Plan.

Belmont

Belmont's guidelines for resale or recapture of HOME funds have not changed since the FY16-20 Consolidated Plan was drafted.

Brookline

Under recapture provisions, all properties acquired with HOME funds will have a recorded mortgage stating the affordability period and the process for calculating the recapture amounts.

Under resale provisions, all properties acquired with HOME funds will have a recorded deed restriction stating the affordability period and the process for calculating the resale amount ensuring long term affordability to an income-eligible household that will continue to live in the unit during the affordability period.

Concord

The Town of Concord will use Recapture provisions to ensure the affordability of any units acquired with HOME funds and will seek to recapture the full amount of the HOME funds used in the its purchase if the property is sold within the applicable affordability period. For example, if \$10,000 in HOME funds are needed for the purchase of an affordable unit, the period of affordability will be five years. The property owner may sell the property to any willing buyer at fair market value during the period of affordability. However, if the owner sells the property at any time before the end of that five-year period, the entire amount of the HOME Small Loan funds will be recaptured from the net proceeds of the sale, assuming that the net proceeds are greater than the HOME loan amount. Net Proceeds are defined as the sales price minus superior loan repayment (other than HOME funds) and any closing costs. If the net proceeds from the sale are less than the amount of the HOME loan amount, then the program can only recapture the lesser amount.

Framingham

In Framingham, HOME-assisted units must meet the affordability requirements of five to 20 years beginning after project completion. The affordability requirements apply without regard to the term of any loan or mortgage or the transfer of ownership. They are imposed by deed restrictions approved by HUD.

Natick

The Town of Natick will use the recapture provisions for those housing units that are not intended to be listed on the DHCD Subsidized Housing Inventory (SHI), or do not qualify for the DHCD Local Initiative Program and/or Local Action Units. In these cases, the amount subject to recapture is the amount of the direct subsidy provided to the homeowner, and/or the difference between the fair market value of the property and a reduced sales price attributable to HOME development assistance. The HOME assistance will be recaptured in the full amount of the direct subsidy based on the availability of net proceeds which is defined as the sales price minus superior loan repayment (other than HOME funds) and any closing costs.

For those housing units that are intended to be listed on the DHCD SHI and/or qualify for the DHCD Local Initiative Program or Local Action Unit, the Town of Natick will use the resale provisions to ensure long term affordability. In these cases during the HOME period of affordability, the property must remain affordable to low income homebuyers spending no more than 30 percent of gross income on mortgage payments (PITI) and condo fees; and be sold at a price that provides the owner a fair return on investment. The sale of the property is limited to a credit-worthy eligible purchaser earning between seventy and eighty percent (70-80%) of the Area Median Income for an appropriate size household. During the initial 90 days of marketing, the Town will have a Right of First Refusal to purchase the property.

The basis for a fair return on investment includes the homebuyer's original investment and capital improvements and is dependent on a maximum sales price based on the change in Area Median Income (AMI) over the period of ownership. The maximum sales price is determined by taking the ratio of the original HOME assisted unit sales price over the purchase year AMI, and multiplying this number by the current AMI to get the current base sales price, to which is added closing costs and capital improvements. Capital improvements must be approved by the Town to be considered and are defined as a necessary improvement, not covered by a condo or homeowner fee, that if not done would compromise the structural or functional integrity of the original property. The value of capital improvements at the time of resale will be based on a depreciation schedule. The Town understands that, to the extent that resale price for a HOME-subsidized unit during the HUD period of affordability exceeds what a range of income-eligible buyers can afford, it may be obligated to fund the difference.

Newton

Under resale provisions, all properties acquired through a development subsidy or receiving direct homebuyer assistance with HOME funds will have a recorded deed restriction stating the affordability period and the process for calculating the resale amount to ensure long term

affordability to an income-eligible household during the affordability period. Additionally, any loan issued by the City is secured by a mortgage and promissory note.

Waltham

Under recapture provisions, all properties receiving direct homebuyer assistance and/or rehabilitated with HOME funds will have a recorded mortgage stating the affordability period and the process for calculating the recapture amounts.

Watertown

Under recapture provisions, all properties receiving direct homebuyer assistance with HOME funds will have a recorded mortgage stating the affordability period and the process for calculating the recapture amounts.

Wayland

TBD

- 3. Describe plans for using HOME funds to refinance existing debt secured by multifamily housing that is rehabilitated with HOME funds along with a description of the refinancing guidelines required that will be used under 24 CFR 92.206(b).**

No communities have plans to refinance existing debt secured by properties that have HOME funds in FY17.

**Emergency Solutions Grant (ESG)
Reference 91.220(l)(4)**

- 1. Describe written standards for providing ESG assistance or describe requirements for subrecipients to establish and implement written standards for providing ESG assistance. The minimum requirements are set forth in 24 CFR 576.400.**

Emergency Solutions Grant funding to subrecipients is allocated through a competitive RFP process. This year staff began the process by gathering input from subrecipients as to their programs and funding needs. Additionally, each Fiscal Year the Brookline-Newton-Waltham-Watertown Continuum of Care (CoC) discusses and approves allocation percentages for all services to help homeless individuals and families and those at risk of becoming homeless. These services include Emergency Shelter, Rapid Re-housing, Homelessness Prevention and Street Outreach. The CoC's recommendation strikes a balance between funding existing shelter services and outreach activities and focusing resources on HUD's priorities of homelessness prevention and rapid re-housing. The principles included in the CoC's "Ten-Year Plan to End Homelessness" further guides this allocation recommendation.

Once we receive our annual ESG allocation from HUD, City staff develops and issues an RFP for local non-profit agencies to request funding in these four areas. The RFP requires the respondent's to indicate how their programs will assist homeless individuals and families or those at risk of homelessness in each of these areas, as well as how the programs will help clients meet the 8 Benchmarks for Social Mobility. The City adopted these Benchmarks based on the Brookings Institute "Benchmarks for Success" from the Social Genome Model to promote economic mobility and stability across the lifespan for individuals and families.

- 2. Has the Continuum of Care for the jurisdiction's area established a centralized or coordinated assessment system that meets HUD requirements? If yes, describe the centralized or coordinated assessment system.**

The Brookline-Newton-Waltham-Watertown Continuum of Care (BNWW CoC) is finalizing its centralized or coordinated assessment system. The system that will be adopted by the BNWW CoC providers is modeled in part after the system used by the Boston Continuum of Care and the Massachusetts Balance of State Continuum of Care. Since 2015, the CoC has reached a few milestones, including developing and testing a Coordinated Entry Vulnerability Assessment Tool, reviewing data sharing agreements, and considering best practices for release of information authorization forms and the use of unique identifiers. The BNWW CoC intends to do beta testing on its proposed process immediately, and providers will begin implementing the coordinated assessment process in July 2016 with the assistance of The Cloudburst Group, HUD's technical assistance providers. Initially, providers will append the coordinated assessment forms to the existing intake process, which will be migrated into a centralized digital database for real-time data sharing. The BNWW CoC is also exploring the creation of a

coordinated exit system as well to track placements and determine “success rate” for those individuals who have exited homelessness as a result of services received.

3. Identify the process for making sub-awards and describe how the ESG allocation available to private nonprofit organizations (including community and faith-based organizations).

ESG funding is allocated through a competitive RFP process. City staff develops and issues an RFP based on input from the Brookline-Newton-Waltham-Watertown Continuum of Care (CoC). Non-profit agencies that assist the homeless or those at risk of homelessness can request funding for their programs. Staff initially reviews each response to the RFP and considers eligibility under the regulations of the ESG program and feasibility of implementation. Additionally staff uses data about proposed outcomes and past performance, when available, to determine whether to recommend funding for a particular program. Per our Citizen Participation Plan, staff recommendations are forwarded to the Human Service Advisory Committee for its input and then to the Planning and Development for a public hearing. The Mayor approves the final allocation amounts.

4. If the jurisdiction is unable to meet the homeless participation requirement in 24 CFR 576.405(a), the jurisdiction must specify its plan for reaching out to and consulting with homeless or formerly homeless individuals in considering policies and funding decisions regarding facilities and services funded under ESG.

To the extent possible, City staff reaches out to residents who have experienced homelessness. Each year, we coordinate the Point-In-Time Count for the Brookline-Newton-Waltham-Watertown Continuum of Care. In support of this effort, City staff develops a survey to determine demographic information about this vulnerable population as well as specific reasons for why someone is homeless and/or, whenever possible, what services may be needed to improve his/her situation in the future.

In addition, the CoC, comprised of staff from the four municipalities as well as from local non-profit agencies that serve the homeless population, proposes allocations for each category of services: Shelter services; Rapid Re-housing; Homelessness Prevention and; Outreach. The agency staff has direct contact on a daily basis with potential beneficiaries and their work informs the CoC’s decisions.

5. Describe performance standards for evaluating ESG.

Prior to the review and release of the RFP, City staff evaluates the uses and outcomes of ESG – funded projects. This is done in consultation with service providers, as well as a review of performance reports that are submitted during the grant year. The CoC will be presented with this information in order to provide input about funding priorities for each ESG component.

Additionally, Division staff has contacted DHCD's HMIS training specialist to conduct free training to new users or users who require a refresher. This will ensure that ESG service providers learn how to navigate Efforts to Outcomes (ETO) and input client intake/exit information.

AP-10: Consultation for the City of Newton and the WestMetro HOME Consortium

Agency/Group/Organization Type	Type of Organization	Type of Organization (if serving multiple purposes)	What Section of the Plan was addressed by consultation?	How was the organization consulted?	What are the anticipated outcomes of the consultation or areas for improved coordination?
NEWTON					
Newton Housing Authority	Public Housing Authority	N/A	Public Housing Needs	The Newton Housing Authority (NHA) helped complete sections of the FY16-20 Consolidated Plan. Division staff reviewed NHA's five year plan is consistent with the Consolidated Plan on an annual basis.	This collaboration ensures that Newton is helping create as many affordable housing opportunities as possible.
Citizens for Affordable Housing in Newton Development Organization	Services-homeless	Neighborhood Organization	Housing Need Assessment	The Director of CAN-DO has attended several public meetings to discuss the different sections of the Consolidated Plan	
Citizens' Housing and Planning Association	Housing	Neighborhood Organization	Housing Need Assessment	The staff at CHAPA has attended public meetings to discuss the different sections of the Consolidated Plan	
Newton Advisory Committees	Other	N/A	All Needs Assessments; Strategic Plan; Annual Action Plan	The committees meet regularly to provide important input on the needs assessment, priorities and overall strategy of the Consolidated Plan.	Guides staff and local official on the housing, community and economic development efforts in Newton.
Massachusetts Department of Housing and Community Development	Housing	N/A	Housing Need Assessment	The staff at DHCD was involved in reviewing the housing projects/plans for the next five years.	This collaboration ensures that Newton is helping create as many affordable housing opportunities as possible.
BEDFORD					
Bedford Housing Partnership	Housing	N/A	Housing Need Assessment	The plan was reviewed and voted by the Bedford Housing Partnership	The anticipated outcomes of the consultation are improved coordination and the inclusion of the organization's input in the Action Plan.
BELMONT					
Belmont Housing Authority	Public Housing Authority	N/A	Public Housing Needs	The Director of the Housing Authority was contacted directly. A member of the Housing Authority sits on the Housing Trust and attends all of their meetings	The anticipated outcomes of the consultation include continued outreach by all of those involved in housing and the inclusion of the Housing Authority's input in the Plans.
Belmont Housing Trust	Housing	N/A	Housing Need Assessment Market Analysis	The Trust was involved in reviewing the draft Housing Production Plan. Staff attends meetings and is in	The anticipated outcomes of the consultation include continued coordination between those involved with
Belmont Health Department	Health Agency	N/A	Housing Need Assessment Market Analysis	The Social Work Coordinator and Veteran Services Agent were contacted directly.	The anticipated outcomes of the consultation include continued coordination between those involved with
Council on Aging	Services-Elderly Persons	N/A	Housing Need Assessment Market Analysis	The Director and the Social Work Coordinator were contacted directly.	The anticipated outcomes of the consultation include continued coordination between those involved with
BROOKLINE					
Brookline Housing Advisory Board	Civic Leaders	Housing	Housing Need Assessment/FY17 Annual Action Plan	The Brookline Housing Advisory Board held a public meeting to review and comment upon the FY17 Annual Action Plan	The anticipated outcomes of the consultation are prioritizing HOME funds.
Brookline Housing Authority	Public Housing Authority	Housing	Public Housing Needs	The BHA was interviewed about public housing needs as well as capital needs for state-owned public housing in FY17 and beyond.	Information helps inform the Town of BHA needs as we coordinate housing resources for new projects as well as preservation of affordable units.
Brookline Health Department	Health Agency	N/A	Housing Need Assessment	The Health Department works with persons with disabilities, homeless, and persons with substance abuse and gave feedback regarding the housing needs assessment	The anticipated outcomes of the consultation are improved coordination and the inclusion of the organization's input in the Consolidated Plan and Action Plan.
Brookline Diversity, Inclusion, and Community Relations Department	Service-Fair Housing	N/A	Housing Need Assessment	The Brookline Diversity, Inclusion, and Community Relations Dept. works on issues of fair housing, diversity, and inclusion	
Brookline Community Mental Health Center	Services-homeless	Services-Victims of Domestic Violence	Homelessness Strategy	The BCMHC provides homelessness prevention services and was interviewed for the Needs Assessment. BCMHC provides on-going case management to those experiencing housing problems and homelessness in the Town.	
Brookline Council on Aging	Services-Elderly Persons	N/A	Housing Need Assessment	The Council on Aging provides a wide variety of services to seniors and informs the Town on the housing needs of Brookline seniors. The Council provides case management to seniors experiencing housing problems.	
Center Communities of Brookline	Housing	Services-Elderly Persons	Housing Need Assessment	This agency provides senior housing and was interviewed regarding housing needs of seniors	
Pine Street Inn	Housing	Services-homeless	Housing Need Assessment	This agency provides housing and services to homeless individuals within the community and was interviewed for the Housing Needs Assessment	
Brookline Community Foundation	Foundation	Civic Leaders	Housing Need Assessment	The agency was interviewed to provide information on the Housing Needs Assessment and provides general information on housing needs to the community.	
CONCORD					
Concord Housing Authority	Public Housing Authority	N/A	Public Housing Needs	The CHA was contacted directly to discuss their two projects to rehabilitate and expand their inventory of accessible affordable units.	The anticipated outcomes of the consultation are improved coordination and the inclusion of the organization's input in the Action Plan.
FRAMINGHAM					
Framingham Housing Authority	Public Housing Authority	Public Housing Authority	Public Housing Needs	Consultation	The anticipated outcomes of the consultation are improved coordination and the inclusion of the organization's input in the Action Plan.
South Middlesex Opportunity Council SMOC	Housing	Services-homeless	Housing Need Assessment	Consultation	
Framingham Planning Office	Other government - Local	N/A	Housing Need Assessment	Consultation	
Framingham Veteran's Office	Other government - Local	Services-homeless	Homelessness Needs - Veterans	Consultation	
Framingham Council on Aging	Services-Elderly Persons	N/A	Housing Need Assessment	Consultation	
Framingham Health Department	Other government - Local	N/A	Omitted	Consultation	
Framingham Assessing Department	Other government - Local	N/A	Housing Need Assessment	Consultation	
Fair Housing Commission	Other government - Local	Other government - Local	Housing Need Assessment	Consultation	
Framingham Disability Commission	Other government - Local	Services-Persons with Disabilities	Housing Need Assessment	Consultation	
Balance State Continuum of Care	Regional organization	Services-homeless	Homelessness Strategy	Consultation	
Wayside Community Programs	Housing	Services-Children	Housing Need Assessment	Consultation	
Advocates	Services-Persons with Disabilities	N/A	Housing Need Assessment	Consultation	
MetroWest Legal Services	Other	Services-homeless	Homelessness Strategy	Consultation	
Metro West Center for Independent Living	Services-Persons with Disabilities	N/A	Housing Need Assessment	Consultation	
Bay Path Elder Services	Services-Elderly Persons	Services-Persons with Disabilities	Housing Need Assessment	Consultation	

#133-16

LEXINGTON					
Lexington Housing Partnership	Housing	N/A	Annual goals	All HOME projects are reviewed by the Lexington Housing Partnership	The anticipated outcomes of the consultation are improved coordination and the inclusion of the organization's input in the Action Plan.
NATICK					
Council on Aging	Services-Elderly Persons	N/A	Housing Needs	Interview	The anticipated outcomes of the consultation are improved coordination and the inclusion of the organization's input in the Action Plan.
Natick Affordable Housing Trust	Other government - Local	N/A	Housing Needs	Interview	
Natick Housing Authority	Public Housing Authority	N/A	Housing Needs	Interview - Meetings	
NEEDHAM					
Needham Board of Selectmen	Other government - Local	N/A	Housing Strategy	Held a meeting on October 27, 2015 to discuss the Town's Housing Strategy.	Better coordination in the implementation of various elements of the FY16-20 Consolidated Plan's Strategic Plan chapter and the Annual Action Plan.
SUDBURY					
Sudbury Housing Trust	Other government - Local	Service-Fair Housing	Housing Need Assessment	Consultation/Committee Meeting	Improve coordination between housing stakeholders in Town and the Trust and inclusion of the organization's input in the Annual Action Plan
WALTHAM					
Middlesex Human Services Agency	Services-homeless	Services-homeless	Homeless Needs - Chronically homeless	Consultation	Provide grant funds for shelter & reduce homeless population
Waltham Police Department	Civic Leaders	Services-Children	Homelessness Needs - Unaccompanied youth	Monthly Homeless Coalition meetings, Youth Liaison between PHA and Police Department	Collaborative effort to engage youth with funding for student staff (Bentley & Bradeis University students) at Housing Authority community centers.
The Greater Waltham Association of Retarded Citizens	Services-Persons with Disabilities	Service-Fair Housing	Non-Homeless Special Needs	Consultation	Ensure quality housing for persons with disabilities
The Partnership for Youth	Services-Education	Services-Children	Non-Homeless Special Needs	Consultation	Increased funding for language education for non English speaking elementary students
REACH	Services-Victims of Domestic Violence	Services-Education	Non-Homeless Special Needs	Consultation	Increase opportunities for parent education programs
Boys and Girls Club	Services-Children	Neighborhood Organization	Homelessness Needs- Unaccompanied Youth	Consultation	Extend outreach to older teens and youth.
Waltham Housing Authority	Public Housing Authority	Housing	Public Housing Needs	Consultation	Affordable rental housing for seniors
Committee on Downtown Revitalization	Business Leaders	Neighborhood Organization	Market Analysis - Economic Development Needs	Consultation	Encourage economic approach to development
Community Day Center of Waltham	Services-homeless	N/A	Homeless Needs - Chronically homeless	Consultation	Omitted
Waltham Committee Inc.	Housing	Services-Persons with Disabilities	Non-Homeless Special Needs - Housing for Persons with Disabilities	Consultation	Increased housing for persons with disabilities
WATERTOWN					
Watertown Housing Partnership	Other government - Local	N/A	Housing Need Assessment	Housing Partnership reviewed Watertown's section of the FY 2017 Annual Action Plan at its January 2016 meeting.	Anticipated outcomes of the consultation are inclusion of the Town Committee's input into the FY 2017 Annual Action Plan.
Watertown Housing Authority	Public Housing Authority	N/A	Other (Please specify)	Watertown Housing Authority was consulted several times on the FY 2017 Annual Action Plan	Anticipated outcomes of the consultation are inclusion of the Housing Authority's input into the FY 2017 Annual Action Plan
Religious Organizations, Social Service Providers and Community Groups	Social Service Providers	Various Services	Other (Please specify)	Mailed a notice of the Watertown Housing Partnership's January meeting to discuss the FY 2017 Annual Action Plan	No comments received
WAYLAND					
Wayland Housing Authority	Public Housing Authority	Service-Fair Housing	Housing Need Assessment	Consultation	Anticipated outcomes of the consultation are inclusion of the Housing Authority's input into the 2017 Annual Action Plan
Wayland Housing Partnership	Other government - Local	N/A	Housing Need Assessment	Consultation	Anticipated outcomes of the consultation are inclusion of the Housing Authority's input into the 2017 Annual Action Plan
Wayland Housing Trust	Other government - Local	Housing	Public Housing Needs	Consultation	Anticipated outcomes of the consultation are inclusion of the Housing Authority's input into the 2017 Annual Action Plan
Wayland Real Asset Planning Committee	Other government - Local	Housing/Real Estate	Housing Needs Assessment	Consultation	Anticipated outcomes of the consultation are inclusion of the Housing Authority's input into the 2017 Annual Action Plan

AP-10: Other Plans Considered by the City of Newton and WestMetro HOME Consortium

#155-16

Name of Plan	Lead Organization	How do the goals of your Strategic Plan overlap with the goals of each plan?
Ten Year Plan to End Homelessness (updated 2014)	City of Newton on behalf of the Brookline-Newton-Waltham-Watertown Continuum of Care	The Strategic Plan adopts many of the priorities and strategies detailed in this plan
Analysis of Impediments to Fair Housing (updated July 2014)	City of Newton	The Strategic Plan works to address some of the impediments to fair housing identified in the AI
MAPC Metro Boston 2030 Population and Housing Demand Projections and more recent Housing Data Portal	Metropolitan Area Planning Council	Division staff relied on Newton and regional data and projections provided by the MAPC in this document. Division staff adopted the Stronger Region scenario, recommended by the MAPC to plan for the needs that will be facing Newton and the region
FY16 Annual Action Plan	City of Newton	Key document to inform the City's community development and housing goals throughout FY16
FY16-20 Consolidated Plan	City of Newton	Key document to inform the City's community development and housing goals through 2020 and basis for the goals included in the FY17 AAP
2007 Comprehensive Plan	City of Newton	The Comprehensive Plan focuses on strengthening and enhancing Newton as a liveable community and that goal overlaps with Division staff's efforts to do the same for LMI people in Newton
Belmont's Draft Housing Production Plan	Town of Belmont	
Natick 360	Town of Natick	
Natick Housing Production Plan 2016	Natick Affordable Housing Trust	
Previous local housing plans	Needham Planning and Community Development Dept.	
Local Housing Guidelines	Needham Planning and Community Development Dept.	
Other HOME reports	Needham Planning and Community Development Dept.	
Open Space and Recreation Plan	City of Waltham	
Analysis of Impediments	City of Waltham	
Emergency Case Plan	DHCD	
Public Housing Authority Plan (2012)	Waltham Housing Auth	
Watertown Comprehensive Plan (Adopted April 2015)	Watertown Department of Community Development and Planning	
Analysis of Impediments to Fair Housing Plan for Fiscal Year 2013	Watertown Department of Community Development and Planning	

Watertown Housing Production Plan (Adopted January 2014)	Metropolitan Area Planning Council and Watertown Department of Community Development and Planning
Annual Action Plan (Fiscal Years 2013- 2016)	Watertown Department of Community Development and Planning
Brookline Analysis of Impediments to Fair Housing Choice	Town of Brookline
"Understanding Brookline: A Report on Poverty"	Brookline Community Foundation
Framingham Housing Plan	Community Economic Development Department
Framingham Analysis of Impediments	Community Economic Development Department
Downtown Framingham TOD	N/A
Elder Services 2014-2017 Area Plan	Bay Path Elder Services
Framingham Open Space Plan	Community Economic Development Department
South East Framingham Study Area	Framingham Planning Board Department
Town of Wayland Master Plan 2004 (updated 2011)	Wayland Planning Board; Board of Selectment; Wayland Economic Development Committee
Town of Wayland Housing Plan 2010 (updated 2015)	Wayland Planning Board; Board of Selectment; Wayland Economic Development Committee

#133-16

The Strategic Plan chapter for the FY16-20 Consolidated Plan, in addition to the FY17 Annual Action Plan, adopts many of the priorities and strategies detailed in these plans.

AP-12: Citizen Participation Outreach for the City of Newton and the WestMetro HOME Consortium

Mode of Outreach	Target of Outreach	Summary of response/attendance	Summary of comments received	Summary of comments not accepted	#133-16 Other from Mode
NEWTON					
Public Meeting	General	3	Significant barrier to affordable housing is the high land values in Newton. Would like to see a report/presentation on housing-related spending and accomplishments for the year	N/A	Newton Housing Partnership
Public Meeting	General	8	inclusion of a paragraph about the FHC and the "Fair Housing Policy statement"; education/training sessions on "disparate impact" for City Councilors; additional educational community meetings; making fair housing a priority; education for community, landlords, & CDBG service providers	N/A	Fair Housing Committee
Public Meeting	General	14	Needs for additional resources; needs for permanent supportive housing development; needs for homeless veterans' emergency shelter; need for implementation of coordinated entry system; discussion of Engine 6 voluntary compliance agreement; need for additional performance measures specifically pertaining to homelessness	N/A	Homelessness; Brookline-Newton-Waltham-Watertown Continuum of Care
Public Meeting	General	5	Discussion regarding FY17 Human Service program awards.	N/A	Human Services Advisory Committee
Public Meeting	General	16	Discussion of proposed FY17 pedestrian safety and traffic improvements project	N/A	Newton Corner Target Neighborhood
Public Hearing	General	TBD	Discussion of draft FY17 Annual Action Plan	N/A	P&D Review
Public Meeting	General	11	Selection of an FY17 access project and discussion of upcoming projects to be finalized and set up later in FY17	N/A	Commission on Disability
BEDFORD					
Public Hearing	Non-targeted/broad community	Bedford Housing Partnership members attended	Approval of plan	N/A	N/A
BELMONT					
Public Meeting	Non-targeted/broad community	12 people attended the meeting including representatives from the Planning Board	Discussed the need for more small-scale housing; affordable housing; mixed-use in appropriate locations; how to reduce associated barriers	N/A	N/A
Public Meeting	Non-targeted/broad community	Meeting with the Belmont Housing	Discussed various goals, objectives and strategies.	N/A	N/A
Other	Other	A series of working meetings with the Board of Selectmen, Planning Board and Belmont Housing Trust.	Reviewed the draft Housing Production Plan and discussed goals, objectives and strategies.	N/A	N/A
BROOKLINE					
Public Meeting	Non-targeted/broad community	Meeting of the Housing Advisory Board	Regularly scheduled meeting included discussion of looking for a new rental development project.	N/A	N/A
CONCORD					
Meeting	Non-targeted/broad community	Discussion with the Concord Housing Authority	None received.	N/A	N/A
FRAMINGHAM					
Public Meeting	Non-targeted/broad community	Meeting held on September 22, which had 9 attendees representing various members of the community. Four community development committee members in attendance.	Attendees provided their input on the CAPER.	N/A	N/A
Needs Assessment	Nonprofit agency providers/residents	Meeting held on December 1, 2015 which had 20 attendees representing various agencies and their representatives. Four community development committee members in attendance.	Need for new and diverse amenities in the community, such as more open space, youth oriented facilities and programming and economic development initiatives that support downtown businesses.	N/A	N/A
Committee Meeting	Committee members/broad community	Meeting held on January 19 by committee members to vote in officers and set a 2016 agenda	Members set the 2016 agenda and elected officers.	N/A	N/A

Public Hearing	Non-targeted/broad community	Hearing held on January 26 to assess proposals submitted for the FY17 public services funding cycle	The community development committee met to assess applications and make decisions about grantees. Committee members asked questions about applications to grantees.	N/A	#133-16 N/A
Internet Outreach	Non-targeted/broad community	Encouraged residents and individuals of community based organizations to attend public hearings and to remain engaged in town initiatives by signing up to receive alerts through the "Notify Me" function of the Framingham website.	Residents accepted directions to town's website and sign up for alerts.	N/A	N/A
LEXINGTON					
No information provided.					
NATICK					
No information provided.					
NEEDHAM					
Public meeting	Non-targeted/broad community	The Planning Board held a public meeting on September 1, 2015 to discuss the Town's Housing Strategy.	Comments involved the support of the redevelopment of the NHA's Linden-Chambers project, a Municipal Affordable Housing Trust, new zoning to further encourage multi-family housing and mixed-uses, among other actions.	N/A	N/A
Public meeting	Non-targeted/broad community	The Planning Board and Board of Selectmen held a joint public meeting to discuss the Town's Housing Strategy on October 27, 2015.	Comments included the redevelopment of the NHA's Linden-Chambers project, encouraging new housing in the Town Center and Needham Crossing, greater emphasis on green building, 40R districts, starter housing, etc.	N/A	N/A
SUDBURY					
Public Meeting	Non-targeted/broad community	Open Meeting of Sudbury Housing Trust. Trustees in attendance only	None received.	N/A	N/A
WALTHAM					
Internet Outreach	Non-targeted/broad community	Community Vision Survey, 45 online responses between submission of 5 year plan (May 2015) and January 2016	Comments discussed need for Public Housing Upgrades, youth and elderly programming	N/A	Paper surveys also accepted
Public Meeting	Non-targeted/broad community	Meeting held on January 11, 2016; attended by approximately 15 people; majority of attendees represented funded agencies	Need for elderly programming, also a need for ADA upgrades to multiple facilities	N/A	N/A
WATERTOWN					
Public Meeting	Non-targeted/broad community	N/A	Meeting of the Watertown Housing Partnership	N/A	N/A
WAYLAND					
Public Meeting	Non-targeted/broad community	Attended by approximately 25 people from the following Boards: Wayland Housing Authority; Wayland Housing Partnership; Wayland Housing Trust; Wayland Planning Board	At this joint meeting it was agreed that the Town would form three working groups to explore how we can move the affordable housing agenda forward. Group 1: Defining a shared vision and priorities for affordable housing. Group 2: Monitoring and preserving existing affordable housing. Group 3: Assessing whether there is need for new zoning or overlay districts as outlined in the master plan or other alternatives.	N/A	N/A

AP-15: Anticipated Resources for City of Newton & WestMetro HOME Consortium for FY17

Source	Source	Uses of Funds	Expected Amount Available Year 1				Narrative Description
CDBG	public - federal	Acquisition, Admin & Planning, Economic Development, Housing, Public Improvements, Public Services	Annual allocation (\$):	\$	1,742,529.00	Please see word document for narrative.	
			Program Income (\$):	\$	125,000.00		
			Prior Year Resources (\$):				
			Total (\$):	\$	1,867,529.00		
HOME	public - federal	Acquisition, Homebuyer Assistance, Homeowner Rehab, Multifamily rental new construction, Multifamily rental rehab, New construction for ownership, TBRA	Annual allocation (\$):	\$	1,137,827.00	Please see word document for narrative.	
			Program Income (\$):				
			Prior Year Resources (\$):				
			Total (\$):	\$	1,137,827.00		
ESG	public - federal	Conversion and rehab for transitional housing, Financial assistance, Overnight shelter, Rapid re-housing (rental assistance), Rental assistance, Services, Transitional housing	Annual allocation (\$):	\$	159,211.00	Please see word document for narrative.	
			Program Income (\$):				
			Prior Year Resources (\$):				
			Total (\$):	\$	159,211.00		
Other (specify)	public-local	Housing, Homebuyer Assistance, Multifamily rental new construction, Multifamily rental rehab, New construction for ownership	Annual allocation (\$):	TBD		Expected allocation of new Community Preservation Act funds for open space, community housing and historic preservation for FY16. 10% of allocation reserved for community housing. Please see Annual Action Plan text for narrative.	
			Program Income (\$):				
			Prior Year Resources (\$):				
			Total (\$):	\$	-		
Continuum of Care	public-federal	Admin and Planning, Housing, Financial assistance, overnight shelter, transitional housing	Annual allocation (\$):	TBD		CoC Funding includes a match and leverage requirement for each grantee. Please see Annual Action Plan text for narrative.	
			Program Income (\$):				
			Prior Year Resources (\$):				
			Total (\$):	\$	-		

AP-20: Annual Goals for City of Newton & WestMetro HOME Consortium for FY17

Name of Goal	Description of Goal	Category of Goal	Geographic Area (if applicable)	Start Fiscal Year	End Fiscal Year	Outcome	Objective	Goal Outcome Indicator (GOI)	GOI Quantity	GOI Unit of Measurement	Priority Needs Addressed (listed in sheet SP-25 of the FY16-20 Com Plan)
NEWTON											
Production of New Affordable Units	Increase production of new affordable units and visible and accessible units through incentives, flexible funding, and inclusionary zoning.	Affordable housing	N/A - Citywide	2017	2018	Affordability	Provide decent affordable housing	Rental units constructed	10	Household housing unit	Affordable housing near amenities, additional accessible rental units and visible housing, inclusionary zoning incentives, flexible funding for affordable housing
								Homeowner housing added	0	Household housing unit	
Housing Rehab	Continue the housing rehab program for income-eligible residents, including improvements for accessibility and safety, especially for seniors to encourage aging in place	Affordable housing	N/A - Citywide	2017	2018	Availability/accessibility	Provide decent affordable housing	Homeowner housing rehabilitated	5	Household housing unit	Housing rehab; aging in place
Supportive Services (ESG + CDBG)	Provide supportive services for individuals and families that are homeless or at-risk for homelessness	Homeless	N/A - Citywide	2017	2018	Availability/accessibility	Creates suitable living environments	Rental units rehabilitated	5	Household housing unit	Supportive services
Improve Transition to Permanent Housing	Improve the transition as families and individuals move from homelessness into permanent housing through a pilot TBRA program	Homeless	N/A - Citywide	2017	2018	Affordability	Provide decent affordable housing	Tenant-based rental assistance / rapid rehousing	3	Households Assisted	Transitional and permanent housing units; improve transition to permanent housing
Fair Housing	Meet the need for more fair housing education, enforcement, and obligations.	Other - Please Specify	N/A - Citywide	2017	2018	Availability/accessibility	Provide decent affordable housing	Other-Educational events	2	Other-Educational events held	Fair housing
Human Services - Aging in Place	Provide financial support for organizations and agencies serving individuals that fall under key areas of need: including children, teens, families, and persons with disabilities. This number excludes seniors served through Human Service projects.	Non-homeless special needs	N/A - Citywide	2017	2018	Availability/accessibility	Create suitable living environments	Public service activities other than Low/Moderate Income Housing benefit	1,513	Persons assisted	Human services
								Public service activities other than Low/Moderate Income Housing benefit	1,266	Persons assisted	Aging in place
Neighborhoods Improvements	Continue to meet the need for improvements to public facilities, infrastructure, and open space that best benefit low- and moderate-income residents in and around eligible census block groups in the Newton Corner target neighborhood	Non-housing community development	Based on area-benefit eligible block groups: Citywide	2017	2018	Availability/accessibility	Create suitable living environments	Public Facility or Infrastructure Activities other than Low/Moderate Income Housing (LMH) Benefit	1,560	Persons Assisted	Neighborhood improvements
								Public Facility or Infrastructure Activities other than Low/Moderate Income Housing (LMH) Benefit	3,394	Persons Assisted	Architectural Access
BEDFORD											
Rental housing	Funds will be used to assist the creation of rental housing or to assist the rehabilitation of rental housing	Affordable housing	Bedford	2017	2018	Affordability	Provide decent affordable housing	Rental units constructed	1	Household housing unit	Rental Housing
BELMONT											
Rehab public housing	Funds will be used to install an elevator to make units accessible	Affordable housing	Belmont	2017	2018	Availability/accessibility	Creates suitable living environments	Rental units rehabilitated	51	Household housing unit	Public housing; rental housing
Elderly supportive services	Funds will be provided to renovate housing so that elderly can age in place.	Affordable housing	Belmont	2017	2018	Availability/accessibility	Creates suitable living environments	Rental units rehabilitated	2	Household housing unit	Accessibility
Rehab public housing	Funds will be used to assess the possibility of more housing development to offset costs of rehabbing existing units	Public housing	Belmont	2017	2018	Affordability	Provide decent affordable housing	Rental units constructed	10	Household housing unit	Public housing; rental housing
First Time Homebuyer Program	Funds will be used by first time homeowners to aid in purchasing a home.	Affordable housing	Belmont	2017	2018	Affordability	Provide decent affordable housing	Homeowner housing added	3	Household housing unit	Providing housing for small families, preserve affordable housing
BROOKLINE											

Name of Goal	Description of Goal	Category of Goal	Geographic Area (if applicable)	Start Fiscal Year	End Fiscal Year	Outcome	Objective	Goal Outcome Indicator (GOI)	GOI Quantity	GOI Unit of Measurement	Priority Needs Addressed (listed in sheet SP-25 of the FY16-20 Con Plan)
New Rental Housing	Funds will be used to develop new rental housing opportunities for extremely low-, low-, and moderate-income households. This will include identifying new opportunities to construct additional affordable rental units.	Affordable housing	Brookline	2017	2018	Affordability	Provide decent affordable housing	Rental units constructed	25	Household housing unit	Rental Housing
Preservation of Rental Housing	Funds will be used to preserve affordable rental housing for extremely low-, low-, and moderate-income households. This will include the close out of the Beals Street project as well as pursuing several new opportunities to preserve existing rental units as affordable.	Affordable housing	Brookline	2017	2018	Affordability	Provide decent affordable housing	Rental units rehabilitated	31	Household housing unit	Rental Housing
Inclusionary Units/ 40B units - rental	Market-rate rental housing developments will include 15% affordable units (or in the case of 40B 20-25% affordable units) for households serving less than 80% of AMI	Affordable housing	Brookline	2017	2018	Affordability	Provide decent affordable housing	Rental units constructed	75	Household housing unit	Rental Housing
45 Marion Street	40B Development of 64-unit rental building containing 13 units serving households earning less than 50% AMI	Affordable housing	Brookline	2017	2018	Affordability	Provide decent affordable housing	Rental units constructed	13	Household housing unit	Rental Housing
Homebuyer Assistance Program	Funds will be used to write down costs of condo units in order to make them affordable	Affordable housing	Brookline	2017	2018	Affordability	Provide decent affordable housing	Homeowner housing added	0	Household housing unit	Ownership housing
CONCORD											
Creating new Senior and Accessible Units	Funds will be used to assist the creation of rental housing for senior and disabled individuals	Public Housing	Concord	2017	2018	Availability/accessibility	Provide decent affordable housing	Rental units constructed	4	Household housing unit	Creating New Affordable Units in close proximity to Town Center
FRAMINGHAM											
Housing Development	Promote the development of new affordable units.	Affordable housing; public housing	Framingham	2017	2018	Affordability	Provide decent affordable housing	Rental units constructed	1-4	Household housing unit	Housing development
Public Housing Improvements	Support Framingham Housing Authority projects whenever possible	Affordable housing; public housing	Framingham	2017	2018	Availability/accessibility	Create suitable living environments	Rental units rehabilitated	5	Household housing unit	Housing rehab
Tenant-based Assistance	Provide funding support to organizations that deliver rental assistance to local residents	Affordable housing	Framingham	2017	2018	Affordability	Provide decent affordable housing	Tenant-based rental assistance / rapid rehousing	21	Households Assisted	Tenant-based rental assistance
LEXINGTON											
Rental housing	Funds will be used to assist the creation of rental housing or to assist the rehabilitation of rental housing	Affordable housing	Lexington	2017	2018	Affordability	Provide decent affordable housing	Rental units constructed	1	Household housing unit	Rental Housing
NATICK											
Rental Assistance	Funds will be used to assist in alleviating rental demands of persons earning at or below 80% AMI.	Affordable housing	Natick	2017	2018	Affordability	Provide decent affordable housing	Tenant-based rental assistance / rapid rehousing	40	Households Assisted	Rental Housing
NEEDHAM											
No FY17 goals.											
SUBURBY											
No FY17 goals. All funds in this year will be used to repay Natick for funds borrowed to finance the Coolidge at Sudbury project.											
WALTHAM											
Affordable Housing/Rental Assistance	Funds will be used for the TBRA Security Deposit program to provide first month's rent and security deposit payment to income-eligible households	Affordable Housing	Waltham	2017	2018	Affordability	Provide decent affordable housing	Tenant-based rental assistance / rapid rehousing	95	Households Assisted	Rental Housing
WATERTOWN											
Create affordable housing	Create additional affordable housing units	Affordable Housing	Watertown	2017	2018	Affordability	Provide decent affordable housing	Rental units constructed	5-10	Household housing unit	Rental Housing
Create additional affordable housing (families)	Create additional affordable housing with a minimum of 3 bedrooms, suitable for families	Affordable housing	Watertown	2017	2018	Affordability	Provide decent affordable housing	Rental units constructed	5-10	Household housing unit	Rental Housing
Create affordable housing suitable for the elderly	Create additional affordable housing suitable for the elderly	Non-homeless special needs	Watertown	2017	2018	Affordability	Provide decent affordable housing	Rental units constructed	5-10	Household housing unit	Rental Housing

Name of Goal	Description of Goal	Category of Goal	Geographic Area (if applicable)	Start Fiscal Year	End Fiscal Year	Outcome	Objective	Goal Outcome Indicator (GOI)	GOI Quantity	GOI Unit of Measurement	Priority Needs Addressed (listed in sheet SP-25 of the FY16-20 Con Plan)
Create affordable housing suitable for those with disabilities	Create additional housing suitable for those with disabilities	Non-homeless special needs	Watertown	2017	2018	Availability/accessibility	Create suitable living environments	Rental units constructed	5-10	Household housing unit	Rental Housing
WAYLAND											
Rental Housing	Funds will be used to supplement the administration and RFP process	Affordable housing	Wayland	2017	2018	Affordability	Provide decent affordable housing	Rental units constructed	47	Household housing unit	Rental Housing

AP-35: Projects for City of Newton & WestMetro HOME Consortium for FY17

#133-16

Project Name	Target Area (if applicable)	Priority Needs Addressed	Project Description	Estimated Funding Allocation	Target Date of Completion	Estimate the number and type of families that will benefit from the proposed activities:	Planned Activities:
Housing Rehabilitation and Development Program Fund (CDBG)	N/A	Affordable housing near amenities; provide affordable housing in mixed-income developments; additional accessible rental units and visitable housing; increase production of new affordable housing units; housing rehab; aging in place	CDBG funds will be used for the following purposes: 1. rehabilitation of owner-occupied one- and two-family residential structures, owner-occupied condominium units and rental units owned by the Newton Housing Authority and nonprofit affordable housing development organizations and providers; 2. acquisition of housing units for permanently restricted affordable housing; 3. write down of mortgages for the purpose of creating permanently restricted affordable housing; and 4. the preservation of existing affordable housing.	\$ 568,399.00	6/30/2017	Extremely low-, low-, and moderate-income families will benefit from this project. The number of families is to be determined.	TBD
Housing Program Rehab Revolving Loan Fund (CDBG)	N/A	Housing rehab; aging in place	Estimated program income from repayment of housing rehabilitation loans to be used for new housing rehabilitation projects.	\$ 81,250.00	6/30/2017	Extremely low-, low-, and moderate-income families will benefit from this project. The number of families is to be determined.	Receipt of program income from the repayment of housing rehabilitation loans to be used for new housing rehabilitation projects. Approximately 7 homeownership units will be rehabilitated in FY17.
Housing Program Delivery (CDBG)	N/A	All housing-related priority needs identified	Administrative services in support of developing new affordable housing and the rehabilitation and preservation of existing affordable housing. A portion of these funds may be used for Fair Housing activities.	\$ 390,000.00	6/30/2017	N/A	Administrative services and costs.
Public Services (CDBG)	N/A	Human services	Funds for public services for low- and moderate-income Newton residents focusing on the following populations: children and youth, disabled adults, adults and families, and elderly. Funding is comprised of 15% of FY17 CDBG Entitlement funds (\$261,375) plus 15% of FY16 program income (\$48,000 estimate)	\$ 309,375.00	6/30/2017	Extremely low-, low-, and moderate-income families will benefit from this project. The number of families is to be determined.	16 Human Service Grants have been awarded to 16 different agencies to provide services to children and youth, persons with disabilities, survivors of domestic violence, adults and families, and elderly.
Neighborhood Improvements (CDBG)	Target Neighborhood: Newton Corner	Neighborhood improvements	Funds for projects for improvements of (including but not limited to) public facilities, infrastructure, parks and open space, and accessibility.	\$ 87,125.00	6/30/2017	Extremely low-, low-, and moderate-income families will benefit from this project. The number of families is to be determined.	Project for the FY17 Newton Corner target neighborhood is TBD
Architectural Access (CDBG)	N/A	Architectural access	Funds for projects for improvements of (including but not limited to) public facilities, infrastructure, parks and open space, and accessibility.	\$ 87,125.00	6/30/2017	Extremely low-, low-, and moderate-income families will benefit from this project. The number of families is to be determined.	FY17 Curb Cuts funding pool.
Program Administration (CDBG)	N/A	All priority needs identified	Funds for the management and implementation of the CDBG program including citizen participation.	\$ 348,505.00	6/30/2017	N/A	Administrative services and costs.
HOME Administration	N/A	N/A	Funds for the administration of the WestMetro HOME Consortium, which is equal to 10% of the annual allocation. 7% of the allocation goes to local communities for administration of their projects. 3% of the allocation is set aside for general Consortium administration and compliance.	\$ 113,782.70	6/30/2017	N/A	Administrative services and costs.
Tenant-Based Rental Assistance (HOME)	N/A	Improve transition to permanent housing	Provide income-eligible renters with rent and/or security deposit assistance.	\$ 231,378.00	6/30/2017	One additionally income-eligible household will receive assistance in FY17, in addition to a continued second year of assistance for the 2 households assisted in FY16.	TBD
Homebuyer Assistance (HOME)	N/A	N/A	Funds for downpayment and closing cost assistance.	\$	6/30/2017	Extremely low-, low-, and moderate-income families will benefit from this project. The number of families is to be determined.	TBD
Housing Development (HOME)	N/A	Affordable housing near amenities; provide affordable housing in mixed-income developments; additional accessible rental units and visitable housing; increase production of new affordable units; promote private entities' use of other funding sources	Funds for the creation of new affordable housing units.	\$ 481,470.00	6/30/2017	Extremely low-, low-, and moderate-income families will benefit from this project. The number of families is to be determined.	TBD
Housing Rehabilitation (HOME)	N/A	Housing rehab; aging in place	Funds for single-family housing rehabilitation.	\$ 68,497.00	6/30/2017	Extremely low-, low-, and moderate-income families will benefit from this project. The number of families is to be determined.	TBD
CHDO Operating Expenses (HOME)	N/A	All housing-related priority needs identified for the WestMetro Consortium communities	Funds for operational expenses for Community Housing Organizations operating in the WestMetro HOME Consortium.	\$ 56,891.35	6/30/2017	N/A	Administrative services and costs.
CHDO Set-Aside (HOME)	N/A	Affordable housing near amenities; provide affordable housing in mixed-income developments; increase production of new affordable units	Funds reserved for CHDO acquisition projects	\$ 170,674.05	6/30/2017	Extremely low-, low-, and moderate-income families will benefit from this project. The number of families is to be determined.	CHDO projects are determined by an annual HOME RFP generally held in the fall.
Loan Repayment (HOME)	N/A	N/A	Repayment of loans from one WestMetro community to another	\$ 15,133.00	6/30/2017	N/A	Repayment of loans from WestMetro community to another.
ESG16 Newton	N/A	Supportive services; improve transition to permanent housing	Funds for the City of Newton are planned to operate shelters for the homeless, conduct street outreach activities, and provide homelessness prevention as well as support program administration.	\$ 159,211.00	6/30/2017	Extremely low-, low-, and moderate-income, and homeless families will benefit from this project. The number of families is to be determined.	Activities will include shelter services, street outreach, and homelessness prevention as well as support program administration, though agencies and funding amounts for each activity are to be determined.

WestMetro HOME Partnerships Program FY17 Projects

#133-16

DRAFT- This budget does not reflect inter-member loan repayments. Also waiting for HUD to release FFY2016 HOME consortia percentages. Final amounts may change.

Project #	Budget Code	Account Code	IDIS #	Environ. Review	PROJECT NAME/TYPE	FY17 Budget
BEDFORD						
HM17-01A	16R1141	5715		Exempt	Bedford HOME Administration	\$ 1,274.00
HM17-01B	16R1141	5797		Project by Project	Bedford Projects / Programs	\$ 12,744.00
TOTAL						\$ 14,018.00
BELMONT						
HM17-02A	16R1142	5715		Exempt	Belmont HOME Administration	\$ 3,584.00
HM17-02B	16R1142	5797		Project by Project	Belmont Projects / Programs	\$ 35,841.00
TOTAL						\$ 39,425.00
BROOKLINE						
HM17-03A	16R1143	5715		Exempt	Brookline HOME Administration	\$ 18,319.00
HM17-03B	16R1143	5797		Project by Project	Brookline Projects / Programs	\$ 183,190.00
TOTAL						\$ 201,509.00
CONCORD						
HM17-13A	16R11413	5715		Exempt	Concord HOME Administration	\$ 1,035.00
HM17-13B	16R11413	5796		Project by Project	Concord Projects / Programs	\$ 10,354.00
TOTAL						\$ 11,389.00
FRAMINGHAM						
HM17-09A	16R1149	5715		Exempt	Framingham HOME Administration	\$ 15,531.00
HM17-09B	16R1149	5797		Project by Project	Framingham Projects / Programs	\$ 155,313.00
TOTAL						\$ 170,844.00
LEXINGTON						
HM17-12A	16R11412	5715		Exempt	Lexington HOME Administration	\$ 2,469.00
HM17-12B	16R11412	5797		Project by Project	Lexington Projects / Programs	\$ 24,691.00
TOTAL						\$ 27,160.00
NATICK						
HM17-11A	16R11411	5715		Exempt	Natick HOME Administration	\$ 2,708.00
HM17-11B	16R11411	5797		Project by Project	Natick Projects / Programs	\$ 27,080.00
TOTAL						\$ 29,788.00
NEEDHAM						
HM17-05A	16R1145	5715		Exempt	Needham HOME Administration	\$ 1,593.00
HM17-05B	16R1145	5797		Project by Project	Needham Projects / Programs	\$ 15,930.00
TOTAL						\$ 17,523.00
NEWTON						
HM17-06A	16R1146	5715		Exempt	Newton HOME Administration	\$ 9,956.89
HM17-06B	16R1146	5797		Project by Project	Newton Projects / Programs	\$ 99,560.90
TOTAL						\$ 109,517.79
SUDBURY						
HM17-10A	16R11410	5715		Exempt	Sudbury HOME Administration	\$ 478.00
HM17-10B	16R11410	5797		Project by Project	Sudbury Projects / Programs	\$ 4,779.00
TOTAL						\$ 5,257.00
WALTHAM						
HM17-07A	16R1147	5715		Exempt	Waltham HOME Administration	\$ 16,885.00
HM17-07B	16R1147	5797		Project by Project	Waltham Projects / Programs	\$ 168,854.00
TOTAL						\$ 185,739.00
WATERTOWN						
HM17-08A	16R1148	5715		Exempt	Watertown HOME Administration	\$ 5,098.00
HM17-08B	16R1148	5797		Project by Project	Watertown Projects / Programs	\$ 50,974.00
TOTAL						\$ 56,072.00
WAYLAND						
HM17-14A	16R11414	5715		Exempt	Wayland HOME Administration	\$ 717.00
HM17-14B	16R11414	5797		Project by Project	Wayland Projects / Programs	\$ 7,168.00
TOTAL						\$ 7,885.00
CONSORTIUM ADMINISTRATION						
HM17-99	16R11415	5715		Exempt	Consortium HOME Administration	\$ 34,134.81
HM17-15A	16R11415	5797		Project by Project	Competitive Funding Pool	\$ -
HM17-15B	16R11415	5797		Underway	CHDO Operating Expenses Funding Pool	\$ 56,891.35
HM17-15C	16R11415	5797		Project by Project	CHDO Set Aside Funding Pool	\$ 170,674.05
TOTAL						\$ 261,700.21

TOTAL FY17 HOME CONSORTIUM BUDGET \$ 1,137,827.00

FY17 HOME Consortium Letter of Credit Funds M16-DC25-0213 \$ 1,137,827.00

FY17 HOME is a 1.08% increase from FY16 (\$1,125,677)

HOME Projects and Programs	\$796,478.90
Total Administrative Costs (10% of total allocation)	\$113,782.70
Local Administration (7% of total allocation)	\$79,647.89
Consortium Administration (3% of total allocation)	\$34,134.81
Total CHDO Operating Expenses (5% of total allocation)	\$56,891.35
Total CHDO Set-Aside (15% of total allocation)	\$170,674.05
TOTAL FY17 HOME CONSORTIUM BUDGET	\$1,137,827.00

Newton Emergency Solutions Grants Program - FY17 Budget

Service Area Split Per Continuum of Care unanimous vote on 3.28.2016

Project Number	Envir. Review	IDIS #	ESG PROJECTS	BUDGET CODE	ACCOUNT	ACCOUNT TITLE	ESG Funds
HES16-01	Exempt		Emergency Shelter Services A	18A11416	5797	Grants	\$ 63,684.00
HES16-02	Exempt		Emergency Shelter Services A	18A11416	5797	Grants	
HES16-03	Exempt		Emergency Shelter Services A	18A11416	5797	Grants	
HES16-04	Exempt		Homelessness Prevention Services	18A11416	5797	Grants	\$ 44,579.00
HES16-05	Exempt		ESG Administration	18A11416	5797	Grants	\$ 11,941.00
HES16-06	Exempt		HMIS Operation and Administration	18A11416	5797	Grants	\$ -
HES16-07	Exempt		Rapid Re-housing Services	18A11416	5797	Grants	\$ 23,086.00
HES16-08	Exempt		Emergency Shelter Services D	18A11416	5797	Grants	
HES16-09	Exempt		Street Outreach Activities	18A11416	5797	Grants	\$ 15,921.00
TOTAL							\$ 159,211.00
FY17 ESG Letter of Credit Funds E16-MC-25-0010							\$ 159,211.00

FY17 ESG is a .19% decrease from FY16 (\$159,511)

Final projects to be determined after RFQ process in FY16 Qtr 4

Newton Community Development Block Grant Program - FY17 Budget- DRAFT

PROJECT #	IDIS #	Env. Review	Budget Code	Account	Projects	Letter-of-Credit (LOC) Budget	FY17 Program Income (Estimated)	Prior Year(s) Program Income (FY16)	Total Budget	
HOUSING PROGRAM										
CD17-01A		Exempt	15V114	Various	Housing Program Delivery	\$390,000.00			\$390,000.00	
CD17-01B		project by project	15V114	5796	Housing Rehabilitation and Development Program Fund	\$568,399.00			\$568,399.00	
CD17-01C		project by project	15V114	5796C	Housing Program Rehab Revolving Loan Fund (estimated re	\$0.00	\$81,250.00		\$81,250.00	
HOUSING PROGRAM TOTAL						\$958,399.00	\$81,250.00	\$0.00	\$1,039,649.00	
ARCHITECTURAL ACCESS										
CD17-03A		project by project	15V114	586001	FY17 Curb Cuts	\$87,125.00			\$87,125.00	
ARCHITECTURAL ACCESS TOTAL						\$87,125.00	\$0.00	\$0.00	\$87,125.00	
HUMAN SERVICES										
CD17-05A		Exempt	15V114	5797	Barry Price Rehabilitation Center / Building Independence and Self-Esteem Through Employment	\$17,500			\$17,500.00	
CD17-05B		Exempt	15V114	5797	Boys and Girls Club/Financial Aid for Teens and Families	\$12,500			\$12,500.00	
CD17-05C		Exempt	15V114	5797	Crittenton Women's Union / Career Family Opportunity Program	\$19,000		\$ 30,000	\$49,000.00	
CD17-05D		Exempt	15V114	5797	Family ACCESS of Newton / Social Mobility for Young Families	\$50,000			\$50,000.00	
CD17-05F		Exempt	15V114	5797	Jewish Community Housing for the Elderly / Caring Choices and Wellness Nursing for Low-Income Seniors	\$12,500			\$12,500.00	
CD17-05G		Exempt	15V114	5797	Newton Community Development Foundation / Resident Services Program	\$20,000			\$20,000.00	
CD17-05H		Exempt	15V114	5797	Newton Partnership/Child Care Scholarship Fund	\$17,500			\$17,500.00	
CD17-05I		Exempt	15V114	5797	Newton Housing Authority / Resident Services Program	\$12,875			\$12,875.00	
CD17-05L		Exempt	15V114	5797	Newton Public Schools / Transition to High School Summer Program for Students at Academic Risk	\$10,000			\$10,000.00	
CD17-05M		Exempt	15V114	5797	REACH / Individual Support and Advocacy including Emergency Hotline and Community Outreach	\$10,000			\$10,000.00	
CD17-05N		Exempt	15V114	5797	Riverside Community Care / Mental Health Services Promoting Economic Mobility	\$40,000			\$40,000.00	
CD17-05O		Exempt	15V114	5797	The Second Step / Residential and Community Programs for Survivors of Domestic Violence	\$20,000			\$20,000.00	
CD17-05P		Exempt	15V114	5797	West Suburban YMCA / Future Leaders	\$19,500			\$19,500.00	
CD17-98D		Exempt	15V114	5797	Human Service Program Income Reserve (for FY17 projects-do not include in FY16 budget totals)		\$18,750			
HUMAN SERVICES TOTAL (Cannot exceed 15% of current year LOC + 15% of prior year program income)						\$261,375.00	\$18,750.00	\$30,000.00	\$291,375.00	
<i>Tier 2 Awards: These three projects will be funded with program income earned March-June 2016. Funds to be split evenly among the three projects.</i>				CD17-05E	Horace Cousens Industrial Fund / Emergency Payment for Families in Financial Crisis			\$6,000 ESTIMATE		
				CD17-05J	NWW Committee / Wednesday Night Drop-In			\$6,000 ESTIMATE		
				CD17-05K	Plowshares Education Development Center / Tuition Assistance for Preschool and After School			\$6,000 ESTIMATE		
NEIGHBORHOOD IMPROVEMENTS										
CD17-08V		project by project	15V114	5797	Newton Corner Project TBD	\$87,125.00			\$87,125.00	
NEIGHBORHOOD IMPROVEMENTS TOTAL						\$87,125.00	\$0.00	\$0.00	\$87,125.00	
PROGRAM ADMINISTRATION										
CD17-09A		Exempt	15V114	Various	Program Administration	\$347,505.00	\$25,000.00		\$372,505.00	
CD17-09B		Exempt	15V114	Various	Citizen Participation	\$1,000.00			\$1,000.00	
CD17-99		Exempt	15V114	5797	Contingencies	\$0.00				
STRATION TOTAL (Cannot exceed 20% of current year LOC + 20% of current year program income- must also include Planning activities)						\$348,505.00	\$25,000.00	\$0.00	\$373,505.00	
GRAND TOTAL ALL PROGRAM AREAS						\$1,742,529.00	\$125,000.00	\$30,000.00	\$1,791,654.00	
FY17 CDBG Letter of Credit Funds from HUD B-16-MC-25-0019						\$1,742,529.00				

* FY17 CDBG is a 1.48% decrease from FY16 (\$1,768,620)

Section 1.5.1.B. Two-Family, Detached

Illustrations

Fig. 1 Vertical crosswise

Fig.2 Horizontal

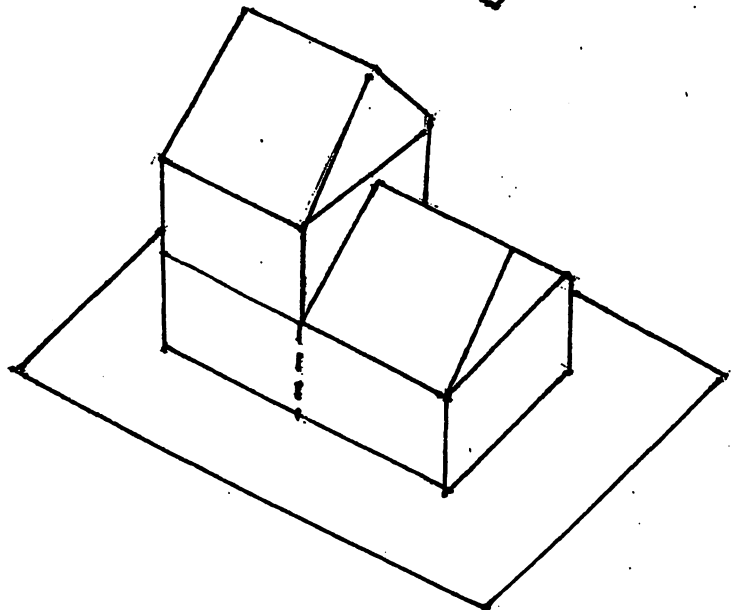
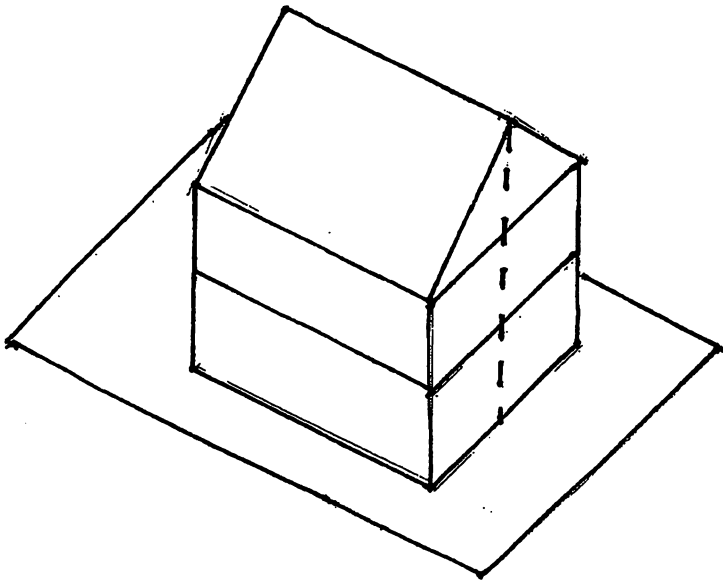
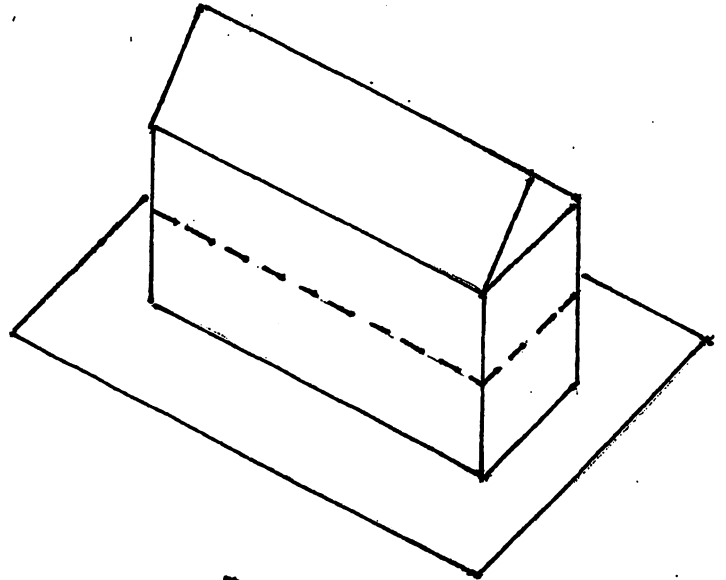
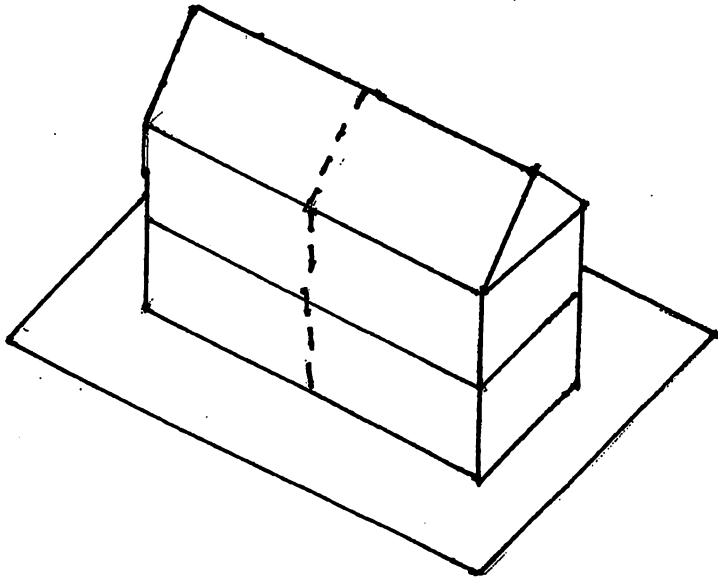

Fig. 3 Vertical Lengthwise

Fig. 4 Vertical 2.5 & 1.5 story units

DRAFT

CITY OF NEWTON

IN CITY COUNCIL

_____, 2016

RESOLUTION

TO THE MAYOR AND CITY COUNCIL REQUESTING THAT ALL MEMBERS OF MUNICIPAL PUBLIC BODIES THAT HAVE DECISION-MAKING AUTHORITY OR AN ADVISORY ROLE WITH RESPECT TO LAND USE, ZONING OR HOUSING ISSUES BE REQUIRED TO RECEIVE APPROPRIATE ORIENTATION OR TRAINING CONCERNING APPLICABLE RIGHTS AND OBLIGATIONS UNDER FAIR HOUSING LAWS AND REGULATIONS.

BE IT RESOLVED:

WHEREAS, it is the policy of the City to see to it that each person shall have equal access to and equal opportunity in housing, regardless of race, color, religion, national origin, disability, age, sexual orientation, gender identity or expression, marital status, familial status (families with children under 18), public assistance (including rental vouchers), genetic information, or military status; and

WHEREAS, the goal of this policy is to ensure that Newton is an open, diverse, and welcoming community free from discrimination in any housing related activity, including but not limited to housing sales, leasing, and rentals, realtor and broker practices, housing development, construction, and management, advertising and listing practices, city housing planning, development, and zoning activities, and home mortgage, lending and insurance practices; and

WHEREAS, unlawful discrimination may involve policies or actions taken with a discriminatory intent or purpose, or it may be the result of neutral practices or actions which have a discriminatory effect based on prohibited grounds, and such discriminatory effect may take the form of a disparate impact on a protected class, or it may involve reinforcement or perpetuation of segregated housing patterns; and

WHEREAS, Fair Housing requirements apply to all types of housing, whether private or public, with very few limited exemptions, and regardless of whether government financial assistance is received; and

WHEREAS, It is the City's intention to follow all the non-discrimination provisions and the affirmative duty to further Fair Housing obligations set forth in the applicable federal, state and local Fair Housing laws, and that, as a general matter, the affirmative duty to further Fair Housing means, according to regulations of the U.S. Department of Housing and Urban Development, "taking meaningful actions, in addition to combating discrimination, that overcome patterns of segregation and foster inclusive communities free from barriers that restrict access to opportunity based on protected characteristics"; and

WHEREAS, the City of Newton has entered into a Conciliation and Voluntary Compliance Agreement (the "Agreement") to resolve claims of violations of the Fair Housing Act, Americans with Disabilities Act and Section 504 of the Rehabilitation Act of 1973, which was approved by the United States Department of Housing and Urban Development on May 12, 2015; and

WHEREAS, the Agreement provides that City employees shall receive training on Fair Housing requirements as necessary to ensure that the City's policies and actions comply with Fair Housing laws and regulations; and

WHEREAS, all members of municipal public bodies that have decision-making authority or an advisory role relating to land use, zoning and housing issues, including but not limited to the City Council, Zoning Board of Appeals, Planning and Development Board, the Community Preservation Committee, the Newton Housing Partnership, and the Fair Housing Committee, should therefore be familiar with Fair Housing requirements;

NOW THEREFORE BE IT RESOLVED, that this Council hereby requests that all members of municipal public bodies that have decision-making authority or an advisory role with respect to land use, zoning or housing issues be required to receive appropriate orientation or training concerning applicable rights and obligations under Fair Housing laws and regulations.

CITY OF NEWTONIN CITY COUNCIL

[Date]

ORDINANCE NO. _____

BE IT ORDAINED BY THE CITY COUNCIL
OF THE CITY OF NEWTON AS FOLLOWS:

That the Revised Ordinances of Newton, Massachusetts, 2012, as amended, be and are hereby further amended as follows:

Add **Section 22-7 Statement on Fair Housing Required in Notices of Public Hearings and Meetings Relating to Permitting or Funding of Housing to Chapter 22 Planning and Development**, as follows:

Section 22-7 Statement on Fair Housing Required in Notices of Public Hearings and Meetings Relating to Permitting or Funding of Housing

(a) In all cases where notice of a public hearing or meeting relating to the permitting or funding of housing is required by the Massachusetts General Laws or the Revised Ordinances, as amended, such notice shall contain a brief statement concerning the City's policy regarding fair housing practices, the Equal Housing Opportunity logo of the United States Department of Housing and Urban Development, and the name, title, telephone number and email address of a person in the Department of Planning and Development to contact for more information regarding fair housing, as follows:

It is the policy of the City of Newton to see to it that each person shall have equal access to and equal opportunity in housing, regardless of race, color, religion, national origin, disability, age, sexual orientation, gender identity or expression, marital status, familial status (families with children under 18), public assistance (including rental vouchers), genetic information, or military status. Fair housing requirements apply to all types of housing, public and private, with very few limited exemptions, and regardless of whether government financial assistance is received.



For more information regarding fair housing, please contact [name, title, telephone number, email address].

(b) In all cases where notice of a public hearing or meeting relating to the permitting or funding of housing is required to be sent to individuals or specific boards or other agencies by the Massachusetts General Laws or the Revised Ordinances, as amended, such notice shall be accompanied by a copy of the Newton Fair Housing Committee’s “Statement on Fair Housing in Newton.”

(c) This Section applies to any public hearing or meeting concerning: (i) a petition for a development requiring a special permit which is proposed to include or may include at least 1 new dwelling unit that satisfies the requirements for the provisions of an affordable housing “inclusionary unit” as set out in Section 5.11; (ii) a petition for a special permit to allow an association of persons to live in a common dwelling pursuant to the provisions of Chapter 30, Section 6.2.6; (iii) a petition for a special permit to allow an association of persons to live in a congregate living facility pursuant to the provisions of Chapter 30, Section 6.2.8; (iv) a petition for a comprehensive permit pursuant to M.G.L. Chapter 40B; and (v) any request for public funding to subsidize the creation or preservation of affordable housing.

Under Suspension of Rules
Readings Waived and Adopted
__ yeas and __ nays __ absent

Approved as to legal form and character:

DONNALYN B. LYNCH KAHN
City Solicitor

(SGD) DAVID B. OLSON
City Clerk

(SGD) SETTI D. WARREN
Mayor

Date: _____

STATEMENT ON FAIR HOUSING IN NEWTON

- It is the policy of the City to see to it that each person shall have equal access to and equal opportunity in housing, regardless of race, color, religion, national origin, disability, age, sexual orientation, gender identity or expression, marital status, familial status (families with children under 18), public assistance (including rental vouchers), genetic information, or military status.
- The goal of this policy is to assure that Newton is an open, diverse, and welcoming community free from discrimination in any housing related activity, including but not limited to housing sales, leasing, and rentals; realtor and broker practices; housing development, construction, and management; advertising and listing practices; city housing planning, development, and zoning activities; and home mortgage, lending and insurance practices.
- Unlawful discrimination may involve policies or actions taken with a discriminatory intent or purpose, or it may be the result of neutral practices or actions which have a discriminatory effect based on prohibited grounds. The discriminatory effect may take the form of a disparate impact on a protected class, or it may involve reinforcement or perpetuation of segregated housing patterns.
- Fair housing requirements apply to all types of housing with very few limited exemptions*, whether they are in the private or public real estate sectors, and regardless of whether government financial assistance is received.
- It is the City's intention to follow all the non-discrimination provisions and the affirmative duty to further fair housing obligations set forth in the applicable federal, state and local fair housing laws. As a general matter, the affirmative duty to further fair housing means, according to regulations of the U.S. Department of Housing and Urban Development, "taking meaningful actions, in addition to combating discrimination, that overcome patterns of segregation and foster inclusive communities free from barriers that restrict access to opportunity based on protected characteristics."

*For any question about the applicability of fair housing law, please consult with an experienced attorney

