

# Article 2. General Standards

|                                                               |             |                                                |             |
|---------------------------------------------------------------|-------------|------------------------------------------------|-------------|
| <b>Sec. 2.1. Purpose</b> .....                                | <b>2-2</b>  | <b>Sec. 2.9. Outdoor Amenity Space</b> .....   | <b>2-14</b> |
| 2.1.1. Purpose .....                                          | 2-2         | 2.9.1. Definition .....                        | 2-14        |
| 2.1.2. Applicability .....                                    | 2-2         | 2.9.2. Standards .....                         | 2-14        |
| <b>Sec. 2.2. Lots</b> .....                                   | <b>2-2</b>  | <b>Sec. 2.10. Public Gathering Space</b> ..... | <b>2-14</b> |
| 2.2.1. Lot Definitions .....                                  | 2-2         | 2.10.1. Definition .....                       | 2-14        |
| 2.2.2. Lot Types .....                                        | 2-3         | 2.10.2. Standards .....                        | 2-14        |
| <b>Sec. 2.3. Lot Standards and Setbacks</b> .....             | <b>2-4</b>  |                                                |             |
| 2.3.1. Lot Frontage .....                                     | 2-4         |                                                |             |
| 2.3.2. Lot Coverage .....                                     | 2-4         |                                                |             |
| 2.3.3. Setback Definitions .....                              | 2-4         |                                                |             |
| 2.3.4. Setback Standards .....                                | 2-4         |                                                |             |
| 2.3.5. Setback Encroachments .....                            | 2-5         |                                                |             |
| 2.3.6. Frontage Buildout .....                                | 2-5         |                                                |             |
| <b>Sec. 2.4. Building Types and Components</b> .....          | <b>2-6</b>  |                                                |             |
| 2.4.1. Building Types .....                                   | 2-6         |                                                |             |
| 2.4.2. Building Type General Standards .....                  | 2-6         |                                                |             |
| 2.4.3. Determining Building Type for Existing Buildings ..... | 2-6         |                                                |             |
| <b>Sec. 2.5. Building Footprint</b> .....                     | <b>2-6</b>  |                                                |             |
| 2.5.1. Measuring Building Footprint .....                     | 2-6         |                                                |             |
| 2.5.2. Building Components .....                              | 2-6         |                                                |             |
| <b>Sec. 2.6. Height and Massing</b> .....                     | <b>2-7</b>  |                                                |             |
| 2.6.1. Intent and Purpose .....                               | 2-7         |                                                |             |
| 2.6.2. Definitions .....                                      | 2-7         |                                                |             |
| 2.6.3. Building Height Standards .....                        | 2-7         |                                                |             |
| 2.6.4. Building Massing Standards .....                       | 2-12        |                                                |             |
| <b>Sec. 2.7. Front Elevation Composition</b> .....            | <b>2-12</b> |                                                |             |
| 2.7.1. Definitions .....                                      | 2-12        |                                                |             |
| 2.7.2. Fenestration Standards .....                           | 2-13        |                                                |             |
| 2.7.3. Blank Wall Area .....                                  | 2-13        |                                                |             |
| <b>Sec. 2.8. Residential Units Factor</b> .....               | <b>2-14</b> |                                                |             |
| 2.8.1. Definition .....                                       | 2-14        |                                                |             |
| 2.8.2. Intent and Purpose .....                               | 2-14        |                                                |             |
| 2.8.3. Calculation .....                                      | 2-14        |                                                |             |

## Sec. 2.1. Purpose

### 2.1.1. Purpose

The purpose of this section is to explain the dimensional standards of this ordinance, defining how each is measured and providing generally applicable rules, standards, and reference information.

### 2.1.2. Applicability

The rules and standards described in this Article apply to all development in the City.

## Sec. 2.2. Lots

### 2.2.1. Lot Definitions

- A. **Lot.** An area of land with definite boundaries established by deed and/or a plan recorded in the Registry of Deeds, undivided by a street (except where allowed by the Zoning District).
- B. **Lot Area.** The horizontal measurement of a lot in square feet, exclusive of area in a street.
- C. **Lot Coverage.** The percentage of lot area that is covered by structures, impermeable surfaces, paving, pavers, and decking. The lot coverage standard is intended to differentiate between the built and unbuilt aspects of a lot. Buildings are measured from the outer edge of the walls and include cantilevered portions of building, exclusive of the area under the eaves. Any area used for parking, no matter the surface material, is counted in the lot coverage.

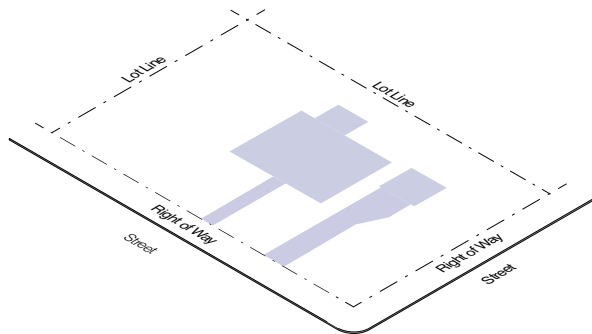

### D. Lot Dimensions.

1. **Lot Frontage.** Lot frontage is the length of the primary front lot line of a lot.

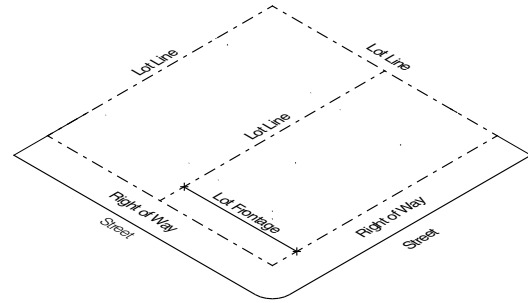

2. **Lot Depth.** Lot depth is the horizontal distance between the midpoint of the primary front lot line and the midpoint of the rear lot line or, if there is no rear lot line, to the most distant point on any other lot line.

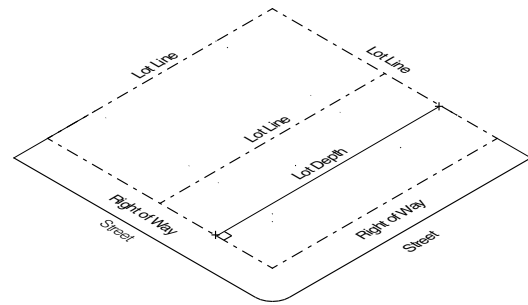

- E. **Lot Line.** A boundary line that demarcates a lot.
- F. **Front Lot Line.** Any lot line abutting a street is a front lot line.
  1. **Primary Front Lot Line.** Where there are multiple front lot lines, one is designated a primary front lot line.
    - a. At time of application for a building permit or other municipal approval for which the location of the front lot line must be established, the property owner of such a lot may designate a Primary Front Lot Line which will be utilized to measure lot frontage. The other secondary front lot line continues to be a front lot line.

- G. **Rear Lot Line.** Any lot line which is parallel to or within 45 degrees of being parallel to a front lot line. If what would be a rear lot line is a side lot line of an abutting property, it is considered a side lot line.
- H. **Side Lot Line.** Any lot line other than a front or rear lot line.

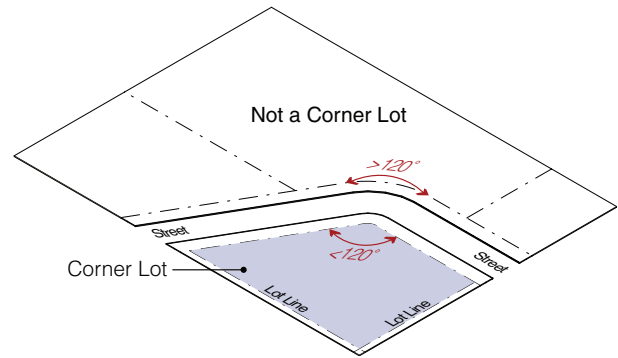
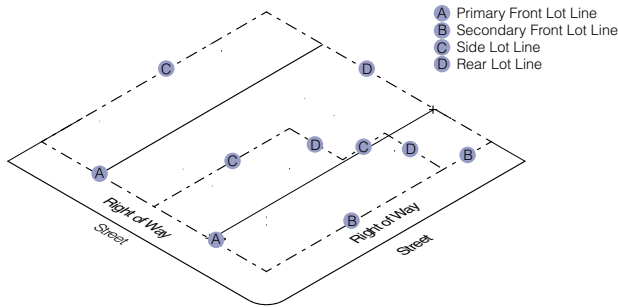

- I. **Front Elevation.** The exterior wall of a building oriented in whole or in part toward the primary front lot line.

- 2. The frontage along the primary front lot line runs from the intersection of the two front lot lines to the intersection of the primary front lot line with the side lot line.

- C. **Through Lot.** A lot with frontage on two or more non-intersecting streets.

**2.2.2. Lot Types**

- A. **Interior Lot.** A lot with frontage on a single street.

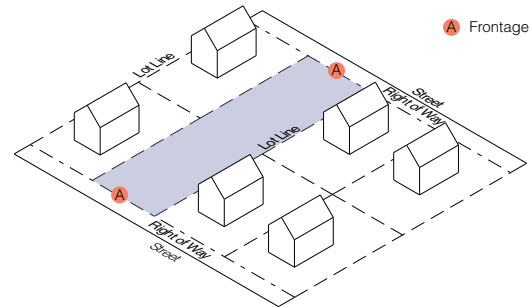
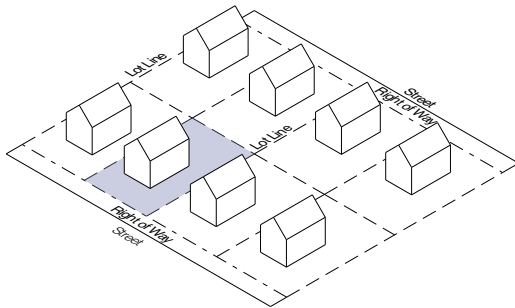

- B. **Corner Lot.** A lot with frontage on two intersecting streets or at the bend in a street.

- D. **Rear Lot.** See Sec. 3.4.2.
- E. **Waterfront Lot.** A lot with frontage on a street and a body of water.

- 1. A corner lot occurs when:
  - a. Two streets intersect at an interior angle of 120 degrees or less
  - b. A bend in the street forms an interior angle of 120 degrees or less
  - c. A curve in a street or at the intersection of two streets where the tangent lines of the curve form an angle of 120 degrees or less when extended into the intersection.

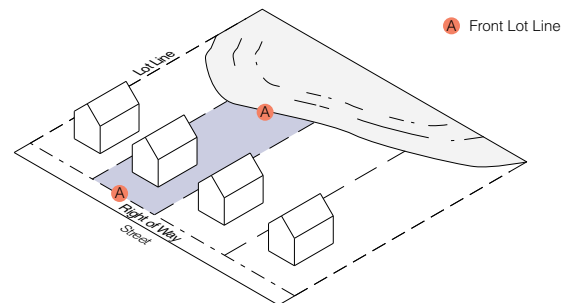

## Sec. 2.3. Lot Standards and Setbacks

### 2.3.1. Lot Frontage

- A. All lots must have no less and no more than the minimum and maximum lot frontage established for the zoning district in which the lot is located. See Article 10 for rules applying to nonconforming lots.

### 2.3.2. Lot Coverage

- A. All lots are required to meet the lot coverage standard established for the zoning district in which the lot is located.
- B. Lot coverage may be increased through Special Permit up to 10% beyond the maximum standard established for the zoning district in which the lot is located.
  - 1. Increasing lot coverage within 10% of the maximum established for the zoning district requires a Special Permit. The Special Permit Granting Authority is determined by the scale of the project (See Secs. 3.1, 4.1, 5.1, and 6.1).
  - 2. Review Criteria. In its discretion to approve or deny a Special Permit authorizing an expansion of the lot coverage, the Special Permit Granting Authority must find that the application meets the following criteria:
    - a. The criteria for a Special Permit specified in Sec. 11.4.3.
    - b. Design and landscaping is compatible with the neighborhood and adjacent properties.
    - c. Methods to address stormwater runoff on neighboring properties and public infrastructure meet or exceed the standards of Sec. 8.3.
    - d. The landscaped areas and trees included address the heat island effect.

### 2.3.3. Setback Definitions

- A. **Setback.** A line parallel to a lot line that establishes where a structure or parking area may be placed. Setbacks are understood to represent a vertical plane rather than a point on the ground. A minimum

setback establishes the nearest point to the lot line where any part of a structure or parking area may be placed.

- 1. **Maximum Front Setback.** A maximum front setback establishes the furthest point from the lot line where the front elevation may be located.
- B. **Setback Area.** The area between the minimum and maximum front setback.

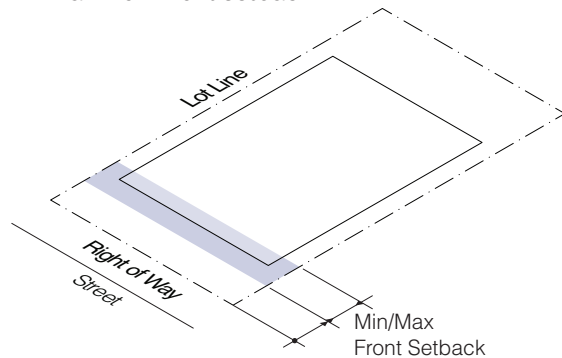

### 2.3.4. Setback Standards

#### A. Building Setbacks

- 1. All buildings and structures must be located no closer to an adjoining lot or street line than any required minimum front, side, or rear setback, except as permitted in Sec 2.3.5.C.
- 2. The front elevation of a principal building must be built no further from the front lot line than the required maximum front setback.

#### B. Parking Setbacks

Parking Lots and Parking Structures, excluding underground parking, must be located at or behind any required minimum parking setback.

- 1. If a lot has more than one front lot line, the parking setback is only taken from the primary front lot line.

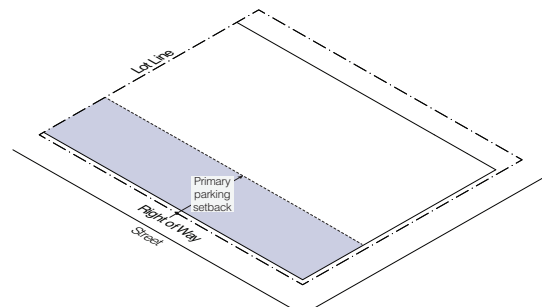

**C. Specific Setback Rules for Buildings and Structures on Waterfront Lots.**

1. Accessory buildings and structures on waterfront lots may be located forward of the front elevation along the street frontage, but not within the front setback area.

**2.3.5. Setback Encroachments.**

- A. Building components may extend in front of a required minimum front setback as indicated for each type of component.
- B. Cornices, belt courses, sills, buttresses and other architectural features may encroach up to 2 feet into a minimum front or side setback.
- C. Building eaves and roof overhangs may encroach up to 3 feet into a minimum front or side setback, provided that at least 3 feet is maintained from any lot line.
- D. Insulation exterior to the walls of a building may encroach in the setback.
- E. Chimneys and flues may encroach up to 4 feet into a minimum side or rear setback, provided that they are at least 2 feet from of any lot line.
- F. Unenclosed fire escapes or emergency egress stairways may encroach up to 4 feet into a minimum side or rear setback, provided that they are at least 2 feet from any lot line.
- G. Mechanical equipment associated with residential uses, such as HVAC units and security lighting, may encroach into a minimum side or rear setback, provided that such equipment is at least 4 feet from any lot line.
  1. Mechanical equipment located in the setback must meet the requirements of the City of Newton Noise Ordinance (Chapter 20, Article II).
- H. Terraces, uncovered and unenclosed patios, driveways, and/or structures below and covered by the ground may fully encroach into any minimum setback.

- I. Minor structures accessory to utilities, such as hydrants, manholes, transformers, and other cabinet structures, may fully encroach into a minimum setback.
- J. Accessory structures, fences and walls, signs, and landscape buffers may encroach into minimum setbacks as indicated in Article 8.

**2.3.6. Frontage Buildout**

- A. Frontage buildout is the ratio of the width of the front elevation within the minimum and maximum setback as established by the district to the lot frontage.
- B. If a contextual front setback applies, the front elevation must meet the contextual front setback for a minimum of 40% of its width.

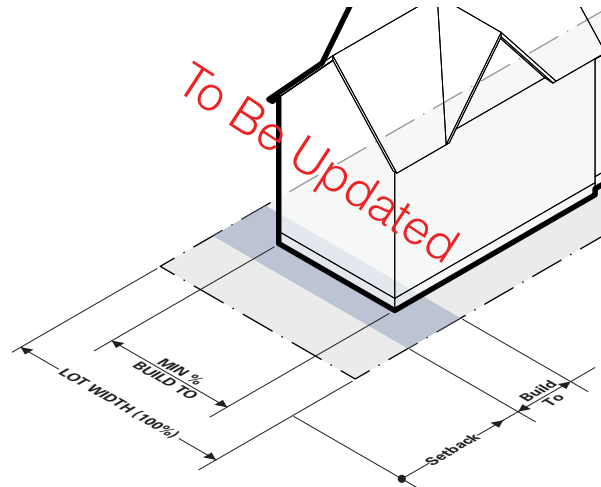

## Sec. 2.4. Building Types and Components

### 2.4.1. Building Types

Building type regulations are applicable in all zoning districts and include building standards for new construction, renovation of existing structures, and redevelopment.

Instead of applying generic dimensional standards to all principal structures, the use of Building Types as a regulatory tool allows dimensional standards to differ from one class or kind of structure to another within the same district.

### 2.4.2. Building Type General Standards

- A. Each building type may only be constructed in the zoning districts where that building type is allowed.
- B. Each building type may contain any of the uses permitted in the district in which it is located, unless otherwise specified.
- C. **No Other Building Types.** All principal buildings constructed must fulfill the requirements of one of the building types permitted in the zoning district where it is located.
- D. **Permanent Structures.** All principal buildings must be permanent construction without wheels or other features that would make the structure mobile, unless otherwise noted.

### 2.4.3. Determining Building Type for Existing Buildings

- A. The Commissioner of ISD is responsible for determining the building type classification of an existing building. Classification of existing buildings as building types is based on which building type the existing building most closely resembles.
- B. When determining which building type an existing building most closely resembles, the Commissioner of Inspectional Services will consider the following criteria:
  - 1. Use(s) and Number of Residential Units
  - 2. Height

### 3. Building Footprint

- C. A Property Owner may submit a written request to reassess the building type classification assigned to their property and receive a written decision in return. A property owner may also appeal the decision of the Commissioner of Inspectional Services to the Zoning Board of Appeals.

## Sec. 2.5. Building Footprint

### 2.5.1. Measuring Building Footprint

- A. Each building type has a maximum allowed footprint.
- B. The building footprint is measured from the outer edge of the exterior walls at the ground story and includes all enclosed spaces whether for habitation or storage. This includes building components on the ground story and attached garages.
- C. Unenclosed features, with and without roofs, attached to the building do not count toward the maximum building footprint. This includes attached decks, stoops, porticos, and porches. These features all count in the calculation of lot coverage and must not project into the setbacks.

### 2.5.2. Building Components

Building components are defined accessory features that attach to the building type and increase the habitable square footage or enhance the usefulness of a building. These components provide an important means for achieving variety and individuality in design of building front elevations and are permitted as indicated for each building type.

- A. Articles 3 and 4 include standards for building components along the front elevation that allow for minor encroachments in the front setback or over a public sidewalk.

## Sec. 2.6. Height and Massing

### 2.6.1. Intent and Purpose

- A. The height and massing measurement standards are written with an understanding that the height and bulk that a building presents toward the public street is one of the prime determinants of neighborhood character.
- B. The height and massing measurement standards are intended to enable and encourage a property owner to work with the existing grade of a site, whether flat or sloped. Earthworks to change the grade related to building height measurement are discouraged. Earthworks projects are subject to the Erosion and Sedimentation Control Permit regardless of intent.

### 2.6.2. Definitions

- A. **Average Ground Level.** The mean (average) grade of the finished ground level next to a building at the exterior walls as it existed prior to any site alteration in preparation for building.
- B. **Ground Story.** The lowest story of a building with a finished floor at or above the finished ground level at the front elevation.

### 2.6.3. Building Height Standards

- A. The total number of stories of a building is calculated as follows:
  - 1. The maximum number of stories is calculated along the front elevation.

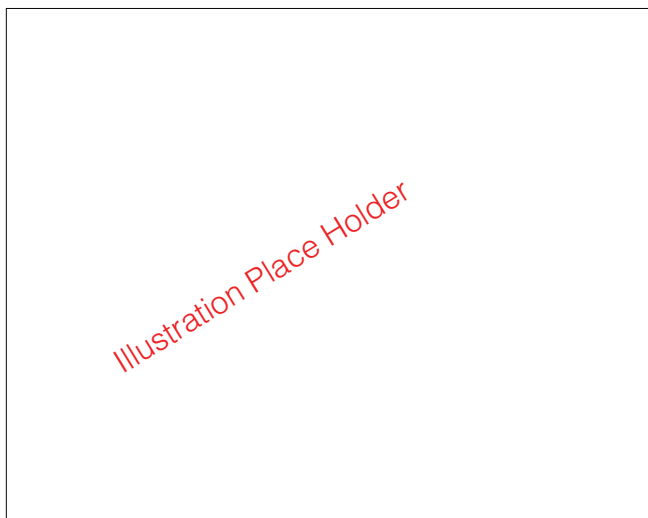

- 2. Ground Story and Basement:
  - a. A basement is counted as a story in the maximum number of stories when the finished floor of the ground story is 4 feet or more above the average ground level of the lot along the front elevation.
  - b. An exposed basement story along the front elevation is considered the ground story if it exceeds 50% of the width of the front elevation. An exposed basement story along the front elevation not exceeding 50% of the front elevation width is not counted toward the maximum number of stories.
  - c. A basement story exposed along a side or rear building wall, such as a walkout basement, is exempt from the maximum number of stories.
  - d. For any lot with frontage on 2 or more streets, the number of stories is calculated along the front elevation facing the primary front lot line.
- 3. Upper Stories:
  - a. Upper stories must comply with stated minimums and maximum story heights for the building type.
  - b. A half-story is the space located directly under a roof and is less than a full story. The following standards apply to half-stories:
    - i. The roof rafters must intersect the wall plate or top of wall frame of the exterior walls at a height no more than 2 feet above the finished floor of the half-story.
    - ii. Ceiling height of a half story must not exceed 12 feet at any point.
    - iii. Attic space located under a 0 story equivalent roof is not counted as a half story (See Sec 2.6.3.E on Roof Types).
- 4. Interior spaces may be configured to include multiple stories within the same interior volume.

- 5. Stories in Above Grade Structured Parking:
  - a. Each story of above ground structured parking is counted as 1 story regardless of its relationship to habitable stories, except that up to 2 stories of above ground structured parking may be counted as 1 story when those stories are fully screened by a single ground story with active uses of an equal or greater story height (See Lined Garage Building Type).

**B. Story Height**

- 1. Story height is measured vertically from the surface of the finished floor to the surface of the finished floor above. When there is no floor above, story height is measured from the surface of the finished floor to the top of the structural beam or joists above or the top of the wall plate, whichever is higher.
- 2. Minimum story height is not measured for half-stories.

**C. Ground Story Elevation.**

Ground story elevation is measured from the average ground level at the exterior walls. Subject to Site Plan Approval, a property owner may request that the grade be calculated from the grade of the sidewalk of the abutting street or from the crown of the roadway of the adjacent street when no sidewalk exists, to the top of the finished floor of the ground story of a building, where this provision will allow a more contextual building.

**D. Roof Types and Roof Components.**

- 1. Defined primary roof types and roof components are permitted as indicated for each building type.
- 2. Primary Roof Types.
  - a. General Standards.
    - i. Each Roof Type has a "story equivalent" based on the amount of potential living area available under the roof. The story equivalent, depending upon the roof type, may limit the number of stories in a building. Building types that are

permitted to have a 0.5 story may utilize a Roof Type equaling 0 or 1 story only if they do not build that 0.5 story.

- ii. Buildings may have more than one roof and roof type, provided that one roof type is used for at least 50% of the building footprint, the "primary roof type."
- iii. Any roof type may be used as a secondary roof type as long as the maximum stories is met.

**b. Gable Roof Type.**

- i. Description. A pitched roof with two sides meeting at a single ridge-beam.

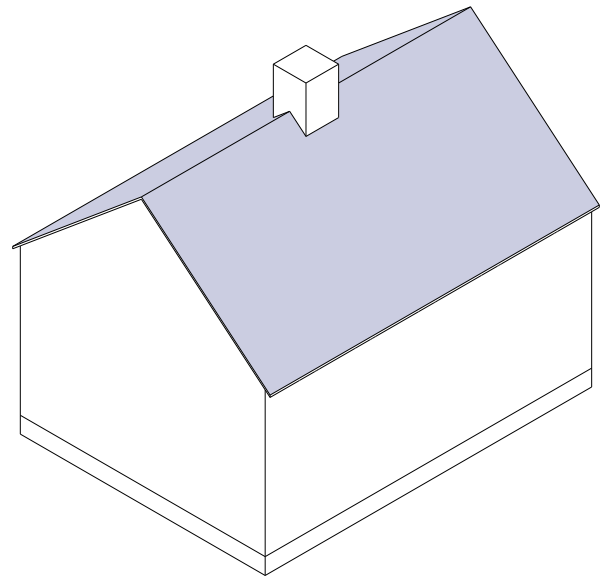

- ii. Story Equivalent. 0.5 story
- iii. Roof Pitch. - Min pitch = 6:12, Max pitch = 14:12

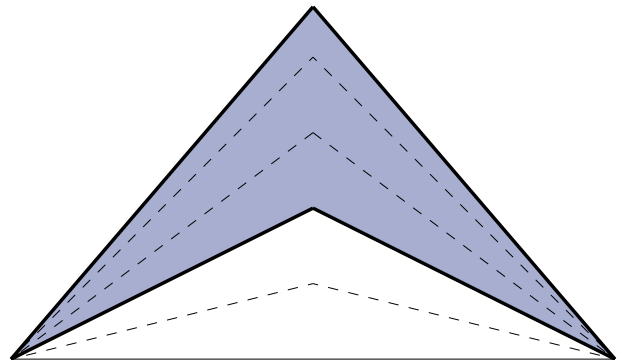



c. Low Gable Roof Type.

- i. Description. A pitched roof with two sides meeting at a single ridge-beam.

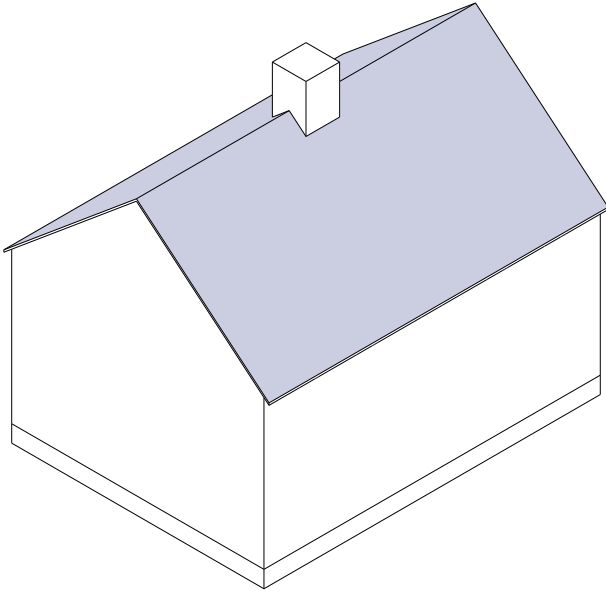

- ii. Story Equivalent. 0 story
- iii. Roof Pitch: Min pitch = 3:12, Max pitch = 6:12

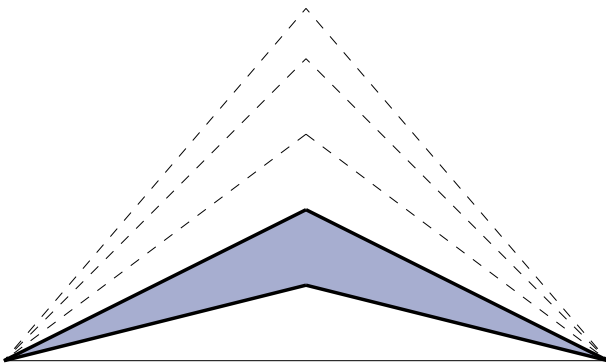

d. Hipped Roof Type.

- i. Description. A roof that is pitched on all sides meeting in a single point or ridge-beam.

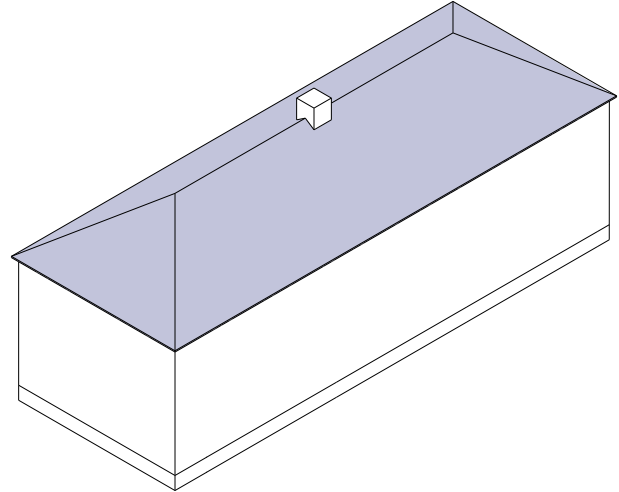

- ii. Story Equivalent. 0.5 story
- iii. Roof Pitch: Min pitch = 6:12, Max pitch = 12:12

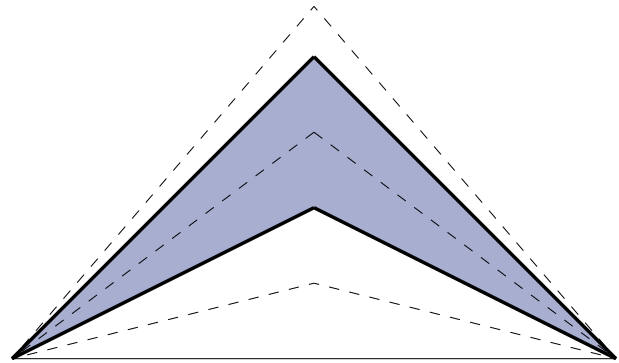

e. Low Hipped Roof Type.

- i. Description. A roof that is pitched on all sides meeting in a single point or ridge-beam.

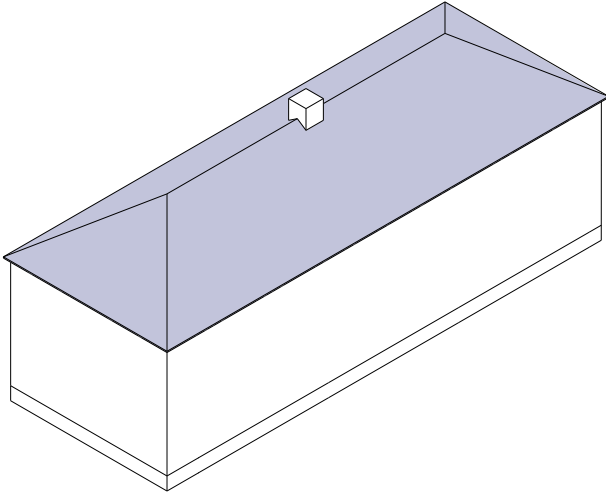

- ii. Story Equivalent. 0 story
- iii. Roof Pitch: Min pitch = 3:12, Max pitch = 6:12

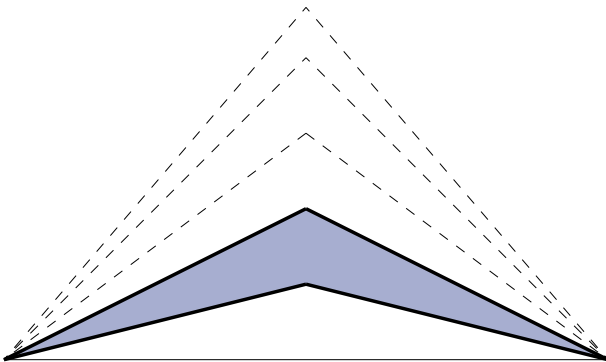

f. Two-Stage Roof Type.

- i. Description. A complex pitched roof consisting of a shallow sloped upper portion and a steeply sloped lower portion, meeting either in a single ridge-beam (like a gambrel roof) or a single point (like a mansard roof).

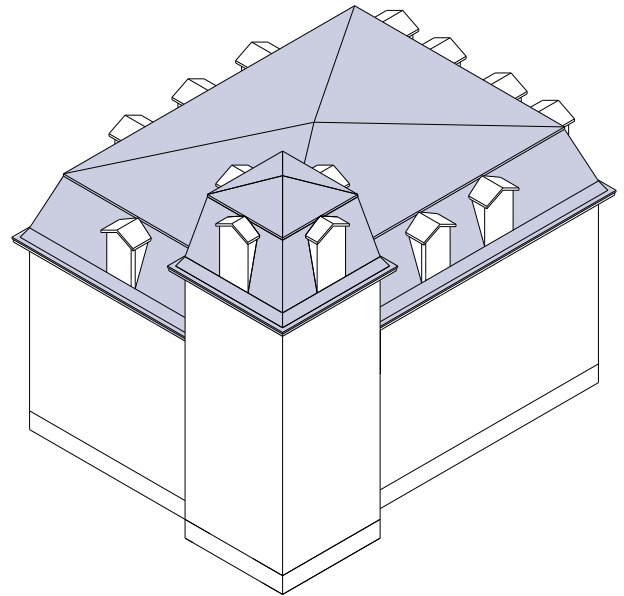
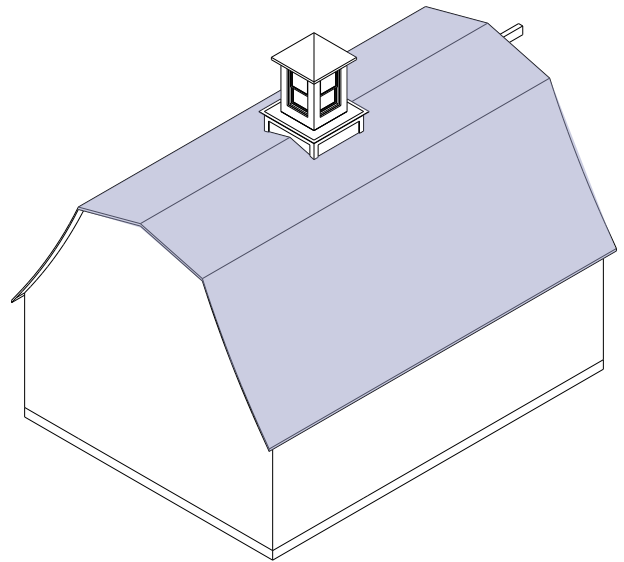

- ii. Story Equivalent. 1 story
- iii. Roof Pitch: Upper slope: Min pitch = 1.5:12, Max pitch = 3:12, Lower slope: Min pitch = 9:12, Max pitch = 60:12

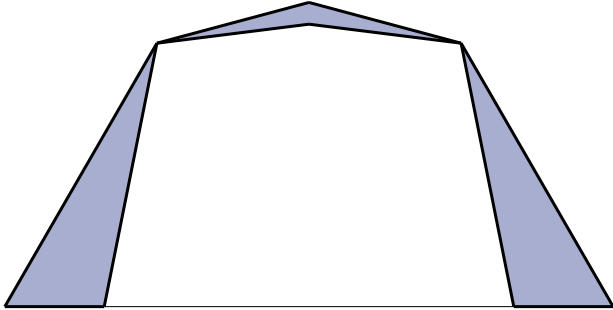

- iv. The point at which slope changes must be at least 8 ft but no more than 12 ft higher than the building eaves.

g. Vault Roof Type.

- i. Description. A roof formed by an arch, series of arches, or dome.
- ii. Story Equivalent. 1 story
- iii. The midpoint of the slope of the roof may be no more than 8 ft higher than the building eaves.

h. Flat Roof Type.

- i. Description. A roof with almost no pitch and no central ridge.

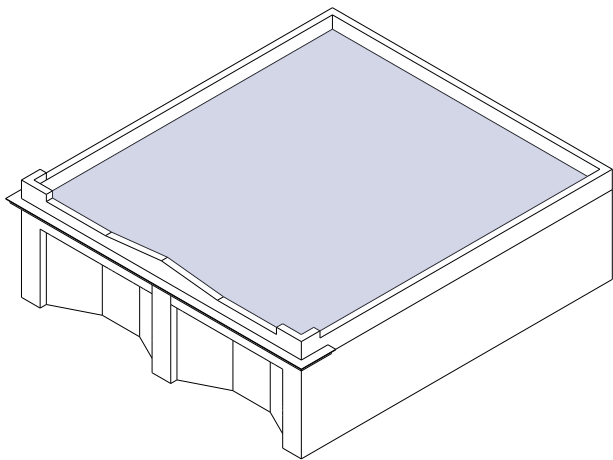

- ii. Story Equivalent. 0 story
- iii. Roof Pitch: Min pitch = 1.5:12, Max pitch = 3:12

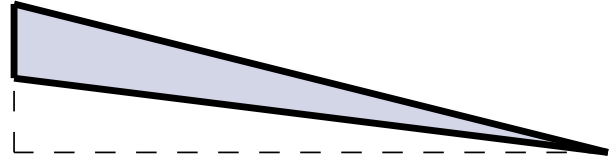

i. Shed Roof Type.

- i. Description. A pitched roof sloping in one direction from a single high ridge beam to a single low ridge beam.

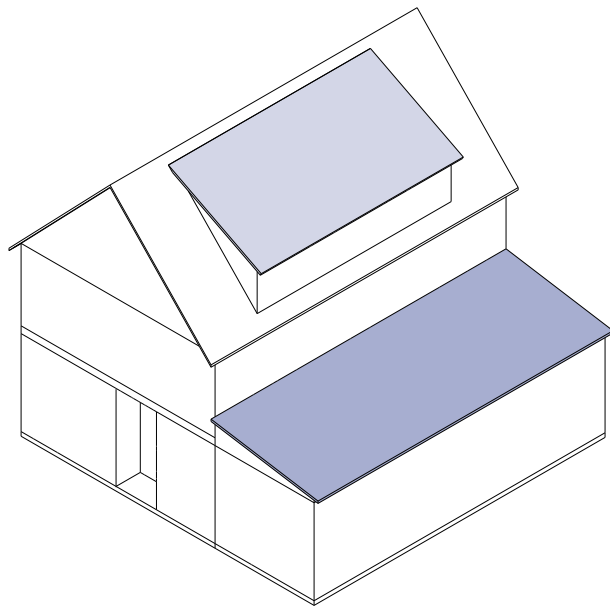

- ii. Story Equivalent. 0.5 story
- iii. The midpoint of the slope of the roof may be no more than 8 ft higher than the building eaves.

3. Rooftop Mechanicals.

The following rooftop mechanical systems are exempt up to a limit of 3 feet if unscreened or 8 feet if screened by parapet walls or similar opaque screening from view of the street.

- a. Roof mounted cellular, radio, and internet transmission equipment

- b. Skylights, vents and exhausts
  - c. Solar panels and solar hot water systems
  - d. Enclosed mechanical and stairwell penthouses
4. Rooftop Architectural Features.

Flagpoles, belfries, chimneys, cupolas, monuments, spires, steeples, and other non-habitable features are permitted on roofs and are exempt up to a height limit of 10 feet. Parapet walls are exempt to a height limit of 6 feet.

### 2.6.4. Building Massing Standards

#### A. Cantilevered Upper Stories

The upper stories of a building may not project in any direction beyond the exterior wall plane of the stories below, except for the following:

1. Cantilevered building massing counts toward lot coverage.
2. Permitted architectural components on the front elevation may project beyond the exterior wall of the stories below.
3. On a House A or House B, the second story may project up to 2 feet forward of the front elevation on the ground story.
4. The upper stories of a building may project up to 6 ft beyond the exterior wall plane of the stories below, with the exception of the front elevation, through cantilevering.
5. A Special Permit may be granted to allow cantilevering beyond 6 feet in any direction.
  - a. A Special Permit application for cantilevering shall be referred to the Urban Design Commission.
  - b. Review Criteria. In its discretion to approve or deny a special permit authorizing an expansion of the lot coverage, the Special Permit Granting Authority must find that the application meets the following criteria:
    - i. The criteria for all Special Permits specified in Sec. 11.4.3.

- ii. Design is compatible with the scale, massing, and fenestration of the proposed building type.
- iii. Design and landscaping is compatible with the neighborhood and adjacent properties.

#### B. Building Width

Building width is measured parallel to the front elevation of a building at the widest point of the building.

#### C. Building Depth

Depth is measured perpendicularly from the front elevation to the point on the rear wall most distant from the front elevation.

#### D. Floor Plate

Floor plate is measured as the total gross floor area of each story of a building, measured at the outer edge of exterior walls but excluding building components.

#### E. Floor Area

Floor area is measured as the total gross floor area of a building, addition, or portion of a building measured at the outer edge of exterior walls and summed across all floors. Where a measurement of floor area of a portion of the building (e.g. portion of non-residential floor area), it is measured to include the walls enclosing that space but does not include areas that are accessory to the portion of the building not being measured.

## Sec. 2.7. Front Elevation Composition

### 2.7.1. Definitions

#### A. Front Elevation

The exterior wall of a building oriented in whole or in part toward the primary front lot line.

#### B. Fenestration

The openings in a front elevation of a building, including windows and doors, but excluding entrances for parking, loading, and service facilities.

### 2.7.2. Fenestration Standards

- A. Fenestration must be provided as indicated for each building type and is calculated as a percentage of the area of a front elevation.
- B. Openings are measured by the size of the windows or doors or the size of the opening where neither are present.
- C. Ground story fenestration is measured between 2 and 12 feet above the finished grade.
- D. Upper story fenestration is measured independently for each story, from the top of the finished floor to the top of the finished floor above. There is no fenestration requirement for a half story.
- E. Fenestration enclosed with glazing may be included in the calculation if it meets the following criteria:
  1. For ground story fenestration, glazing must have a minimum 60% Visible Light Transmittance and no more than 15% Visible Light Reflectance.
  2. For upper story fenestration, glazing must have a minimum of 40% Visible Light Transmittance and no more than 15% Visible Light Reflectance.



### 2.7.3. Blank Wall Area

Blank Wall area is any portion of the front elevation that does not include fenestration and surface relief through the use of columns, cornices, moldings, sills, sign bands, and other architectural features that either recess or project from the average grade plane of the front elevation by at least 4 inches.

Blank wall area limitations apply both vertically and horizontally for all stories of a building for any front elevation.

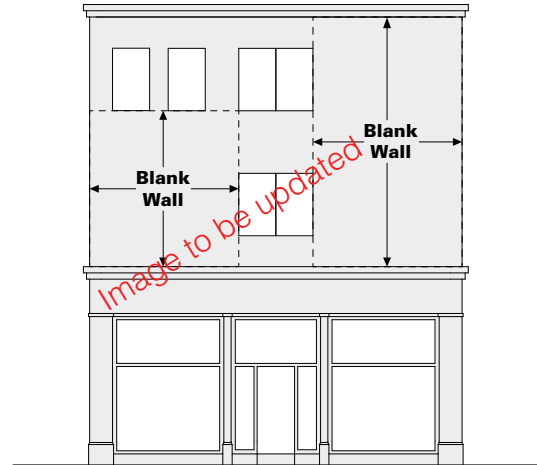

### 2.7.4. Principal Entrance Standards

- A. Principal entrance spacing is measured as the distance between the center lines of doors along a front elevation.
- B. Principal entrance spacing requirements must be met for each building individually but are not applicable to adjacent buildings.

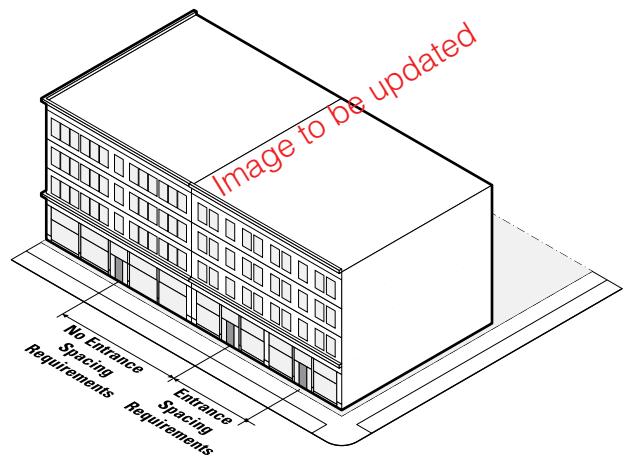

## Sec. 2.8. Residential Units Factor

### 2.8.1. Definition

The factor by which the maximum number of residential units permitted is calculated for a building.

### 2.8.2. Intent and Purpose

The residential unit factor relates the number of units directly to the size of the building.

- A. Two residential unit factors are given for each building type, a baseline and a bonus. The bonus residential units factor can be utilized if a project is 100% affordable units or meets the Sustainable Design Standards. Standards for when the bonus factor may be applied are articulated in Article 9. The bonus allows for more smaller units, but does not allow for an expanded building footprint.

### 2.8.3. Calculation

The maximum number of dwelling units permitted is equal to the gross floor area of a building, less any floor area for non-residential uses, divided by the applicable residential unit factor.

## Sec. 2.9. Outdoor Amenity Space

### 2.9.1. Definition

A feature of a lot or a building that provides outdoor social, recreational, and/or leisure space for the comfort and convenience of the residents of a building such as a balcony, deck, patio, porch, roof deck, terrace, or yard.

### 2.9.2. Standards

- A. Where required, outdoor amenity space must be provided for each dwelling unit.
  - 1. Each outdoor amenity space must provide an unobstructed area of at least 24 square feet that may be used for seating.
  - 2. Some building types may allow outdoor amenity spaces to be shared spaces, provided that the shared space(s) includes the required area for each dwelling unit that the shared space is meant to serve. On building type pages this is indicated by the phrase “may be shared.”
  - 3. For all other building types, each outdoor amenity space must be directly accessible by a doorway from the dwelling unit it is meant to serve.

## Sec. 2.10. Public Gathering Space

### 2.10.1. Definition

A space for public use constructed as part of certain building types and multi-building assemblages.

### 2.10.2. Standards

- A. Space must be at least 1000 sf in size and may consist of plazas, greens, playgrounds, and other recreational areas.
- B. Space must be made available to the public from the hours of 8am-9pm at **the minimum**.
- C. Property owner will be responsible for maintaining the public gathering space in accordance with the approved plan.