

# 16 Crehore Dr, Newton Lower Falls

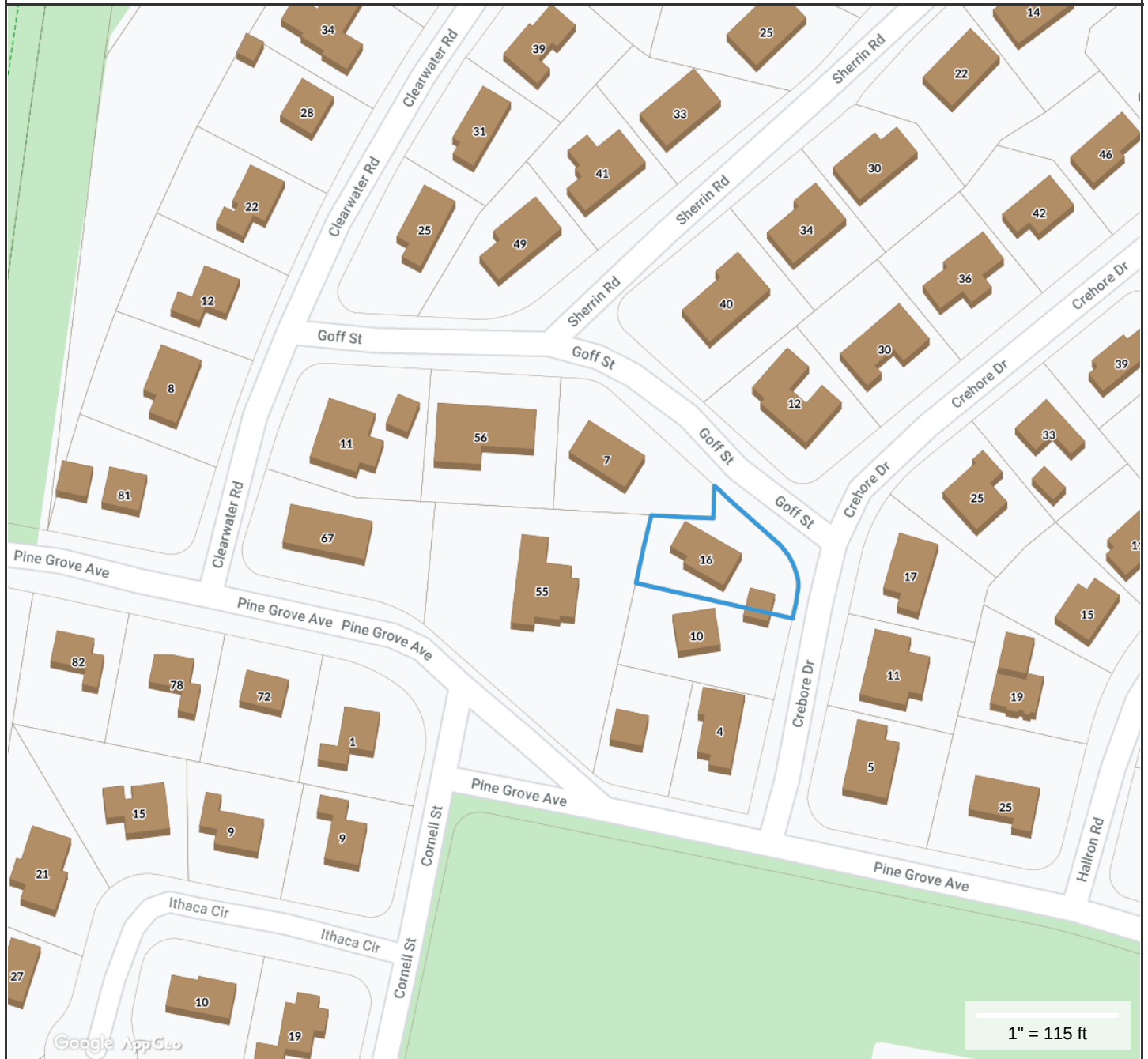

**Property Information**

**Property ID** 42020 0006  
**Location** 16 CREHORE DR  
**Owner** BIALEK ANDERS & HILARY



**MAP FOR REFERENCE ONLY  
NOT A LEGAL DOCUMENT**

City of Newton, MA makes no claims and no warranties, expressed or implied, concerning the validity or accuracy of the GIS data presented on this map.

Geometry updated 11/09/2018  
Data updated 11/14/2018

# ZONING LEGEND

ZONING DISTRICT: SINGLE RESIDENCE 3 (LOT CREATED AFTER 12/07/1953)				
	REQUIRED	EXISTING	COMPLIANCE	
MIN. AREA	10,000 S.F.	7,389± S.F.	EXISTING NON-COMFORMING	
MIN. FRONTAGE	80'	60.96'	EXISTING NON-COMFORMING	
MIN. YARD FRONT	30'	27.8'	EXISTING NON-COMFORMING	
	SIDE	10'	9.2'	EXISTING NON-COMFORMING
	REAR	15'	19.4'	YES
MAX. LOT COV.	30%	21.2%	YES	
MIN. OPEN SPACE	50%	76.7%	YES	
MAX. BLDG. HEIGHT	36'	25'±	YES	
MAX. STORIES	2.5	2.0	YES	

**NOTES:**

1. INFORMATION SHOWN ON THIS PLAN IS THE RESULT OF A FIELD SURVEY PERFORMED BY PETER NOLAN & ASSOCIATES LLC AS OF 09-13-13.
2. DEED REFERENCE BOOK 53485 PAGE 576, MIDDLESEX SOUTH REGISTRY OF DEEDS.
3. THIS PLAN IS NOT INTENDED TO BE RECORDED.
4. ELEVATIONS SHOWN ARE ASSUMED DATUM.
5. OPTION "A" S.F.= 514.43± S.F.
6. OPTION "B" S.F.= 1128.82± S.F.

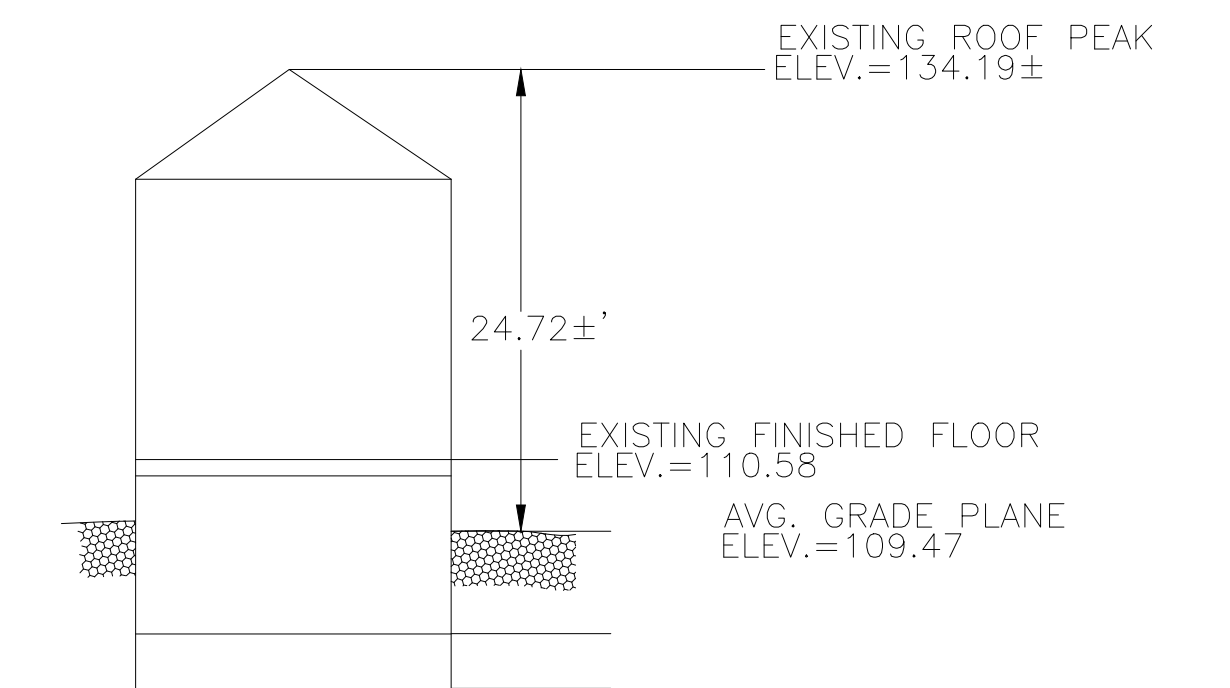

**EXISTING PROFILE**  
NOT TO SCALE

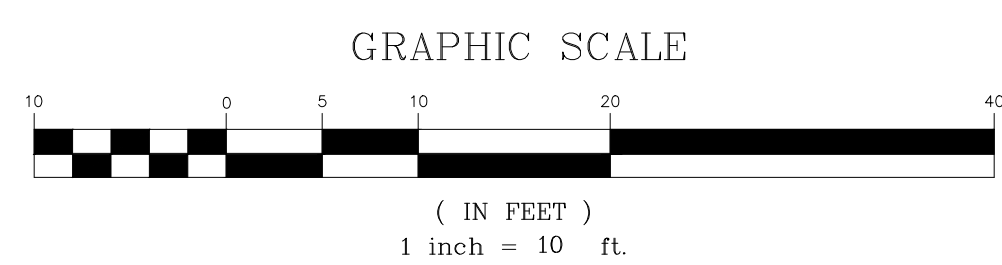
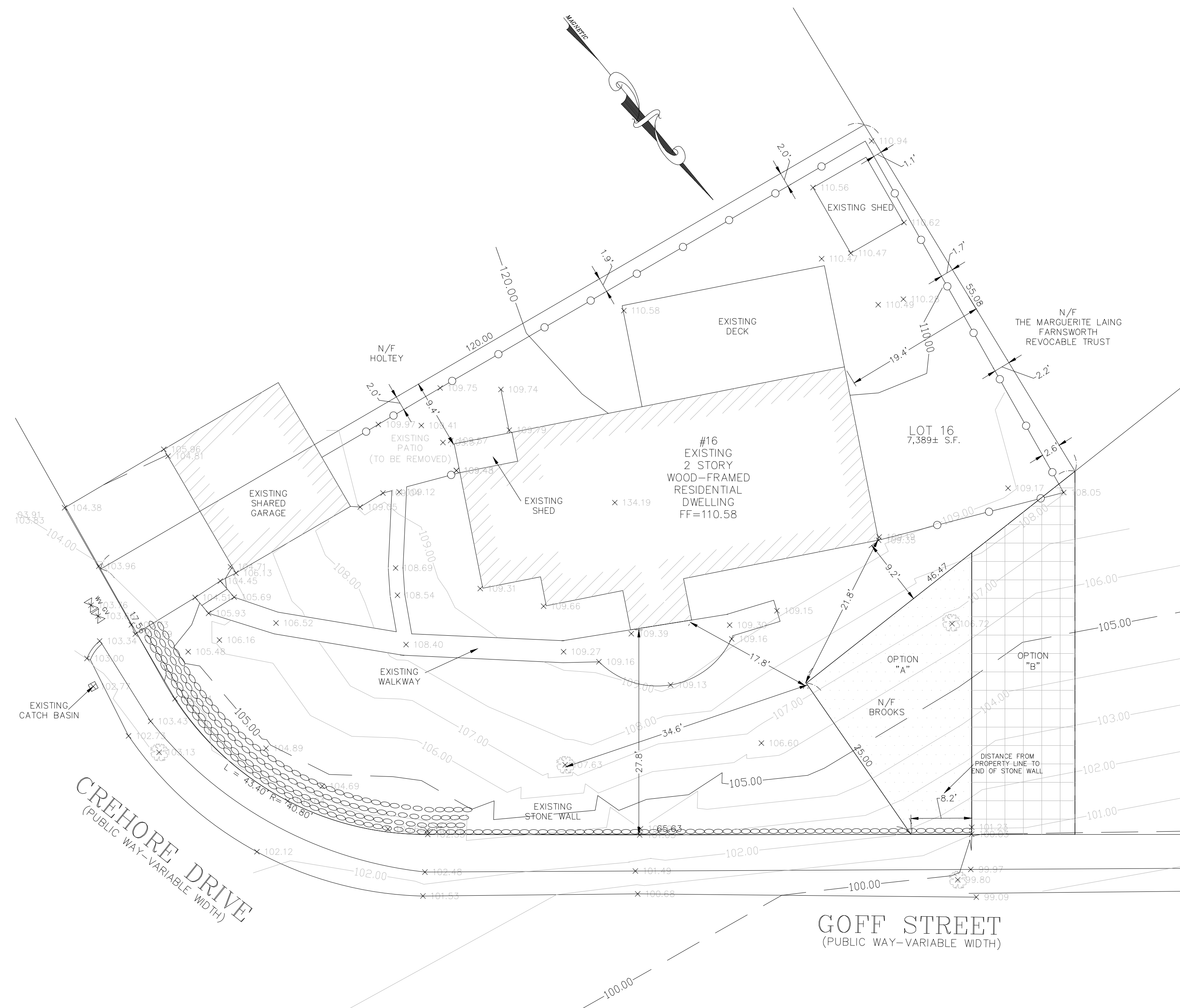

SCALE	1"=10'		
DATE	1/10/20	REV	DATE
SHEET	1	REVISION	BY
PLAN NO.	1 OF 1	16 CREHORE DRIVE NEWTON MASSACHUSETTS TOPOGRAPHY PLOT PLAN	
CLIENT:			
DRAWN BY	HILARY BIALEK		
CHKD BY	PJN		
APPD BY	PJN	PETER NOLAN & ASSOCIATES LLC LAND SURVEYORS/CIVIL ENGINEERING CONSULTANTS 697 CAMBRIDGE STREET, SUITE 103 BRIGHTON MA 02135 PHONE: 857 891 7478/617 782 1533 FAX: 617 202 5691 EMAIL: pnolan@pnasurveyors.com	
			SHEET NO. <b>1</b>

AVERAGE GRADE PLANE (ALL UNITS IN FEET)					
SEGMENT	LENGTH	POINT 1	POINT 2	MEAN 1 & 2	MEAN x LENGTH
1	13.90	108.40	109.40	108.90	1,513.71
2	54.00	109.70	110.40	110.05	5,942.70
3	24.00	110.20	108.90	109.55	2,629.20
4	25.90	108.30	109.40	108.85	2,819.22
5	10.10	109.10	109.10	109.10	1,101.91
6	31.90	109.40	107.20	108.30	3,454.77
7	20.00	107.20	106.90	107.05	2,141.00
SUM =	179.80				19,602.51
SUM OF MEAN x LENGTH/ SUM OF LENGTHS = AVERAGE GRADE PLANE =					<b>109.02</b>

ZONING LEGEND		
ZONING DISTRICT: SINGLE RESIDENCE 3 (LOT CREATED BEFORE 12/07/1953)		
	REQUIRED	PROPOSED
MIN. AREA	7,000 S.F.	7,389± S.F.
MIN. FRONTAGE	70'	60.96'
MIN. YARD FRONT	25'	27.7'
SIDE	7.5'	9.2'
	15'	8.7'
MAX. LOT COV.	30%	22.6%
MIN. OPEN SPACE	50%	69.4%
MAX. BLDG. HEIGHT	36'	24.56'±
MAX. STORIES	2.5	2.0

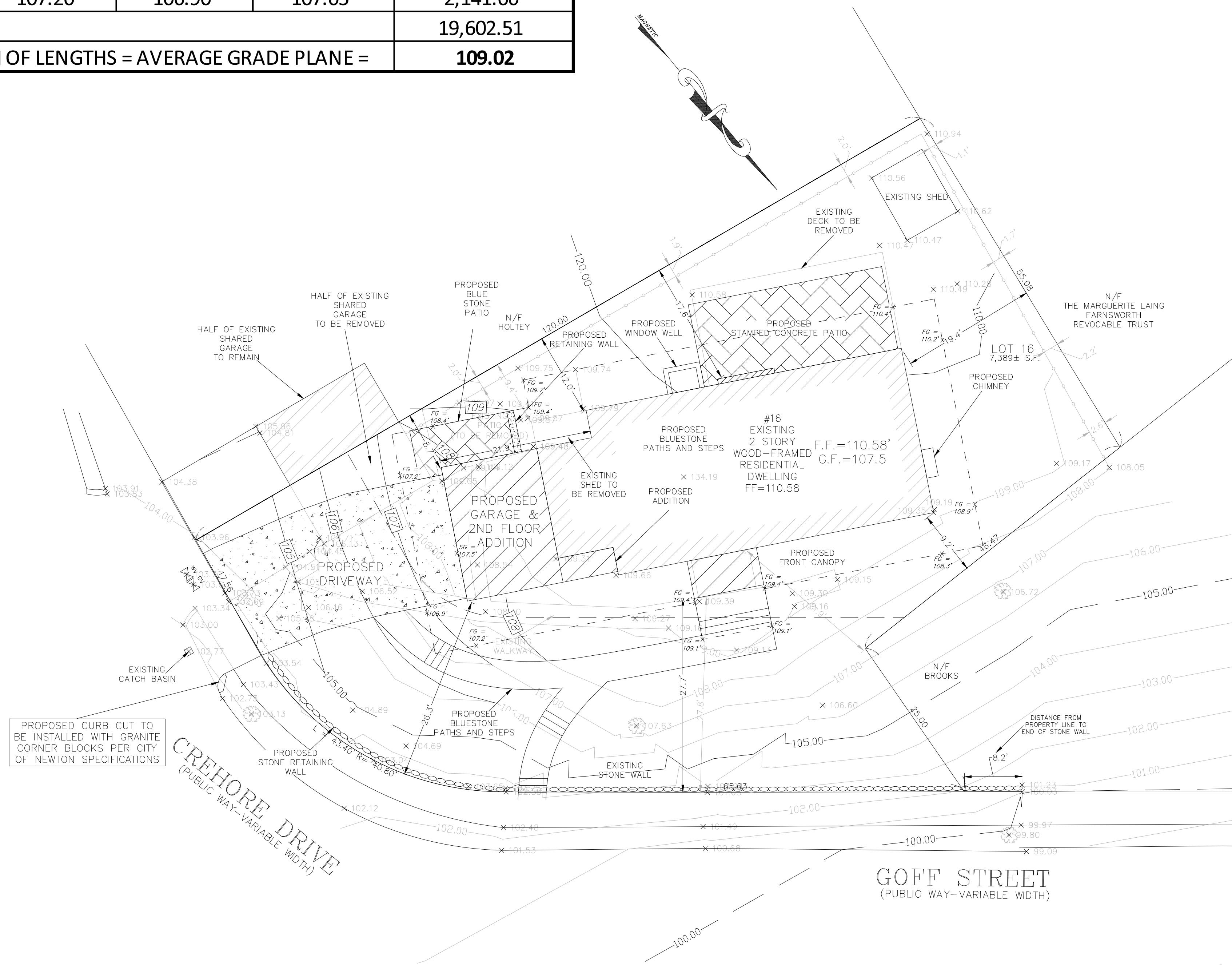

NOTES:

1. INFORMATION SHOWN ON THIS PLAN IS THE RESULT OF A FIELD SURVEY PERFORMED BY PETER NOLAN & ASSOCIATES LLC AS OF 09-13-13.
2. DEED REFERENCE BOOK 53485 PAGE 576, MIDDLESEX SOUTH REGISTRY OF DEEDS.
3. THIS PLAN IS NOT INTENDED TO BE RECORDED.
4. ELEVATIONS SHOWN ARE ASSUMED DATUM.

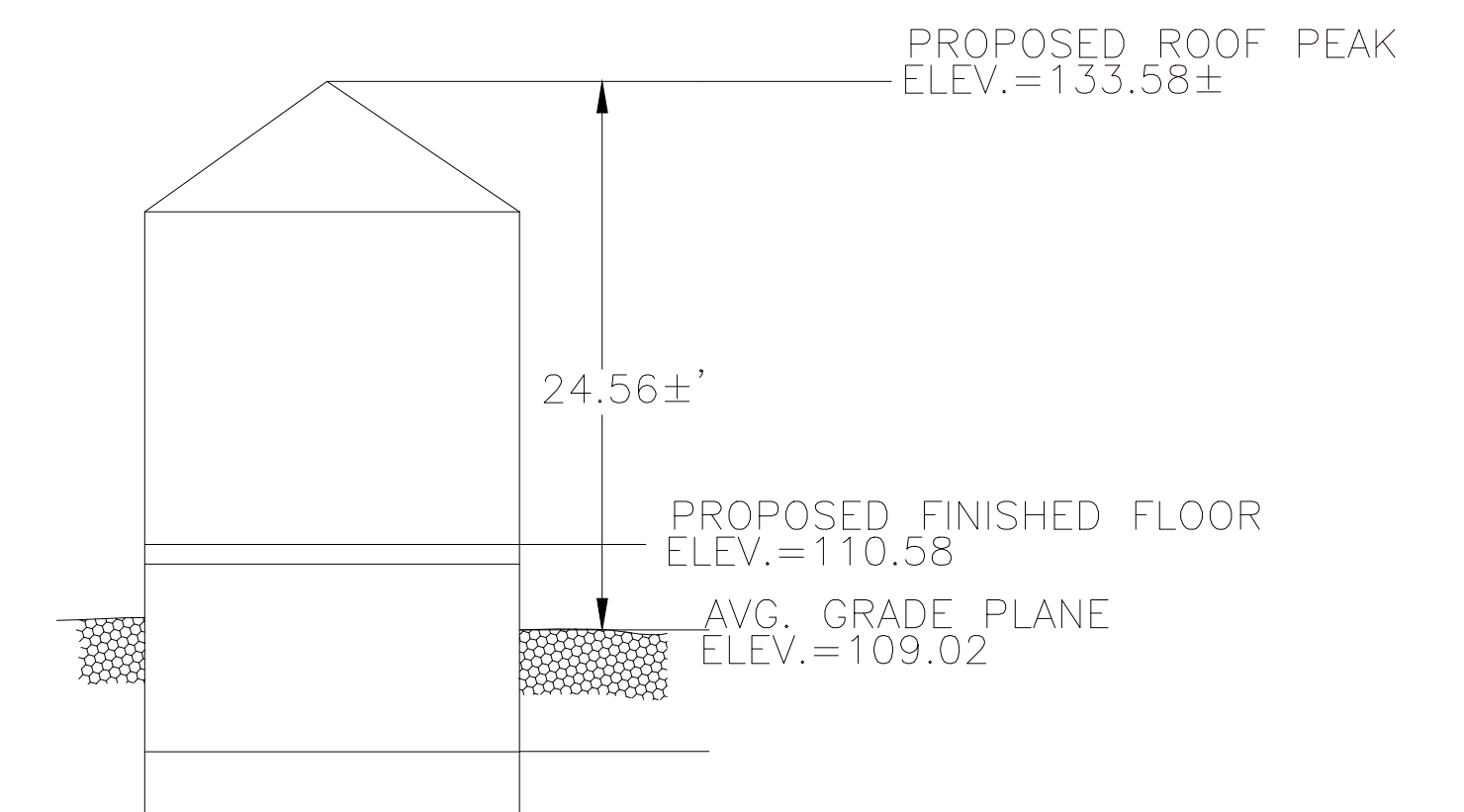

**PROPOSED PROFILE**  
NOT TO SCALE

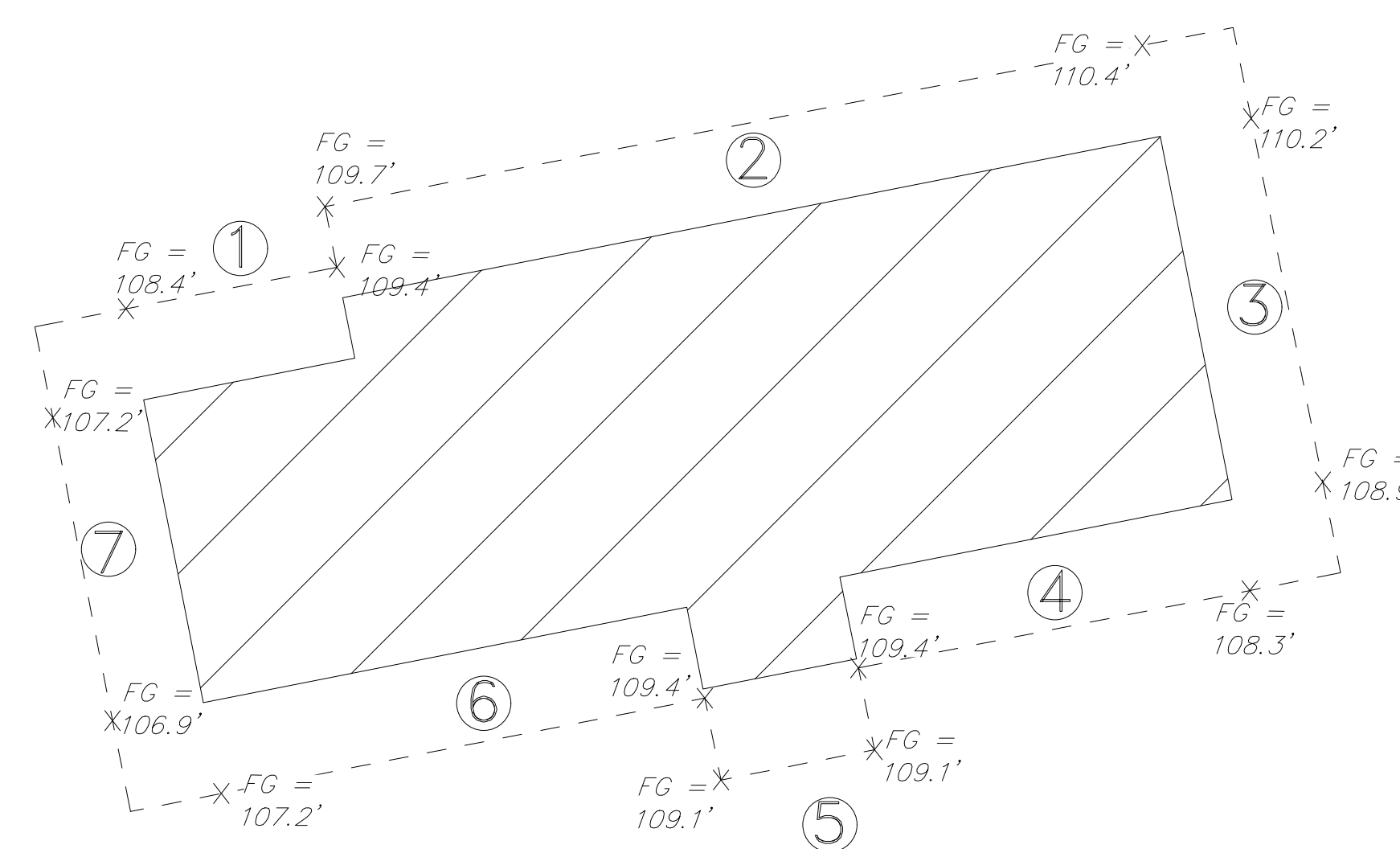
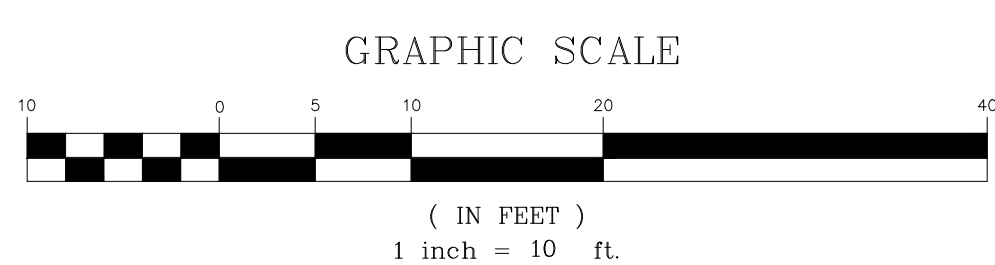

SCALE	1"=10'		
DATE	1/13/20	REV	DATE
SHEET	1	REVISION	BY
PLAN NO.	1 OF 1	16 CREHORE DRIVE NEWTON MASSACHUSETTS	
CLIENT:	HILARY BIALEK	PROPOSED PLOT PLAN	
DRAWN BY	HM	PETER NOLAN & ASSOCIATES LLC LAND SURVEYORS/CIVIL ENGINEERING CONSULTANTS	
CHKD BY	PJN	697 CAMBRIDGE STREET, SUITE 103 BRIGHTON MA 02135	
APPD BY	PJN	PHONE: 857 891 7478/617 782 1533 FAX: 617 202 5691	
		EMAIL: pnolan@pnasurveyors.com	

SHEET NO. **1**