



POSTED
City Clerk

Finance Committee Agenda

City of Newton In City Council

RECEIVED
By ssullivan at 2:43 pm, May 18, 2017

Monday, May 22, 2017

7 PM
Room 211

Items Scheduled for Discussion:

#141-17 Claim Settlement for damage from snow clearing
HIS HONOR THE MAYOR requesting authorization to appropriate ten thousand five hundred forty-seven dollars and twenty-five cents (\$10,547.25) from the Law Department's Legal Claims/Settlements Account for full and final settlement of claim against the City resulting from damage to a storefront during snow clearing operations. [05/08/17 @ 6:50 PM]

NOTE: The Committee will meet jointly with the Public Facilities Committee to discuss the below item:

Referred to Public Facilities and Finance Committees

#144-17 Request to bond \$2.7 million for water main improvements
HIS HONOR THE MAYOR requesting authorization to appropriate the sum of two million seven hundred thousand dollars (\$2,700,000) from bonded indebtedness for the purpose of providing additional funding for the continuation of the implementation of the City's Water Main Improvement Plan. [05/08/17 @ 6:49 PM]

NOTE: The Committee will meet jointly with the Public Facilities Committee to discuss the below item:

Referred to Public Facilities and Finance Committees

#145-17 Request to bond \$2.6 million for repair of a portion of the Laundry Brook culvert
HIS HONOR THE MAYOR requesting authorization to appropriate the sum of two million six hundred thousand dollars (\$2,600,000) from bonded indebtedness for the purpose of funding the removal and replacement of the Laundry Brook culvert adjacent to the proposed Cabot School. [05/08/17 @ 6:49 PM]

#142-17 Funding for a Public Information Plan for site clean-up at the Horace Mann School
HIS HONOR THE MAYOR requesting authorization to transfer the sum of fifteen thousand dollars (\$15,000) from the following accounts to the Public Building Department for the development of a public information plan regarding the site clean-

The location of this meeting is accessible and reasonable accommodations will be provided to persons with disabilities who require assistance. If you need a reasonable accommodation, please contact the city of Newton's ADA Coordinator, Jini Fairley, at least two business days in advance of the meeting: jfairley@newtonma.gov or (617) 796-1253. The city's TTY/TDD direct line is: 617-796-1089. For the Telecommunications Relay Service (TRS), please dial 711.

up at the Horace Mann School for an oil leak that occurred in 1998. [05/08/17 @ 6:49 PM]

Comptroller Wage & Salary Reserve (0110498-5197)	\$5,375
Comptroller Budget Reserve (0110498-5790)	\$3,810
Free Cash (01-3497)	\$5,815

#143-17 Acceptance of a \$22,400 MEMA Grant

HIS HONOR THE MAYOR requesting authorization to accept and expend the sum of twenty-two thousand four hundred dollars (\$22,400) from a Massachusetts Emergency Management Grant for the purpose of purchasing equipment and related items for the new Emergency Operations Center. [05/08/17 @ 6:49 PM]

Referred to Zoning & Planning and Finance Committees

#89-17 Transfer of \$125,000 to create a citywide economic development strategy

HIS HONOR THE MAYOR requesting authorization to transfer the sum of seventy-five thousand dollars (\$75,000) from the Planning Department Full-time Salaries Account and fifty thousand dollars (\$50,000) from the Economic Development Full-time Salaries Account to a specific project account to be established for the purpose of funding the creation of a citywide economic development strategy. [03/27/17 @2:20 PM]

Referred to Programs & Services, Public Facilities and Finance Committees

#387-16 Appropriate \$250,000 for renovation of 1st Floor of the Ed Center

HIS HONOR THE MAYOR requesting authorization to appropriate and expend two hundred fifty thousand dollars (\$250,000) from the Override Capital Stabilization Fund for the purpose of renovating the space on the 1st floor of the Ed Center which has been vacated by the relocation of the Pre-K Program to the Aquinas site to house the Central High School Program, additional professional development meeting space, and general office space. [10/31/16 @ 2:05 PM]

Programs & Services Approved 4-0 on 11/09/16

Public Facilities Held on 11/09/16

Items Not Scheduled for Discussion at this Meeting:

Referred to Land Use and Finance Committees

#122-17 Discussion on fees for Special Permits

COUNCILOR COTE requesting a discussion with the Planning & Development Department regarding the fees charged for Special Permits and what the actual costs are for issuing Special Permits. [04-18-17 @ 12:32 PM]

Referred to Public Facilities and Finance Committees

#123-17 **Pilot Program for curbside food waste collection**
COUNCILORS SANGIOLO, NORTON, CROSSLEY, LENNON, AUCHINCLOSS, HARNEY, FULLER, ALBRIGHT, LAPPIN, AND LAREDO requesting the City through the Department of Public Works, pilot a curbside food waste collection program. [04/21/17 @ 11:15 AM]

#110-17 **Appropriate \$2 million from Free Cash to the Rainy Day Stabilization Fund**
HIS HONOR THE MAYOR requesting authorization to appropriate two million dollars (\$2,000,000) from Free Cash to the Rainy Day Stabilization Fund. [04/12/17 @ 9:37 PM]

Referred to Public Facilities and Finance Committees

#91-17 **Licensing agreement for wireless carriers to install equipment on city poles**
COUNCILORS CROSSLEY, ALBRIGHT AND LAPPIN requesting a discussion with the administration regarding possible licensing agreements with wireless carriers, and to create a policy and to develop and adopt a uniform license agreement for wireless carriers to install wireless communication devices on city-owned poles in the public way. [03/27/17 @ 4:44 PM]

Referred to PS&T, Prog & Serv, Public Facilities and Finance Committees

#59-17 **Appropriate \$350,000 for construction of a Parks & Recreation/Police building**
HIS HONOR THE MAYOR requesting authorization to appropriate three hundred fifty thousand dollars (\$350,000) from Overlay Surplus for the purpose of funding the construction of a new combined Parks & Recreation and Police Department facility to be located at the Elliot Street DPW yard. [02-17-17 @ 9:29 AM]

Referred to Public Facilities and Finance Committees

#56-17 **Request to increase the Public Works Department by one full-time position**
HIS HONOR THE MAYOR requesting authorization to add one full-time employee within the Public Works Department to manage all detail requests submitted to the Police Detail Coordinator. [02/27/17 @ 2:42 PM]

Referred to Public Facilities and Finance Committees

#6-17 **Request to establish filing fee for wireless attachments in the public way**
COUNCILORS CROSSLEY, ALBRIGHT, LAPPIN AND GENTILE requesting the establishment of a filing fee from petitioners seeking to attach wireless communications devices to existing or proposed structures in the public way. [12/23/2016 @ 8:37 AM]
Public Facilities Approved 6-0 and referred the item to Finance

Referred to Zoning & Planning and Finance Committees

#444-16 **Amendment add fines for certain violations of the Accessory Apartment Ord.**
COUNCILOR BAKER AND COMMISSIONER OF INSPECTIONAL SERVICES proposing an amendment to Chapter 20 of the City of Newton Revised Ordinances to allow non-criminal ticketing of certain violations of the Accessory Apartment Ordinance. [12/16/16 @ 1:40 PM]

#397-16 **Discussion w School Administration re \$1.2 million budget deficit**
COUNCILOR GENTILE requesting a discussion with the School Department and members of the School Committee regarding the \$1.2 million deficit in the School Department budget as outlined in the 2017 Fiscal and Operational Update Memo dated October 24, 2016. [11/16/16 @ 10:48 AM]

Referred to Public Facilities and Finance Committees

#385-16 **Discussion about the Community Solar Share Program**
PUBLIC FACILITIES COMMITTEE requesting discussion with the Administration and Public Buildings Department about the Community Solar Share Program, which intends to provide credits resulting from solar power generated at 70 Elliot Street to qualifying low income residents. [10/26/16 @ 4:20 PM]
Public Facilities Held on 11/09/16

Referred to Public Facilities and Finance Committees

#384-16 **Appropriate \$71,000 to build an observation deck on the greenway**
HIS HONOR THE MAYOR requesting authorization to appropriate and expend seventy-one thousand dollars (\$71,000) from Free Cash for the purpose of construction an observation on the greenway walking corridor. [10/31/16 @ 2:05 PM]
Public Facilities Held on 11/09/16

Referred to Finance and Appropriate Committees

#359-16 **Submittal of the FY 2018 to FY 2021 Capital Improvement Plan**
HIS HONOR THE MAYOR submitting the Fiscal Years 2018 to 2022 Capital Improvement Plan pursuant to section 5-3 of the Newton City Charter. [10/11/16 @ 11:28 AM]

Referred to Public Facilities and Finance Committees

#357-16 **Reallocate \$250,467.24 for decommissioning two elevated storage tanks**
HIS HONOR THE MAYOR requesting authorization to reallocate the sum of two hundred fifty thousand four hundred sixty-seven dollars and twenty-four cents (\$250,467.24) from the Waban Hill Reservoir Improvements Account to be used for the decommissioning of the Stanton Avenue and Winchester Street elevated storage tanks. [10/11/16 @ 11:29 AM]
Public Facilities Approved 6-0 on 10/19/16

- #353-16 Review/Acceptance of the FY 2018 – FY 2022 5-year Financial Forecast**
HIS HONOR THE MAYOR submitting the Fiscal Years 2018 to 2022 5-Year Financial Forecast for City Council review/acceptance. [10/11/16 @ 11:28 AM]

Referred to Land Use, Programs & Services and Finance Committees

- #256-16 Request to extend notification area of notice for special permit petitions**
COUNCILORS COTE, NORTON, HARNEY, BLAZER, BROUSAL-GLASER, AND LEARY requesting an amendment to the City Council Rules, Article X; Section 6 – Additional Notification Requirements, to include that the area of notice for special permit petitions be expanded beyond the abutters to abutters within 300’ required by Massachusetts General Law Chapter 40A to also include property owners within 600’ of the subject property. This notification will apply to all classes of building except for residential 1 and 2-family units that will remain 1 or 2-family units after receiving a special permit. Only abutters to abutters within 300’ will be entitled to the rights conferred by Massachusetts General Law Chapter 40A. [07/01/16 @2:09 PM]
- #209-16 Discussion of expenditures related to the Complete Streets Grant**
COUNCILOR FULLER requesting discussion regarding expenditures related to the Complete Streets grant with representatives of the Department of Public Works. [05/26/16 @ 1:11 PM]
- #112-16 Appropriation of mitigation funds for pedestrian and traffic improvements**
HIS HONOR THE MAYOR requesting authorization to appropriate and expend the following Mitigation Funds:
- | | |
|--|----------|
| A. Village Café at 719 Washington Street | \$2,500 |
| B. 258 Nevada Street at Linwood Street | \$1,500 |
| C. Cherry Street at Washington Street | \$2,000 |
| D. O’Hara’s Restaurant, Newton Highlands | \$2,500 |
| E. Rox Diner Parking & Pedestrian Improvements | \$2,500 |
| G. Canton Circle LLC, 714-724 Beacon Street | \$10,000 |
- #40-16 Request to accept MGL 149 Sec 148C related to earned sick time for employees**
COUNCILOR SANGIOLO requesting that City of Newton formally accept and/or take all necessary steps to accept Massachusetts General Law Chapter 149, Section 148C, in order to qualify full-time, part-time, seasonal, and temporary employees coverage under the earned sick time regulation, 940 CMR 33, as approved by the voters of Massachusetts in the 2014 Election as Ballot Question 4 – Earned Sick Time for Employees. [01/19/16 @ 2:35 PM]

Referred to Public Facilities and Finance Committees

- #223-15** **Discussion on the process of licensing the use of city buildings**
ALD. LAREDO requesting a discussion of the process of licensing the current and future use of city building, including: (a) how licensees may request the use of city buildings; (b) the process for determining which licensees will get the use of city buildings; (c) how the fees for the use of city buildings are set; and (d) how the current process compares to the process for permitting the use of school buildings. [08/13/15 @ 11:20 AM]
- #190-15** **Discussion of policy to record all meetings and post meeting materials online**
ALD. SANGIOLO requesting a discussion with the Executive Department relative to creating a policy to require audio recordings of all meetings of boards and commissions and requiring them to be posted to the City's website, as well as posting of all documentation that is reviewed by boards and commissions and/or by their designated City staff member.

Referred to Zoning & Planning, Land Use and Finance Committees

- #104-15** **Qualification of affordable units developed at Comm Ave, Pearl St, and Eddy St**
ALD. JOHNSON, LAREDO, AND GENTILE requesting a report from the Planning Department re how many of the affordable units developed at Commonwealth Avenue, Pearl Street, and Eddy Street qualify for inclusion on the State's Subsidized Housing Inventory List; if a property is not on the list, what can be done to make it eligible. [04/09/15 @ 12:00 PM]

Referred to Land Use and Finance Committees

- #49-14** **Implementation of technology to monitor compliance with special permits**
LAND USE COMMITTEE requesting discussion with the Chief Financial Officer and the Chief Information Officer regarding the critical need to implement technology which enables the development, management and use of shared, searchable, mobile-accessed (both read and write) database which contains parcel-based information that can be accessed by all city departments (including Planning, Inspectional Services (ISD), Assessing, Engineering, Fire, Police, Health), the Board of Aldermen and the community. This technology must support the work of ISD and other departments in both the office and the field to more effectively and efficiently monitor and enforce compliance with approved special permits and other related Board Orders. [02/10/14 @ 6:47 PM]

Respectfully submitted;

Leonard J. Gentile, Chair



SETTI D. WARREN
MAYOR

City of Newton, Massachusetts
Office of the Mayor

#141-17

Telephone
(617) 796-1100

Telefax
(617) 796-1113

TDD
(617) 796-1089

E-mail
swarren@newtonma.gov

May 8, 2017

Honorable City Council
Newton City Hall
1000 Commonwealth Avenue
Newton Centre, MA 02459

Ladies and Gentlemen:

I write to request that your Honorable Board docket for consideration a request to authorize the appropriation of \$10,547.25 from Acct # 0110893-5725 Law Department Legal Claims/Settlements for full and final settlement of Claim # 17-125.

This claim was filed against the City for extensive damage to a storefront that occurred during snow clearing operations. Thank you for your consideration of this matter.

Sincerely,

Setti D. Warren
Mayor

RECEIVED
Newton City Clerk
2017 MAY -8 PM 6:50
David A. Olson, CMC
Newton, MA 02459



SETTI D. WARREN
MAYOR

City of Newton, Massachusetts
Office of the Mayor

#144-17

Telephone
(617) 796-1100

Telefax
(617) 796-1113

TDD
(617) 796-1089

E-mail
swarren@newtonma.gov

May 8, 2017

Honorable City Council
Newton City Hall
1000 Commonwealth Avenue
Newton Centre, MA 02459

Ladies and Gentlemen:

I write to request that your Honorable Board docket for consideration a request to authorize the appropriation of the sum of \$2,700,000 and authorize a general obligation borrowing of an equal amount for the purpose of providing additional funding for the continuation of the implementation of the City's Water Main Improvement Plan.

Thank you for your consideration of this matter.

Sincerely,

Setti D. Warren
Mayor

RECEIVED
Newton City Clerk
2017 MAY -8 PM 6:49
David A. Olson, CMC
Newton, MA 02459

**Year Two Improvements 2017
Newton, Massachusetts**

144-17

Improvement No.	CDM Improvement No.	Street Name	From	To	Existing Diameter (inches)	Proposed Diameter (inches)	Length (ft)	Estimated Cost
21	189	Garland Road	Homer Street	Beacon Street	6,8	8	1,800	\$ 315,000
22	140	Cook Street	Watertown Street	Green Street	6	8	1,000	\$ 175,000
23	215	Hovey Street	Washington Street	Waban Street	6	8	500	\$ 88,000
25	12	Van Roosen Road	Saw Mill Brook Pkway	Wiswall Road	8	8	900	\$ 158,000
26	23	Mechanic Street	Chestnut St	Dead End	6	8	800	\$ 140,000
28	77	Parkview Avenue	Norwood Avenue	Cabot Street	6	8	800	\$ 140,000
29	115	Phillips Street	Bourne Street	Commonwealth Ave	6	8	400	\$ 70,000
30	158	Washburn Street	Pearl Street	Watertown Town Line	6	8	800	\$ 140,000
31	174	Ricker Road	Tremont Street	Arlington Street	6	8	600	\$ 105,000
33	224	Wiswall Street	Parsons Street	Cross Street	6	8	400	\$ 70,000
34	244	Margaret Road	Elliot Street	Boylston Street	6	8	1,000	\$ 175,000
35	405	Lindbergh Avenue	Waltham Street	Princess Road	6	8	1,000	\$ 175,000
36	6	Rowe Street	Crescent Street	Commonwealth Ave	6	8	1,700	\$ 298,000
38	154	Hilltop Street/Princeton Street	Lewis Street	East Side Parkway	6	8	900	\$ 158,000
39	371	Upland Avenue	Dedham Street	Rachel Road	8	8	3,800	\$ 665,000
40	207	Rochester Road	Westchester Road	Dead End	6	8	700	\$ 123,000
43	233	Propsect Street	Washington Street	Curve Street	6	8	500	\$ 88,000
44	284	Kimball Terrace	Otis Street	End of 4"	4	8	400	\$ 70,000
10	289	Belmont Street	Tremont Street	Arlington Street	4	8	500	\$ 88,000
17	17	Harding St/Kensington Ave	Crafts Street	High Street	8 and 6	8	2,200	\$ 385,000
		Boylston St ramp EB Rt 9	Chestnut St	High Street	6	8	350	\$ 61,000
		Willow St	Centre St	Sumner St	6	8	700	\$ 123,000

Total \$ 3,810,000



SETTI D. WARREN
MAYOR

City of Newton, Massachusetts
Office of the Mayor

#145-17

Telephone
(617) 796-1100

Telefax
(617) 796-1113

TDD
(617) 796-1089

E-mail
swarren@newtonma.gov

May 8, 2017

Honorable City Council
Newton City Hall
1000 Commonwealth Avenue
Newton Centre, MA 02459

RECEIVED
Newton City Clerk
2017 MAY -8 PM 6:49
David A. Olson, OMC
Newton, MA 02459

Ladies and Gentlemen:

I write to request that your Honorable Board docket for consideration a request to authorize the appropriation of the sum of \$2,600,000 and authorize a general obligation borrowing of an equal amount for the removal and replacement of the Laundry Brook culvert adjacent to the proposed Cabot School due to increasing structural failure of the culvert.

Thank you for your consideration of this matter.

Sincerely,

Setti D. Warren
Mayor

1.0 - GENERAL

- 1.01 THE STRUCTURAL DRAWINGS SHALL BE USED IN CONJUNCTION WITH ALL OTHER CONTRACT DRAWINGS AND SPECIFICATIONS. REFER TO CIVIL, ARCHITECTURAL, MECHANICAL, PLUMBING, AND ELECTRICAL DRAWINGS FOR LOCATION, DIMENSIONS, AND DETAILS OF OPENINGS, SLEEVES, EMBEDMENTS, INSERTS, PADS, CURBS, DEPRESSIONS, ANCHOR BOLTS, AND OTHER PROJECT REQUIREMENTS NOT SHOWN ON STRUCTURAL DRAWINGS.
1.02 THE CONTRACTOR IS RESPONSIBLE FOR CHECKING, COORDINATING AND VERIFYING ALL DIMENSIONS IN THE FIELD PRIOR TO COMMENCING WORK. THE CONTRACTOR SHALL IMMEDIATELY REPORT ANY DISCREPANCY TO THE ARCHITECT AND ENGINEER AS A REQUEST FOR INFORMATION (RFI) BEFORE PROCEEDING WITH WORK.
1.03 THE CONTRACTOR IS RESPONSIBLE FOR VERIFYING IN THE FIELD THE EXISTENCE AND LOCATION OF OVERHEAD, BURIED AND/OR EMBEDDED UTILITIES, AND DETERMINING LOCATIONS OF ALL EMBEDDED MECHANICAL, ELECTRICAL AND PLUMBING SYSTEMS AFFECTED BY THE WORK OF THIS CONTRACT.
1.04 ALL WORK IS TO CONFORM WITH CODES AND STANDARDS REFERENCED IN THE SPECIFICATIONS.
1.05 THE CONTRACTOR SHALL NOTIFY THE ENGINEER OF UNFORSEEN CONDITIONS THAT MAY BE UNCOVERED DURING CONSTRUCTION AS A REQUEST FOR INFORMATION (RFI) BEFORE PROCEEDING WITH WORK.
1.08 DETAILS AND NOTES SHOWN ON STRUCTURAL DRAWINGS SHALL BE APPLICABLE TO ALL PARTS OF THE STRUCTURAL WORK EXCEPT WHERE SPECIFICALLY REQUIRED OTHERWISE BY CONTRACT DOCUMENTS, CONDITIONS NOT SPECIFICALLY SHOWN SHALL BE SIMILAR TO THOSE SHOWN FOR LIKE CONDITIONS AS DETERMINED BY THE ENGINEER.
1.09 TESTING AND INSPECTION OF STRUCTURAL WORK SHALL BE THE RESPONSIBILITY OF THE CONTRACTOR. THE COSTS FOR TESTING AND INSPECTION WILL BE PAID BY THE CONTRACTOR. FOR ADDITIONAL INFORMATION CONCERNING TESTING AND INSPECTION, REFER TO SECTION 01450 OF THE TECHNICAL SPECIFICATIONS.
1.10 THE CONTRACTOR SHALL DESIGN AND PROVIDE ALL REQUIRED SHORING AND TEMPORARY BRACING TO RESIST FORCES ON THE STRUCTURE THROUGHOUT THE CONSTRUCTION PERIOD.
1.12 SUBMIT SHOP DRAWINGS, WITH AMPLE TIME FOR ENGINEER'S REVIEW AND APPROVAL, FOR STRUCTURAL ELEMENTS, INCLUDING STRUCTURAL STEEL AND PRECAST CONCRETE.

- (B) CONCRETE EXPOSED TO EARTH OR WEATHER:
(1) NO. 6 THRU NO. 18 BARS 2"
(2) NO. 5 BAR, W31 OR D31 WIRE AND SMALLER 1 1/2"
(C) SURFACES NOT EXPOSED TO WEATHER OR IN CONTACT WITH GROUND:
(1) SLABS, WALLS, JOISTS:
(a) NO. 14 AND NO 18 BARS 1 1/2"
(b) NO. 11 BARS AND SMALLER 1"
(2) BEAMS, COLUMNS:
(a) PRIMARY REINFORCEMENT, TIES, STIRRUPS, SPIRALS 1 1/2"
(3) SHELLS, FOLDED PLATE MEMBERS:
(a) NO. 6 BARS AND LARGER 3/4"
(b) NO 5 BAR, W31 OR D31 WIRE AND SMALLER 1/2"

- 5.05 REINFORCING STEEL SHALL BE CONTINUOUS THROUGH ALL CONSTRUCTION JOINTS, CORNERS, AND INTERSECTIONS UNLESS OTHERWISE NOTED. REINFORCING SHALL BE LAPPED AT NECESSARY SPLICES OR HOOKED AT DISCONTINUOUS ENDS, UNLESS OTHERWISE NOTED.
5.06 FOR REINFORCING STEEL SPLICE LAP LENGTHS REFER TO THE TABLE PROVIDED UNLESS OTHERWISE INDICATED.
5.07 MECHANICAL SPLICES SHALL BE PERMITTED SUBJECT TO APPROVAL BY THE ENGINEER. MECHANICAL SPLICES SHALL DEVELOP AT LEAST 125 PERCENT OF THE SPECIFIED YIELD STRENGTH OF THE BAR, NO WELDED CONNECTIONS ARE PERMITTED.
5.08 WELDED WIRE FABRIC SHALL BE LAPPED (1) SQUARE PLUS (2) INCHES WHERE REQUIRED AND SHALL BE WIRED TOGETHER AT ALL LAPS. WWF SHALL BE SUPPORTED BY CHAIRS AND/OR CARRYING BARS PRIOR TO CONCRETE PLACEMENT.
5.09 REINFORCEMENT SHALL NOT BE TACK WELDED.
5.10 NOTIFY THE TESTING LAB AND ENGINEER A MINIMUM OF 48 HOURS PRIOR TO SCHEDULED CONCRETE PLACEMENT IN ORDER TO ACCOMMODATE INSPECTION OF REINFORCEMENT AND CONCRETE TESTING. NO CONCRETE SHALL BE PLACED WITHIN 48 HOURS OF SUCH NOTIFICATION.
5.11 WHERE REINFORCEMENT IS NOT SHOWN ON DRAWINGS, PROVIDE REINFORCEMENT IN ACCORDANCE WITH APPLICABLE DETAILS AS DETERMINED BY THE ARCHITECT AND ENGINEER. IN NO CASE SHALL REINFORCEMENT BE LESS THAN THE MINIMUM REINFORCEMENT PERMITTED BY THE CODES, NOR LESS THAN THE FOLLOWING:
(A) BEAM STIRRUPS: #3 @12"
(B) BEAM STIRRUP SUPPORTS: 1-#5 AT EACH STIRRUP BEND
(C) FACE REINFORCEMENT IN BEAMS OR PORTIONS OF BEAMS #4@12" EF.
(D) STRUCTURAL SLABS: .0020 GROSS CONCRETE AREA IN EACH DIRECTION
(E) CONCRETE WALLS: .0025 x GROSS CONCRETE AREA IN EACH DIRECTION
5.12 WHERE REINFORCEMENT IS REQUIRED IN SECTION, REINFORCEMENT IS CONSIDERED TYPICAL WHEREVER THE SECTIONS APPLIES.
5.13 WHERE THERE IS CONFLICT BETWEEN LOCATIONS OF COLUMN VERTICAL BARS AND BEAM HORIZONTAL BARS, THE COLUMN BARS SHALL REMAIN IN THEIR DESIGNATED POSITIONS AND BEAM BAR LOCATIONS SHALL BE ADJUSTED.
5.14 DOWELS SHALL MATCH BAR SIZE, NUMBER AND SPACING, UNLESS NOTED OTHERWISE.

2.0 DESIGN LOADS

- 2.01 CULVERT SHALL BE DESIGNED IN ACCORDANCE WITH THE 2014 AMERICAN ASSOCIATION OF HIGHWAY AND TRANSPORTATION OFFICIALS (AASHTO) LRFD BRIDGE DESIGN SPECIFICATIONS WITH CURRENT INTERIM SPECIFICATIONS THROUGH 2016, FOR HL-93 LOADING.
2.06 GEOTECHNICAL INFORMATION
(A) ALLOWABLE NET BEARING PRESSURE 3000 PSF**
SEE GEOTECHNICAL REPORT FOR ADDITIONAL DATA AND REQUIREMENTS
**BEARING PRESSURE IS ALLOWED TO BE INCREASED TO 6000 PSF FOR WIND OR SEISMIC LOADINGS PROVIDED LOAD ECCENTRICITIES REMAIN WITHIN THE MIDDLE 1/2 OF THE FOOTING.

3.0 - FOUNDATIONS

- 3.01 THE SUBSURFACE CONDITIONS DESCRIBED IN THE DRAWINGS, SPECIFICATIONS, TEST BORINGS AND TEST PITS ARE INCLUDED ONLY TO ASSIST THE CONTRACTOR DURING BIDDING AND SUBSEQUENT CONSTRUCTION AND REPRESENT CONDITIONS ONLY AT THESE SPECIFIC LOCATIONS AT THE TIME THEY ARE MADE.
3.02 THE CONTRACTOR SHALL DESIGN AND PROVIDE ALL TEMPORARY EARTH SUPPORT, SHORING AND BRACING REQUIRED TO PERFORM THE WORK IN ACCORDANCE WITH OSHA, STATE AND LOCAL REQUIREMENTS.
3.03 THE CONTRACTOR SHALL DESIGN AND PROVIDE SHEETING, SHORING, BRACING, AND/OR UNDERPINNING IN ORDER TO PROTECT EXISTING UTILITIES FROM EXCESSIVE MOVEMENTS DURING THE CONSTRUCTION PERIOD, IN ACCORDANCE WITH OSHA, STATE & LOCAL REQUIREMENTS.
3.04 THE CONTRACTOR SHALL CARRY OUT CONTINUOUS CONTROL OF SURFACE AND SUBSURFACE WATER, DEWATER ANY AREAS REQUIRING EXCAVATION IN ADVANCE OF PERFORMING EXCAVATION, MAINTAIN GROUNDWATER LEVELS AT LEAST 2 FEET BELOW PLANNED SUBGRADES.
3.05 ALL SUBGRADES TO RECEIVE FILL MATERIALS, FOUNDATIONS, SLABS OR OTHER CONSTRUCTION SHALL BE FREE OF RUNNING OR STANDING WATER PRIOR TO PLACEMENT.
3.07 FOUNDATIONS SHALL BE INSTALLED IN THE GEOMETRY SHOWN IN THE PLANS, ANY ROCK ENCOUNTERED DURING EXCAVATION SHALL BE REMOVED TO CLEAR THE REQUIRED FOUNDATION GEOMETRY.

4.0 - CAST IN PLACE CONCRETE

- 4.01 CONCRETE WORK SHALL CONFORM TO "BUILDING CODE REQUIREMENTS FOR REINFORCED CONCRETE" (ACI 318-02) AND "SPECIFICATIONS FOR STRUCTURAL CONCRETE FOR BUILDINGS" (ACI 301-99).
4.02 CONCRETE SHALL BE CONTROLLED CONCRETE, PROPORTIONED, MIXED AND PLACED IN THE PRESENCE OF A REPRESENTATIVE OF AN APPROVED TESTING AGENCY.
4.03 UNLESS NOTED OTHERWISE, CONCRETE SHALL BE NORMAL WEIGHT AND HAVE A MINIMUM 28 DAY COMPRESSIVE STRENGTH PF 4000 PSI.
4.04 ALL PERMANENTLY EXPOSED VERTICAL AND HORIZONTAL CONCRETE SURFACES SHALL BE TREATED OR SEALED IN ACCORDANCE WITH PROJECT SPECIFICATIONS.
4.08 A MINIMUM OF 72 HOURS SHALL ELAPSE BETWEEN ADJACENT CONCRETE PLACEMENTS.
4.10 PROVIDE A 1/2" CHAMFER ON ALL VERTICAL AND HORIZONTAL CORNERS EXPOSED TO VIEW UNLESS NOTED OTHERWISE.

5.0 - CAST IN PLACE CONCRETE REINFORCEMENT

- 5.01 REINFORCEMENT DETAILING, FABRICATION, AND ERECTION SHALL CONFORM TO "ACI DETAILING MANUAL" - SP-66, "CRSI MANUAL OF STANDARD PRACTICE".
5.02 STEEL REINFORCEMENT, UNLESS NOTED OTHERWISE, SHALL CONFORM TO THE FOLLOWING:
(A) BARS, TIES, AND STIRRUPS ASTM A615 GRADE 60
(B) WELDED WIRE FABRIC ASTM A185, FLAT SHEETS FOR FLOOR SLABS.
5.03 REINFORCING STEEL SHALL BE UNCOATED AND DEFORMED.
5.04 MINIMUM CONCRETE PROTECTIVE COVERING FOR REINFORCEMENT, UNLESS REQUIRED FOR FIRE PROTECTION OR NOTED OTHERWISE, SHALL BE AS FOLLOWS:
(A) CONCRETE CAST AGAINST AND PERMANENTLY EXPOSED TO EARTH: 3"

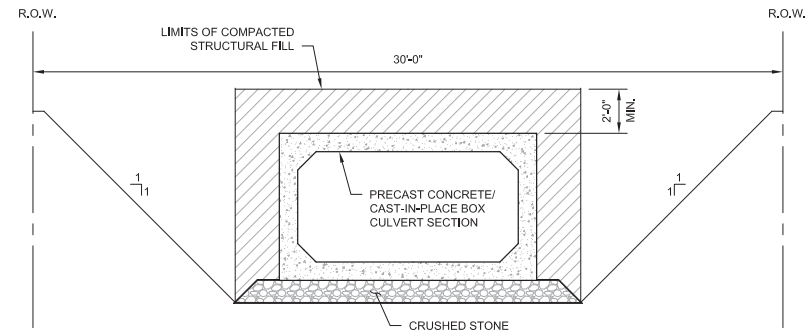

NOTE: 1. EXCAVATION SLOPE SHOULD MAINTAIN A 1 TO 1 SLOPE. TEMPORARY EARTH SUPPORT SHOULD BE USED IF 1 TO 1 SLOPE CANNOT BE MAINTAINED.
EXCAVATION/BACKFILL
SCALE: 1/4"=1'-0"

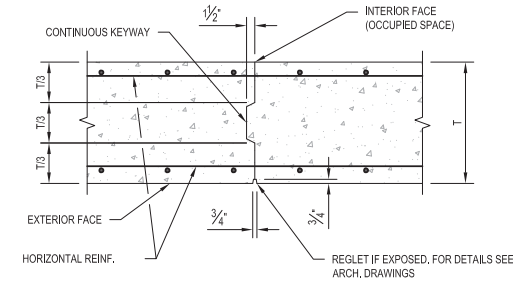

VERTICAL CONSTRUCTION JOINT

Table titled 'MINIMUM SPLICE AND EMBEDMENT LENGTH SCHEDULE' for Class B Tension Splice. It includes a table for Top Bars Category and Other Bars Category, with columns for bar size and length. The table is for fc = 4000 PSI Normal Weight and Fy = 60,000 PSI.

REINFORCING SPLICE SCHEDULE

FOR PERMITTING

Weston & Sampson Engineers, Inc.
Five Centennial Drive, Peabody, MA 01960
978.532.1900
www.westonandsampson.com

Table with columns for No., Date, App. By, Ck. By, Dr. By, Description, and Date. It is used for tracking design and approval stages.



CITY OF NEWTON, MASSACHUSETTS
DEPARTMENT OF PUBLIC WORKS
LAUNDRY BROOK CULVERT REPLACEMENT
GENERAL NOTES AND TYPICAL DETAILS
SCALE: NOTED
CONTRACT: 2160710
JOB NO. 2160710
DRBY C/JW
DSNBY C/JW
CHKBY SRB
APP.BY RAC

S-7
SHEET - OF -

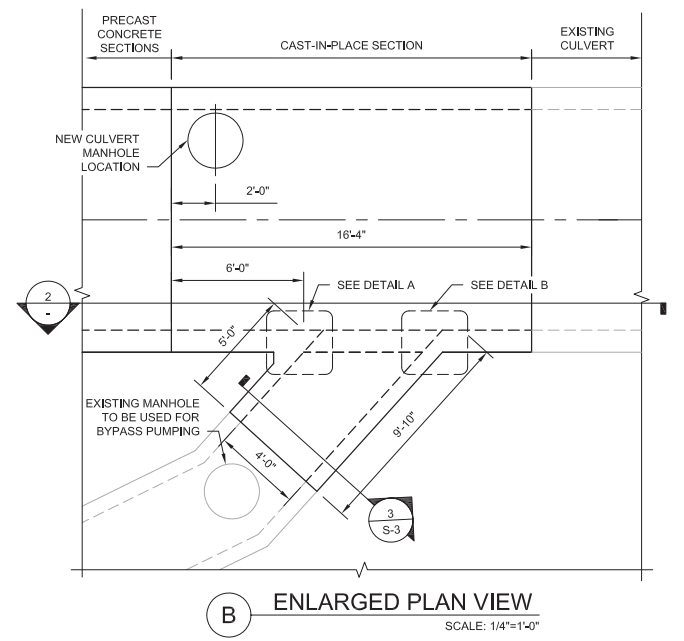
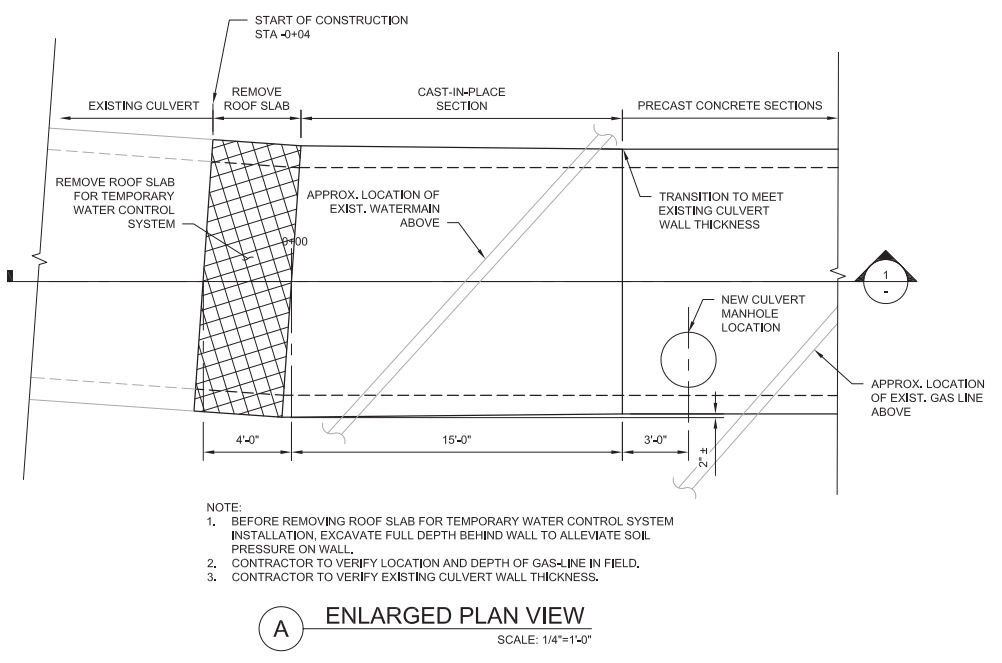
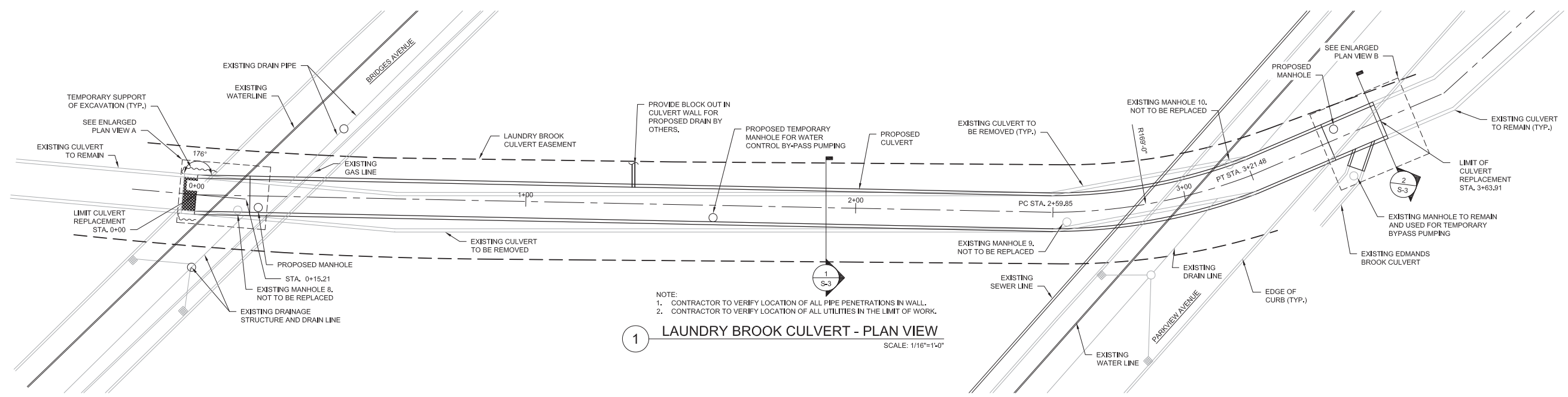

WATER CONTROL NOTES

1. THE CONTRACTOR SHALL DESIGN AND PROVIDE CONTROL OF ALL EXISTING FLOWS DURING THE CONSTRUCTION OF THE NEW CULVERT SECTION. THE CONTRACTOR SHALL SUBMIT TO THE ENGINEER THE PROPOSED MEANS AND METHODS TO CONTROL EXISTING FLOWS.
2. A 4'-0" LENGTH OF THE EXISTING CULVERT ROOF SLAB AT LIMITS OF THE CULVERT REPLACEMENT MAY BE REMOVED FOR INSTALLATION OF THE CONTRACTOR'S WATER CONTROL STRUCTURE FOR CONTROL OF EXISTING FLOWS. THE CULVERT ROOF SLABS SHALL BE REPLACED AS SHOWN ON THE PLANS AT THE COMPLETION OF THE CULVERT CONSTRUCTION.
3. THE EXISTING CULVERT SHALL BE SAW CUT AT THE LIMITS OF REPLACEMENT, THE DEPTH OF THE SAW CUT SHALL BE A MINIMUM OF 2'.
4. THE CURVED SECTIONS OF THE PRECAST CONCRETE CULVERT MAY BE CONSTRUCTED USING CHORDS.

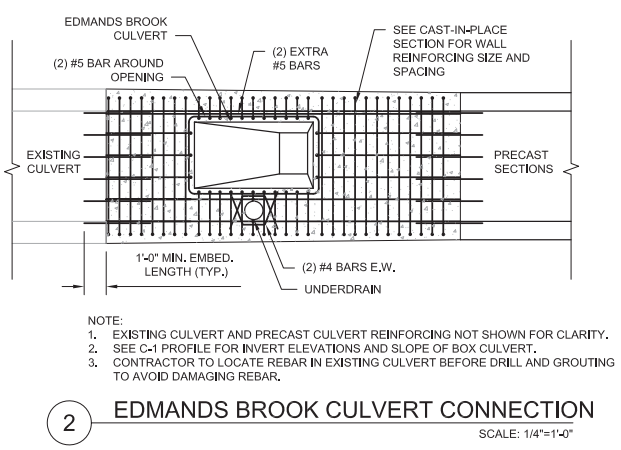
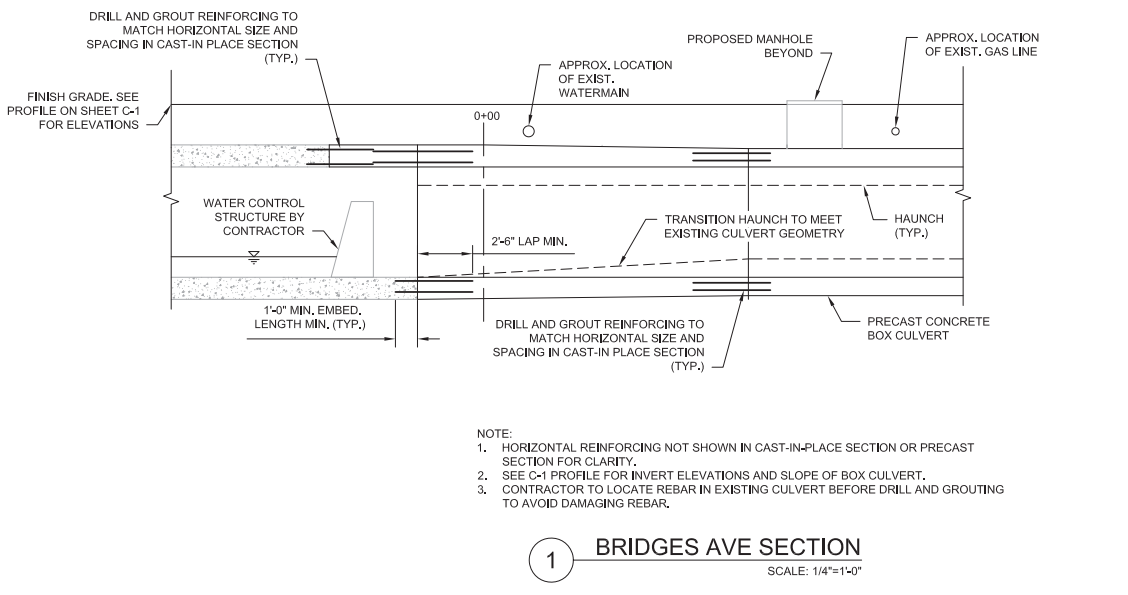

FOR PERMITTING

No.	Date	Dr. By	Ch. By	App. By	Description				
		A	P	R	O	V	E	D	DATE

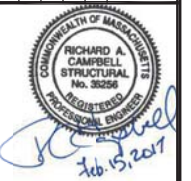

CITY OF NEWTON, MASSACHUSETTS DEPARTMENT OF PUBLIC WORKS		CONTRACT:	2160710	APP. BY:	RAC
LAUNDRY BROOK CULVERT REPLACEMENT		SCALE:	NOTED	CHK. BY:	SRB
CULVERT PLAN VIEW AND SECTIONS		DR. BY:	CJW	DES. BY:	CJW
FILE NO.	S-2	CADD NO.			

Z:\MA-Fabero-Projects\Newton, MA\Cabot School Culvert Repair\Cabot\Newton - Cabot School Culvert Repair.dwg

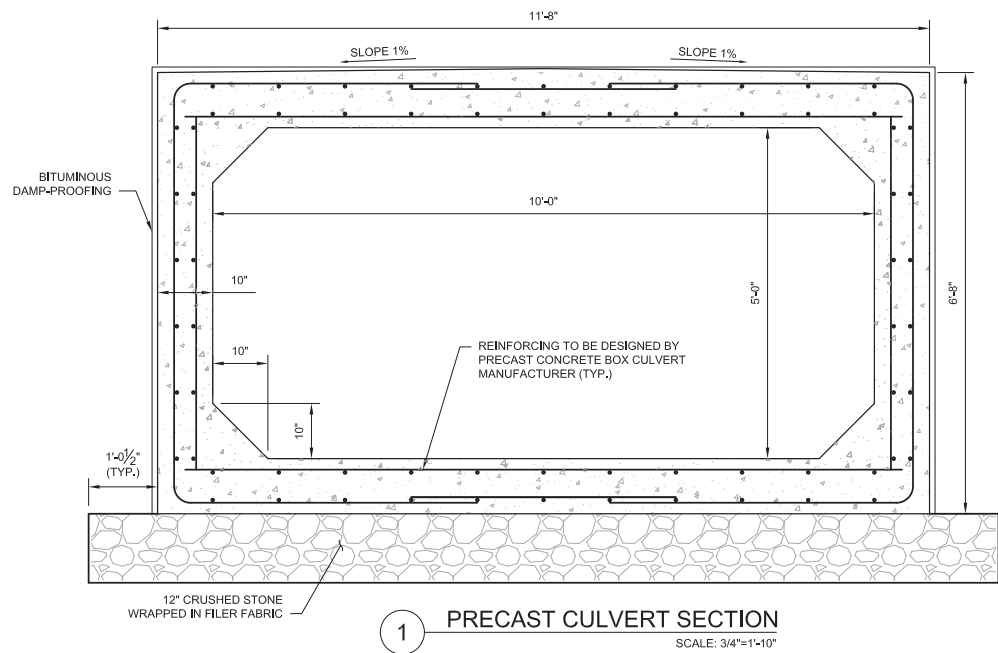

1 PRECAST CULVERT SECTION
 SCALE: 3/4"=1'-10"

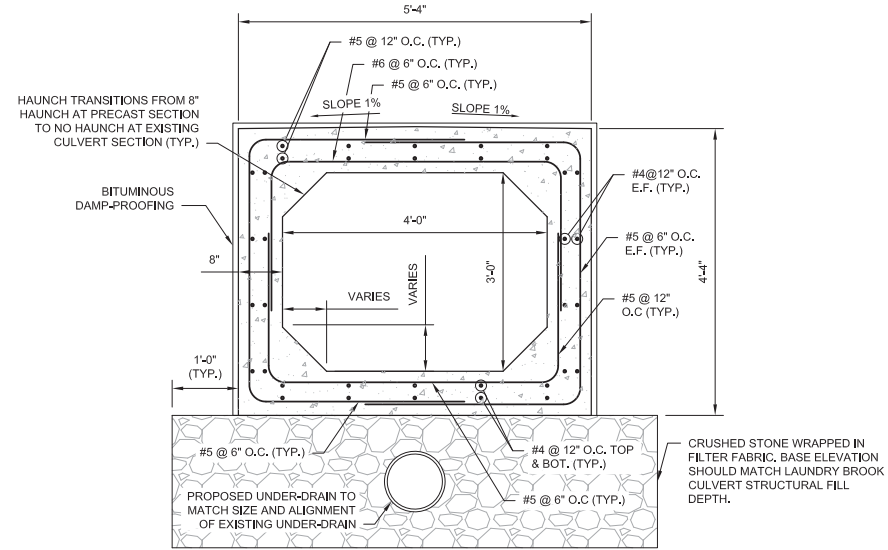

3 CAST-IN-PLACE CULVERT SECTION
 SCALE: 3/4"=1'-10"

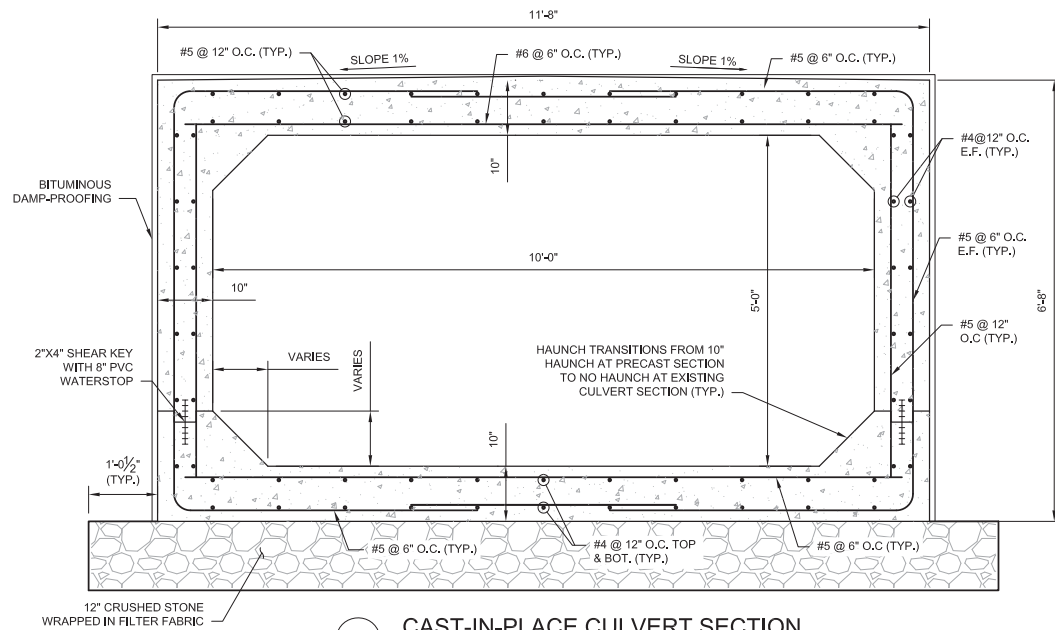

2 CAST-IN-PLACE CULVERT SECTION
 SCALE: 3/4"=1'-10"

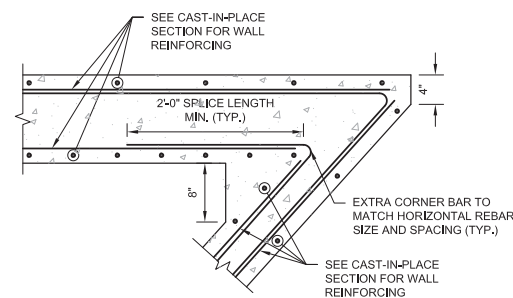

A DETAIL
 SCALE: 1"=1'-0"

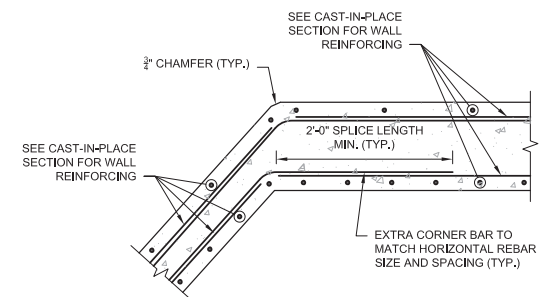

B DETAIL
 SCALE: 1"=1'-0"

No.	Date	Dr. By	Ck. By	App. By	Description
					A P P R O V E D
					REGISTERED PROFESSIONAL ENGINEER
					DATE



CITY OF NEWTON, MASSACHUSETTS DEPARTMENT OF PUBLIC WORKS		CONTRACT:	2160710	DRBY:	CJW	CHKBY:	SRB	APP. BY:	RAC
LAUNDRY BROOK CULVERT REPLACEMENT		SCALE:	NOTED	FILE NO.:					
CULVERT SECTIONS AND DETAILS									

FOR PERMITTING

S-3

Preliminary Construction Cost Estimate for Laundry Brook Culvert Replacement				
Item/Description	Quantity	Unit	Unit Cost	Total
Removal of Existing Concrete Culvert	392	LF	\$420.00	\$164,640.00
Temporary Excavation Support	8160	SF	\$42.00	\$342,720.00
Precast Concrete Culvert (5'x10')	392	LF	\$1,520.00	\$595,840.00
Precast Structure at Junction of Laundry Brook/Edmands Brook	1	LS	\$75,000.00	\$75,000.00
Control of Water/Diversion	1	LS	\$400,000.00	\$400,000.00
Surface Restoration and Traffic Management	1	LS	\$125,000.00	\$125,000.00
Sewer Crossing at Laundry Brook	1	LS	\$7,500.00	\$7,500.00
8" PVC Sewer (Dig repairs at 3 locations)	3	EA	\$15,000.00	\$45,000.00
12" PVC Drain	190	LF	\$400.00	\$76,000.00
			Subtotal =	\$1,831,700.00
			Contingency (30%) =	\$549,510.00
			Construction Total =	\$2,381,210.00
			Construction Administration Fees (15% of Construction Total) =	\$357,181.50
			Total Project Cost =	\$2,738,391.50

**Cabot Elementary School
Newton, MA
Culvert Replacement Estimate**



Date: 5/8/2017

Description	Quantity	Unit	\$/Unit	Total
<u>Site Prep and Demolition:</u>				
Erosion Control & maintain	650	LF	\$12.00	\$7,800
Temp. Fence	208	LF	\$10.00	\$2,080
Remove & reset existing shed	2	EA	\$1,000.00	\$2,000
Excavate on top and adjacent to the culvert and stockpile	2,650	CY	\$15.00	\$39,744
Demo & Dispose existing pre-cast culvert (10' W x 5'D) & MHs	365	LF	\$350.00	\$127,750
Demo manholes	2	ea	\$800.00	\$1,600
Load & dispose excavated material (Assume 50%)	1,325	CY	\$30.00	\$39,744
Remove portion of the top slab for water control	40	SF	\$120.00	\$4,800
Temporary Excavation support	4,900	SF	\$45.00	\$220,500
<u>Water Control</u>				
Build Dam structure for water control	1	LS	\$35,000.00	\$35,000
Install pumps and pipping and maintain	1	LS	\$45,000.00	\$45,000
Install temp Power and consumption for electric sum pumps	1	LS	\$35,000.00	\$35,000
<u>New Culvert Structures</u>				
Layout and grade for new culvert	8,030	SF	\$3.50	\$28,105
Install Crushed Stone Base with filter fabric	580	Tons	\$55.00	\$31,897
Install Precast concrete structures with crane (18 Tons)	42	Sections	\$4,500.00	\$189,000
Pre-cast pre-purchased pre-cast structure	1	LS	\$199,000.00	\$199,000
Structures, utilities openings and connectors & misc. hardware	345	LF	\$200.00	\$69,000
Laundry Brook Section - CIP Sections	25	LF	\$5,500.00	\$137,500
Edmund Brook Section - CIP Sections	10	LF	\$4,500.00	\$45,000
Repair top slab for water control	40	SF	\$250.00	\$10,000
Install new MHs	2	EA	\$4,500.00	\$9,000
Install membrane waterproofing at connections between existing and new structure	1	LS	\$4,500.00	\$4,500
Backfill and grade new culvert structures	2,650	CY	\$22.00	\$58,292
Imported structural fill (Assume to reuse 50% existing)	1,325	CY	\$25.00	\$33,120
<u>Utilities Relocation at Bridge Avenue</u>				
<u>Sanitary</u>				
Replace existing 8" VC with 8" PVC	143	LF	\$80.00	\$11,440
New PVC stub pipe	2	EA	\$1,500.00	\$3,000
New Sanitary SMH	2	EA	\$5,500.00	\$11,000
<u>Storm Drainage</u>				
Replace existing 12" VC pipe with 12" PVC pipe	185	LF	\$85.00	\$15,725
R/R existing DMH	1	EA	\$5,500.00	\$5,500
New DMH	2	EA	\$4,500.00	\$9,000
10" PVC Drain Plug	2	EA	\$1,200.00	\$2,400
New 12" PVC pipe to existing CB	26	EA	\$85.00	\$2,210
<u>Water System</u>				
Relocate existing 8" DI water main with new valves	30	LF	\$250.00	\$7,500

Description	Quantity	Unit	\$/Unit	Total
Temp water main	1,800	LF	\$35.00	\$63,000
Building connections	21	EA	\$1,500.00	\$31,500
Utilities Relocation at Parkview				
<u>Sanitary</u>				
Replace existing VC pipe with PVC and abandoned the connections	3	EA	\$1,500.00	\$4,500
Install new 12" DI pipe sleeve for new 8" PVC Pipe	16	LF	\$250.00	\$4,000
Replace existing 8" PVC and connect to SMH & pass thru Culvert	37	LF	\$120.00	\$4,440
Relocate 8" Water pipe at Parkview	58	LF	\$250.00	\$14,500
Traffic Management: @ Bridge Avenue				
Install temp site signage	23	ea	\$250.00	\$5,750
Temp. road marking	1	LS	\$5,000.00	\$5,000
Temp. fence, barrier at work zones (3 EA)	1	LS	\$24,000.00	\$24,000
Police Details - Allowance	1	LS	\$105,000.00	\$105,000
Misc.:				
Restore abutter's yards and misc. landscape & repair	1	LS	\$25,000.00	\$25,000
Paving and curbing restore at Bridge Street	1	LS	\$15,000.00	\$15,000
Street cleaning	20	Shifts	\$450.00	\$9,000
<u>Misc. Earthwork and Bid Allowances:</u>				
Excavation & Backfill of unsuitable material above the normal grade	100	CY	\$25.00	\$2,500
Excavation & Backfill of unsuitable material below the normal grade	500	CY	\$35.00	\$17,500
Excavation & Backfill of unsuitable material below the normal grade (Additional)	500	CY	\$35.00	\$17,500
Removal and Disposal of Contaminated Material	1,080	Tons	\$65.00	\$70,200
Test Pits	100	CY	\$100.00	\$10,000
Additional Crushed Stone	100	CY	\$60.00	\$6,000
Rock Excavation and Disposal (Minimum) w/ hoe-ram	100	CY	\$250.00	\$25,000
Rock Excavation and Disposal (Additional)	100	CY	\$250.00	\$25,000
Pavement Replacement	4,000	SF	\$5.00	\$20,000
Additional Pavement	20	Tons	\$250.00	\$5,000
Total Sub-Direct Cost ==>>>				\$1,952,598
GENERAL CONDITIONS/ REQUIREMENTS			12.00%	\$234,312
CM FEE			5.00%	\$97,630
BOND AND INSURANCE			1.75%	\$34,170
DESIGN & ESTIMATING CONTINGENCY			4.00%	\$78,104
ESCALATION			0.00%	\$0
CM CONTINGENCY			2.00%	\$39,052
Total Estimated Cost ==>>>				\$2,435,866



SETTI D. WARREN
MAYOR

City of Newton, Massachusetts
Office of the Mayor

#142-17

Telephone
(617) 796-1100
Telefax
(617) 796-1113
TDD
(617) 796-1089

E-mail
swarren@newtonma.gov

May 8, 2017

Honorable City Council
Newton City Hall
1000 Commonwealth Avenue
Newton Centre, MA 02459

RECEIVED
Newton City Clerk
2017 MAY - 8 PM 6:49
David A. Olson, GMC
Newton, MA 02459

Ladies and Gentlemen:

As a result of receiving a petition signed by 10 residents of the City, I write to request that your Honorable Council docket for consideration a request to transfer the following amounts to the Public Buildings Department for the development of a Public Information Plan regarding the site clean-up at the Horace Mann School for an oil leak that occurred in 1998.

<u>From Account #</u>	<u>Account</u>	<u>Amount</u>
0110498-5197	Wage & Salary Reserve	\$5,375
0110498-5790	Budget Reserve	\$3,810
June 30, 2016 Certified Free Cash		\$5,815

Thank you for your consideration of this matter.

Sincerely,

Setti D. Warren
Mayor

City of Newton



PUBLIC BUILDINGS DEPARTMENT

Josh Morse, Building Commissioner
Telephone (617) 796-1600
FAX (617) 796-1601
TTY: (617) 796-1608
52 ELLIOT STREET

NEWTON HIGHLANDS, MA 02461-1605

Setti D. Warren
Mayor

April 28, 2017

Mayor Setti D. Warren
Newton City Hall
1000 Commonwealth Avenue
Newton Centre, MA 02459

RECEIVED
Newton City Clerk
2017 APR 28 AM 10: 53
David A. Olson, CMC
Newton, MA 02459

RE: Funding for Horace Mann School Public Information Plan for Site Clean-up

Dear Mayor Warren:

The Public Buildings Department respectfully requests the following funding for a Public Information Plan regarding the Site Clean-up at the Horace Mann School, as a result of the receipt of the attached Petition from ten (10) City of Newton citizens, who are requesting a Public Information Plan for the Site Clean-up at the Horace Mann School for an oil leak that occurred in 1998, the City of Newton must have our LSP prepare the proper documentation required for this DEP Process, attend and preside at Public meeting(s) regarding this matter.

The initial anticipated cost for this work is \$15,000, with potentially additional costs depending on the outcome of the results of this PIP and Public meeting(s).

Sincerely,

Josh Morse
Public Buildings Commissioner

cc: Maureen Lemieux, Chief Financial Officer
Alex Valcarce, Program Director
Dori Zaleznik, Chief Admin Officer

We the undersigned request that the Horace Mann School Site, 687 Watertown Street, Newton, DEP Release Tracking Number 3-16552 be designated as a Public Involvement Plan Site under the provisions of M.G.L. c. 21E and the Massachusetts Contingency Plan, 310 CMR 40.1400.

Alison Leamy
Key Petitioner Signature *City Council*

192 Chapel St
Address

Alison Leamy
Lead Petitioner Printed Name

617-527-1182
Phone Number

Emily Norton
Signature

58 Prescott St Newton
Address

Emily Norton
Printed Name

617-795-0362
Phone Number

Normand Rousseau
Signature

86 Prescott St
Address

Normand Rousseau
Printed Name

617-527-1358
Phone Number

Helen Rousseau
Signature

86 PRESCOTT ST NEWTON
Address

HELEN ROUSSEAU
Printed Name

617-974-1919
Phone Number

[Signature]
Signature

87 Prescott St
Address

Brian Sullivan
Printed Name

617 842 9706
Phone Number

Robert Norton
Signature

62 West St. Newton
Address

Robt Norton
Printed Name

857-222-5391
Phone Number

We the undersigned request that the Horace Mann School Site, 687 Watertown Street, Newton, DEP Release Tracking Number 3-16552 be designated as a Public Involvement Plan Site under the provisions of M.G.L. c. 21E and the Massachusetts Contingency Plan, 310 CMR 40.1400.

[Handwritten Signature]

Signature

Laura Sullivan

Printed Name

81 Prescott St

Address

617 244 7224

Phone Number

[Handwritten Signature]

Signature

Susan Grednick

Printed Name

30 Wedgewood Rd. 02465

Address

617-460-6619

Phone Number

[Handwritten Signature]

Signature

STEPHANO MAVANNOU

Printed Name

62 PRESCOTT ST.

Address

617 964 0133

Phone Number

[Handwritten Signature]

Signature

Lois Bienen

Printed Name

62 Prescott St.

Address

617 964 0133

Phone Number

Signature

Printed Name

Address

Phone Number

Signature

Printed Name

Address

Phone Number

We the undersigned request that the Horace Mann School Site, 687 Watertown Street, Newton, DEP Release Tracking Number 3-16552 be designated as a Public Involvement Plan Site under the provisions of M.G.L. c. 21E and the Massachusetts Contingency Plan, 310 CMR 40.1400.

Alison M. Leary Alison M. Leary
Key Petitioner Signature City Council Lead Petitioner Printed Name

192 Chapel St 617-527-1182
Address Phone Number

Amy Tai Amy Tai
Signature Printed Name

66 Allison St. #1 857-231-0360
Address Phone Number

Mary Mooradian Mary Mooradian
Signature Printed Name

190 Chapel St 617-332-7594
Address Phone Number

Signature Printed Name

Address Phone Number

Signature Printed Name

Address Phone Number

Signature Printed Name

Address Phone Number



SETTI D. WARREN
MAYOR

City of Newton, Massachusetts
Office of the Mayor

#143-17

Telephone
(617) 796-1100

Telefax
(617) 796-1113

TDD
(617) 796-1089

E-mail
swarren@newtonma.gov

May 8, 2017

Honorable City Council
Newton City Hall
1000 Commonwealth Avenue
Newton Centre, MA 02459

RECEIVED
Newton City Clerk
2017 MAY -8 PM 6:49
David A. Olson, CMC
Newton, MA 02459

Ladies and Gentlemen:

I write to request that your Honorable Council docket for consideration a request to authorize the acceptance and expenditure of the sum of \$22,400 from a Massachusetts Emergency Management Grant. Funds from this grant will be used to purchase equipment and related items for the new Emergency Operations Center.

Thank you for your consideration of this matter.

Sincerely,

Setti D. Warren
Mayor



City of Newton, Massachusetts
Office of the Mayor

SETTI D. WARREN
MAYOR

#89-17
Telephone
(617) 796-1100
Telefax
(617) 796-1113
TDD
(617) 796-1089

E-mail
swarren@newtonma.gov

March 27, 2017

Honorable City Council
Newton City Hall
1000 Commonwealth Avenue
Newton Centre, MA 02459

RECEIVED
Newton City Clerk
2017 MAR 27 PM 2:20
David A. Olson, OMC
Newton, MA 02459

Ladies and Gentlemen:

I write to request that your Honorable Council docket for consideration a request to authorize the transfer of \$75,000 from Acct # 0111401-511001 Planning Department Full time Salaries and \$50,000 from Acct # 0111404-511001 Economic Development Full Time Salaries to a specific project account to be established for the purpose of funding the creation of a citywide Economic Development Strategy.

Thank you for your consideration of this matter.

Sincerely,

Setti D. Warren
Mayor



Setti D. Warren
Mayor

City of Newton, Massachusetts
Department of Planning and Development
1000 Commonwealth Avenue Newton, Massachusetts 02459

Telephone
(617) 796-1120
Telefax
(617) 796-1142
TDD/TTY
(617) 796-1089
www.newtonma.gov

Barney S. Heath
Director

MEMORANDUM

April 6, 2017

TO: Maureen Lemieux, Chief Financial Officer/Chief of Staff

FROM: Barney Heath, Director of Planning & Development 

SUBJECT: Economic Development Strategy Request

The City recently completed comprehensive studies for both our housing and transportation sectors, along with a corresponding implementation strategy for each. As we look ahead to the next fiscal year and beyond, we would like to undertake a similar data-driven analysis of the City's economic development sector along with specific policy recommendations and a corresponding implementation strategy.