

REVISIONS	No.	Date	Desc.	CONSERVATION	COMMISSION	COMMENTS
	1.	2/19/2016	ENGINEERING			COMMENTS
	2.	2/22/2016	ENGINEERING			COMMENTS
	3.	2/29/2016	CONSERVATION			COMMENTS

Designed: A.B.U.  
Drawn: A.B.U.  
Checked:  
Approved: NTS  
Scale: 1502781  
Project No: 1502781  
Date: 2/5/2016  
CAD File: DN150278101

Title: DETAILS

Sheet No.

DN-1

Xref (G): : B0150278101

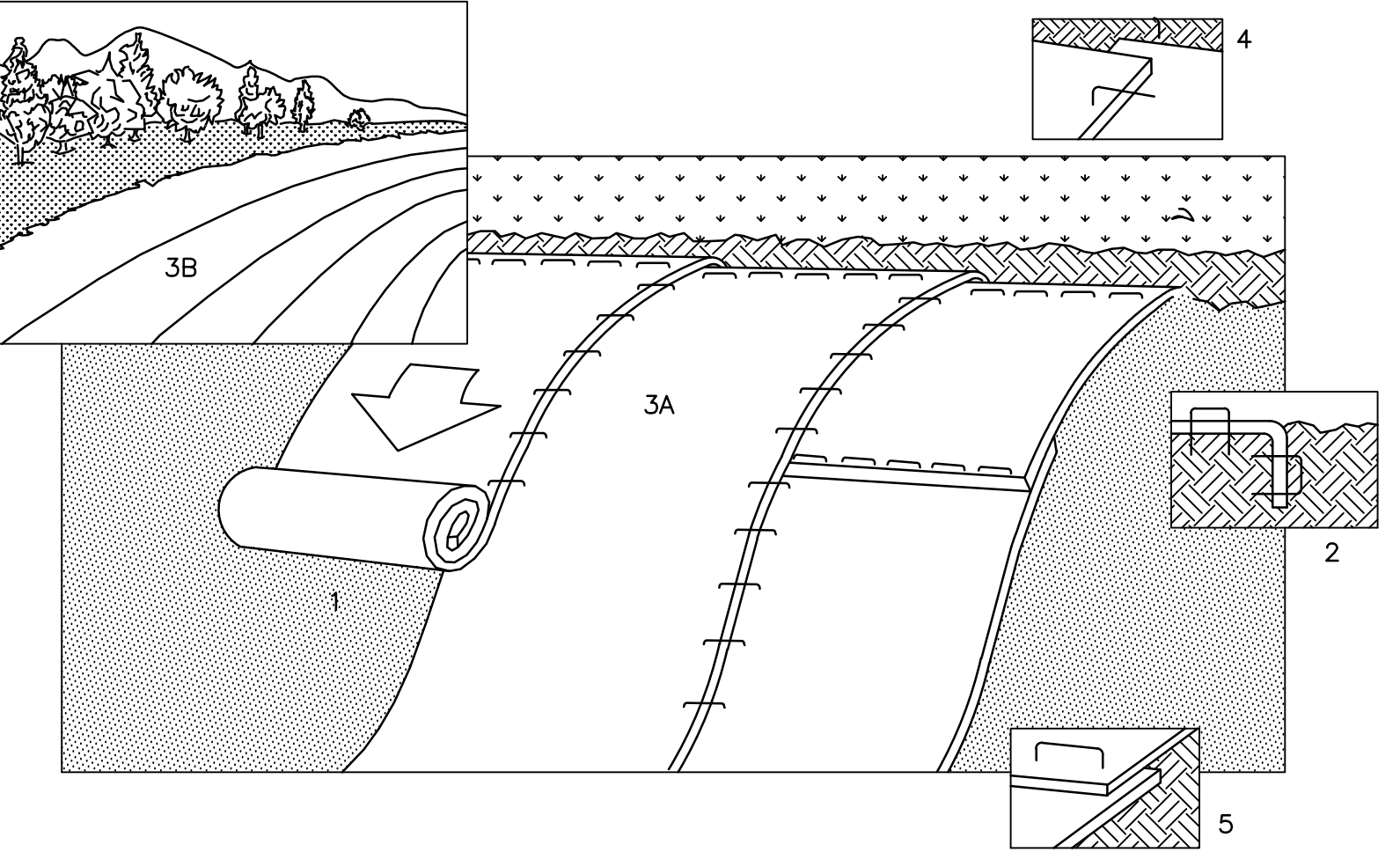
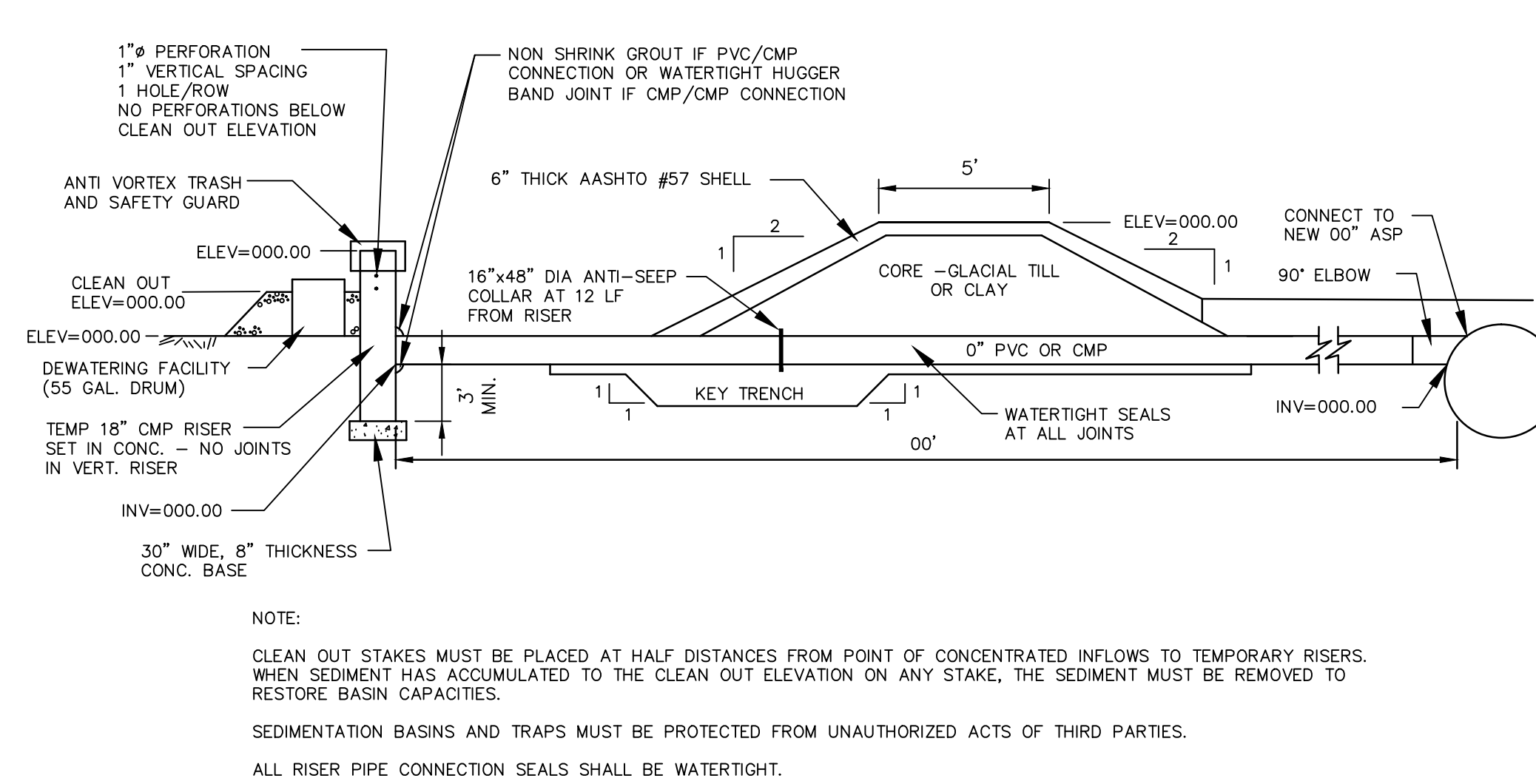
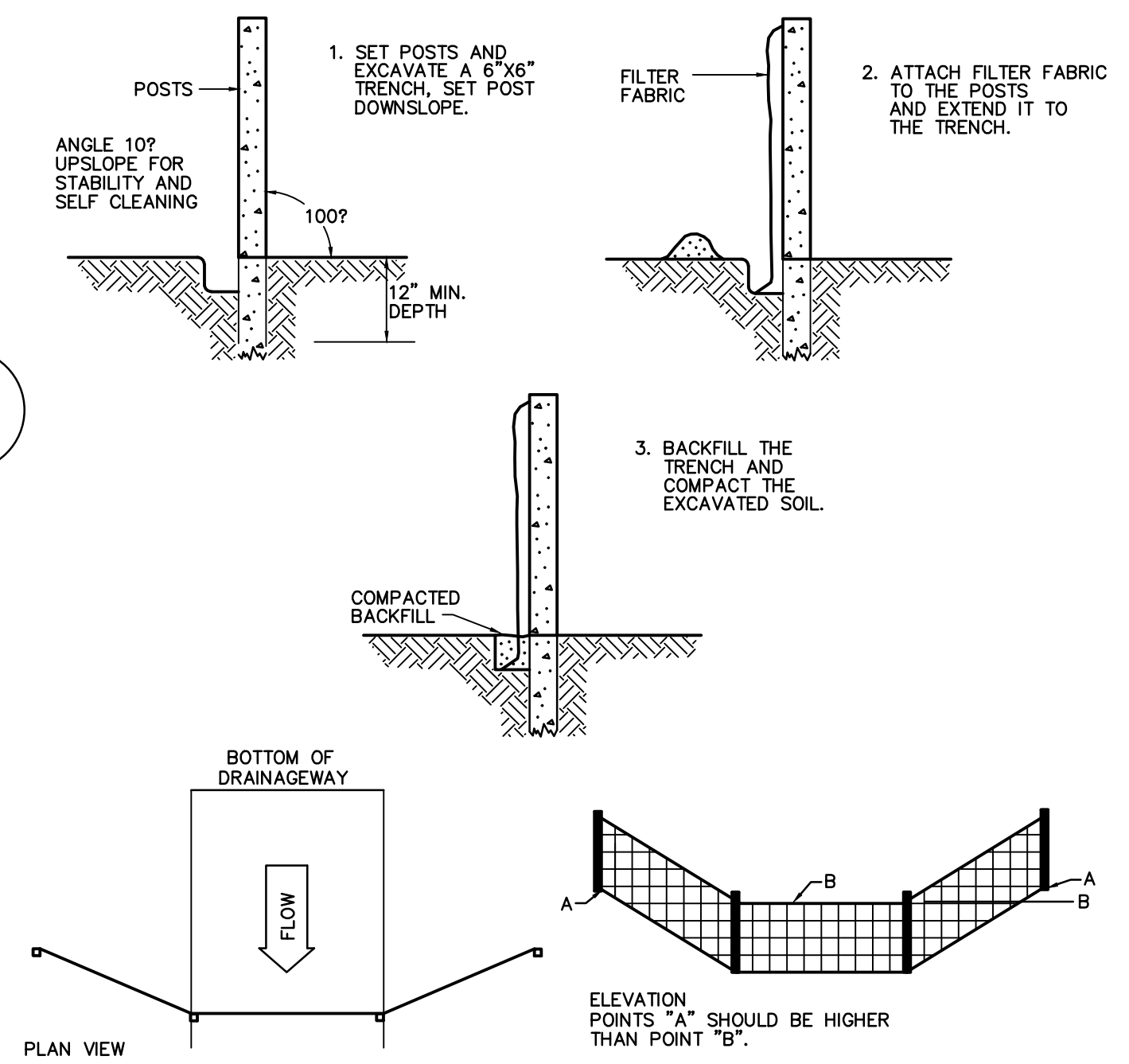

1. PREPARE SOIL BEFORE INSTALLING BLANKETS, INCLUDING APPLICATION OF LIME, FERTILIZER, AND SEED.  
2. BEGIN AT THE TOP OF THE SLOPE BY ANCHORING THE BLANKET IN 6" DEEP X 6" WIDE TRENCH. BACKFILL AND COMPACT THE TRENCH AFTER STAPLING.  
3. ROLL THE BLANKETS (A.) DOWN OR (B.) HORIZONTALLY ACROSS THE SLOPE.  
4. THE EDGES OF PARALLEL BLANKETS MUST BE STAPLED WITH APPROXIMATELY 2" OVERLAP.  
5. WHEN BLANKETS MUST BE SPICED DOWN THE SLOPE, PLACE BLANKETS END OVER END (SHINGLE STYLE) WITH APPROXIMATELY 4" OVERLAP. STAPLE THROUGH OVERLAPPED AREA, APPROXIMATELY 12" APART.

