

CITY OF NEWTON
PURCHASING DEPARTMENT

CONTRACT FOR PUBLIC WORKS DEPARTMENT
(M.G.L. Ch. 30, Sec. 39M)

PROJECT MANUAL:
PARKING METER REMOVAL, SIGNS, and BOLLARDS

INVITATION FOR BID #22-02

Bid Opening Date: August 5, 2021 at 10:00 a.m.

JULY 2021

Ruthanne Fuller, Mayor

CITY OF NEWTON

PROJECT MANUAL TABLE OF CONTENTS

PARKING METER REMOVAL, SIGNS, AND BOLLARDS

	<u>Page #</u>
Cover Page	1
Table of Contents	2
 <u>Part 1 - Bidding Documents, Contract Forms, and Conditions of the Contract</u>	
1. - Invitation for Bid	3-4
2. - Instructions to Bidders	5-8
3. - Bid Form	9-11
4. - Bidder's Qualification Forms	
▪ Bidder's Qualifications and References Form	12-13
▪ Certificate of Non-Collusion	14
▪ Certification of Tax Compliance	15
▪ Certificate of Foreign Corporation	16
▪ Debarment Letter	17
▪ IRS Form W-9	18
5. - Contract Forms (Informational only. Not required at time of bid submittal)	19
▪ Contractor Contract	20-21
▪ Certificate of Authority - Corporate	22
▪ Payment Bond	23
6. - General Conditions of the Contract	24-32
7. - Wage Rate Requirements	33-34
▪ Prevailing Wages	35-66
▪ The Mass. Prevailing Wage Law	67
▪ Statement of Compliance	68
▪ Weekly Payroll Report Form	69
8. - Work	
▪ Trench Permit	70-74
▪ Location of Work	75
▪ Item Sheets	76-78
▪ General Detail Drawing	79-80

Part 2 – General Requirements and Project Specifications

General Requirements	81-90
Scope of Work	91-98
Construction Specifications	99-107

END OF SECTION

CITY OF NEWTON
PURCHASING DEPARTMENT
INVITATION FOR BID #22-02

The City of Newton invites sealed bids in accordance with M.G.L. c.30, §39M from Contractors for:

PARKING METER REMOVAL, SIGNS, and BOLLARDS

Bids will be received until: **10:00 a.m., Thursday, August 5, 2021***
at the Purchasing Department, Room 108, Newton City Hall, 1000 Commonwealth Avenue, Newton, MA 02459. Bids will not be accepted nor may submitted bids be corrected, modified or withdrawn after the deadline for bids. Immediately following the deadline for bids, all bids received within the time specified will be publicly opened and read aloud.

***To promote the health and safety of City workers and the public, Newton City Hall is still observing COVID restrictions. The City has adopted the following procedures that may affect your participation in this bid:**

- 1. Bidders who wish to attend the Bid Opening can do so by telephone conference call. To attend, call 617.454.5555. When prompted, enter Participant Passcode 1220#. There will be no in person meetings.**
- 2. You may drop off bids in Room 108. However, bids not received in Room 108 by mail or courier may, if you choose, may be dropped off in a locked drop box at the top of the stairs to left of the main door to City Hall. The box will be checked at the scheduled submission deadline.**
- 3. Bids results will be scanned and posted as soon as practicable after the opening. Copies of bids will be available on written request.**

The City will only accept bids from contractors prequalified by the Massachusetts Department of Transportation (MassDOT). MassDOT will provide the City a list of prequalified contractors. Bidders will be verified at time of Bid Opening.

The work under this Contract shall consist of furnishing all necessary labor, materials and equipment required to remove existing parking meter poles, install new signs and sign posts, and install bollards, as described in the Project Manual (unless specifically indicated as not to be done), and all other work as directed by the City Engineer. The work shall be performed at multiple municipal locations throughout the City of Newton.

SPECIAL CONSIDERATIONS:

- A. The project may require construction in areas occupied by business owners, their employees and customers.
- B. Bidder must accommodate employees and customers visiting businesses adjacent to a work zone.
- C. Pedestrian access and safety around the construction area in conformance with the latest edition of the Manual on Uniform Traffic Control Devices (MUTCD) is the responsibility of the Bidder.
- D. Upon completion of the work the affected areas, including areas within the businesses disturbed during construction, shall be restored to original condition.
- E. The contractor shall review all project limits with the Engineer prior to commencement of work.

This Invitation For Bid (IFB) and all related documents and attachments (collectively, "Contract Documents") will be available online at: www.newtonma.gov/bids or pick up at the Purchasing Department after **10:00 A.M. on July 22, 2021**. **Bids must be submitted with one Original and one Copy.**

A bid deposit in an amount that is not less than five percent (5%) of the value of the bid, including all add alternates, is required. Bid deposits, payable to the City of Newton, shall be either in the form of a bid bond, or cash, or a certified check on, or a treasurer's or cashier's check issued by, a responsible bank or trust company. The City of Newton will award the contract to the lowest eligible and responsible bidder. Please Note: this bid, in accordance with the Chapter 303 Acts of 2008, contains Price Adjustments and new Prevailing Wage requirements. All bidders are required to familiarize themselves with these terms and conditions before submitting a bid.

Bidders are reminded that the bid deposit covers the City for damages when a bidder withdraws its bid after the bid submission date. **Be advised that to the extent permitted by the law the City will retain all bid deposits for withdrawn bids.**

The costs of any bond and any insurance required in this IFB are the responsibility of the bidder; such costs will not be reimbursed by City and should be included in your bid.

**It is anticipated work will start upon execution of contract, when a Notice to Proceed shall be issued.
Time for completion is two (2) months from the Notice to Proceed.**

All bids are subject to the provisions of M.G.L. Chapter 30, Section 39M. **Wages are subject** to minimum wage rates determined by the Massachusetts Department of Labor and Industries pursuant to M.G.L. Chapter 149, Sec. 26 to 27H. The schedule of wage rates applicable to this contract is included in the bidding documents. In addition, the prevailing wage schedule will be updated annually for all public construction projects lasting longer than one (1) year. You will be required to pay the rates set out in any updated prevailing wage schedule. Increases in prevailing wage schedules will not be the basis for change order requests. The successful bidder will be required to provide a Certificate of Insurance demonstrating current coverage of the type and amounts set forth in the Project Manual. The successful bidder will be required to furnish a **Labor and Materials Payment Bond in the amount of 50%** of the contract total. Wages are paid to drivers for all “on-site” work.

Once you’ve downloaded this bid from the internet website www.newtonma.gov/bids I strongly suggest you email (purchasing@newtonma.gov) your company’s Name, address, EMAIL, phone, fax AND the INVITATION FOR BID NUMBER and Project Title, so that we may add you to the Bidders List and you will be notified of any/all addendums.

The City will reject any and all bids in accordance with the above referenced General Laws. In addition, the City reserves the right to waive minor informalities in any or all bids, or to reject any or all bids (in whole or in part) if it be in the public interest to do so.

In the event that any person wishes to attend a bid opening or pre-bid meeting, accessible and reasonable accommodations will be provided to persons requiring assistance. If you need a reasonable accommodation, please contact the city of Newton’s ADA Coordinator, Jini Fairley, at least two business days in advance of the meeting: jfairley@newtonma.gov or (617) 796-1253. For Telecommunications Relay Service, please dial 711.

CITY OF NEWTON



Nicholas Read
Chief Procurement Officer
July 22, 2021

CITY OF NEWTON
DEPARTMENT OF PURCHASING
INSTRUCTIONS TO BIDDERS

ARTICLE 1 - BIDDER'S REPRESENTATION

- 1.1 Each General Bidder (hereinafter called the "Bidder") by making a bid (hereinafter called "bid") represents that:
 1. The Bidder has read and understands the Bidding Documents, Contract Forms, General Conditions, Conditions of the Contract, General Requirements and Project Specifications (collectively, referred to as the "Contract Documents") and the bid is made in accordance therewith.
 2. The Bidder is familiar with the local conditions under which the work has to be performed.
- 1.2 Failure to so examine the Contract Documents and work site will not relieve any Bidder from any obligation under the bid as submitted.

ARTICLE 2 - REQUEST FOR INTERPRETATION

- 2.1 Bidders shall promptly notify the City of any ambiguity, inconsistency, or error which they may discover upon examination of the Contract Documents, the site, and local conditions.
- 2.2 Bidders requiring clarification or interpretation of the Contract Documents shall make a written request to the *Chief Procurement Officer*, at purchasing@newtonma.gov or via facsimile (617) 796-1227. The City will only answer such requests if received by **Friday, July 30, 2021 at 12:00 noon**. In the event that the bid opening date is changed, the deadline for informational requests may also change as provided in an addendum issued by the City.
- 2.3 Interpretation, correction, or change in the Contract Documents will be made by addendum which will become part of the Contract Documents. The City will not be held accountable for any oral communication.
- 2.4 Addenda will be emailed to every individual or firm on record as having taken a set of Contract Documents. Addenda will be emailed to every individual or firm on record as having taken a set of Contract Documents. Receipt of all addenda issued must be acknowledged in the Bid Form. **YOUR FAILURE TO ACKNOWLEDGE ALL ADDENDA MAY RESULT IN YOUR BID BEING REJECTED AS NON-RESPONSIVE.**
- 2.5 Copies of addenda will be made available for inspection at the location listed in the Invitation for Bids where Contract Documents are on file, in addition to being available online at www.newtonma.gov/bids.
- 2.6 Bidders or proposers contacting ANY CITY EMPLOYEE regarding an Invitation for Bid (IFB) or a Request for Proposal (RFP), outside of the Purchasing Department, once an IFB or RFP has been released, may be disqualified from the procurement process.
- 2.7 Bidders downloading information off the internet web site are solely responsible for obtaining any addenda prior to the bid opening. If the bidder makes itself known to the Purchasing Department, at purchasing@newtonma.gov or via facsimile (617) 796-1227, it shall be placed on the bidder's list. Bidders must provide the Purchasing Department with their company's name, street address, city, state, zip, phone, fax, email address and **INVITATION FOR BID #22-02**.

ARTICLE 3 - MBE PARTICIPATION

- 3.1 Notice is hereby given that the Mayor's Affirmative Action Plan for the City of Newton in effect at the time of this solicitation is applicable to all construction contracts in excess of \$10,000.00.
- 3.2 Notice is hereby given that the City of Newton Minority/Women Business Enterprise Plan and the Supplemental Equal Employment Opportunity Anti-Discrimination and Affirmative Action Program in effect at the time of this solicitation are applicable to all City contracts for goods and services in excess of \$50,000.00.
- 3.3 Copies of the Plans and Program referred to in Sections 3.1 and 3.2 are available at: www.newtonma.gov/purchasing.

ARTICLE 4 - PREPARATION AND SUBMISSION OF BIDS

- 4.1 Bids shall be submitted on the "Bid Form #22-02," attached.
- 4.2 All entries on the Bid Form shall be made by typewriter or in ink.
- 4.3 Where so indicated on the Bid Form, sums shall be expressed in both words and figures. Where there is a discrepancy between the bid sum expressed in words and the bid sum expressed in figures, the words shall control.
- 4.4 Bid Deposits shall be submitted in the amount specified in the Invitation for Bids. They shall be made payable to the City and shall be either in the form of cash, certified check, treasurer's or cashier's check issued by a responsible bank or trust company, or a bid bond issued by a surety licensed to do business in the Commonwealth of Massachusetts; and shall be conditioned upon the faithful performance by the principal of the agreements contained in the bid. Bidders are reminded that the bid deposit covers the City for damages when a bidder withdraws its bid after the bid submission date. **Be advised that to the extent permitted by the law the City will retain all bid deposits for withdrawn bids.**

Bid deposits of the three (3) lowest responsible and eligible Bidders shall be retained until the execution and delivery of the City-Contractor agreement.

- 4.5 The Bid, including the bid deposit shall be enclosed in a sealed envelope with the following plainly marked on the outside:

- * GENERAL BID FOR: **#22-02**
- * NAME OF PROJECT: **Parking Meter Removal, Signs, and Bollards**
- * BIDDER'S NAME, BUSINESS ADDRESS, AND PHONE NUMBER

- 4.6 Date and time for receipt of bids is set forth in the Invitation for Bids.
- 4.7 Timely delivery of a bid at the location designated shall be the full responsibility of the Bidder. In the event that Newton City Hall is closed on the date or at the time that bids are due, the date and time for receipt of bids shall be on the next business day following that the Newton City Hall and the Purchasing Department are open.
- 4.8 Bids shall be submitted with one **original** and one **copy**.
- 4.9 Massachusetts law requires all employees who work on Massachusetts public works construction sites must have no Less than 10 hours of OSHA-approved safety and health training. See M.G.L. c.30, §39M(c), M.G.L. c.30, §39S(a)(1), M.G.L. c.149, §44E(2) & M.G.L. c.149, §44F(2).
1. This requirement will apply to any general bid or sub bid submitted.
 2. This law directs the Massachusetts Attorney General to restrain the award of construction contracts to any contractor who is in violation to this requirement and to restrain the performance of these contracts by non-complying contractors.
 3. The contractor and all subcontractors on this project must certify on the Bid Form compliance with the applicable requirement. Non-compliance with this law will disqualify the bidder.

ARTICLE 5 - ALTERNATES

- 5.1 Each Bidder shall acknowledge alternates (if any) in Section C on the Bid Form.
- 5.2 In the event an alternate does not involve a change in the amount of the base bid, the Bidder shall so indicated by writing "No Change", or "N/C" or "0" in the space provided for that alternate.
- 5.3 Bidders shall enter on the Bid Form a single amount for each alternate which shall consist of the amount for work performed by the Contractor.
- 5.4 The low Bidder will be determined on the basis of the sum of the base bid and the accepted alternates.

ARTICLE 6 - WITHDRAWAL OF BIDS

- 6.1 Any bid may be withdrawn prior to the time designated for receipt of bids on written or electronic request. Electronic withdrawal of bids must be confirmed over the Bidder's signature by written notice postmarked on or before the date and time set for receipt of bids.
- 6.2 Withdrawn bids may be resubmitted up to the time designated for the receipt of bids.
- 6.3 No bids may be withdrawn within sixty (60) days, Saturdays, Sundays and legal holidays excluded, after the opening of the bids.

ARTICLE 7 - CONTRACT AWARD

- 7.1 The City is soliciting prices for items set forth in the Item Sheets at pp. 76-78 below. It is the City's intent to award one (1) contract to the responsible and eligible bidder offering the lowest Contract Price on Bid Form #22-02 below. A contract will be awarded within sixty (60) days, Saturdays, undays, and legal holidays excluded, after the opening of bids.
- 7.2 The City reserves the right to waive minor informalities in or to reject any or all Bids if it be in the public interest to do so.
- 7.3 The City reserves the right to reject any bidder who has failed to pay any local taxes, fees, assessments, betterments, or any other municipal charge, unless the bidder has a pending abatement application or has entered into a payment agreement with the collector-treasurer.
- 7.4 As used herein, the term "lowest responsible and eligible Bidder" shall mean the Bidder (1) whose bid is the lowest of those bidders possessing the skill, ability and integrity necessary for the faithful performance of the work; (2) who has met all the requirements of the invitation for bids; (3) who shall certify that he is able to furnish labor that can work in harmony with all other elements of labor employed or to be employed in the work; (4) who, where the provisions of section eight B of chapter twenty-nine apply, shall have been determined to be qualified thereunder.
- 7.5 Subsequent to the award and within five (5) days, Saturday, Sundays and legal holidays excluded, after the prescribed forms are presented for signature, the successful Bidder shall execute and deliver to the City a contract in the form included in the Contract Documents in such number of counterparts as the City may require.
- 7.6 In the event that the City receives low bids in identical amount from two or more responsive and responsible Bidders, the City shall select the successful Bidder by a blind selection process chosen by the City such as flipping a coin or drawing names from a hat. The low Bidders who are under consideration will be invited to attend and observe the selection process.

ARTICLE 8 - TAXES

- 8.1 The Bidder shall not include in this bid any tax imposed upon the sale or rental of tangible personal property in this Commonwealth, such as any and all building materials, supplies, services and equipment required to complete the work.
- 8.2 The City is exempt from payment of the Massachusetts Sales Tax, and the Bidder shall not include any sales tax on its bid. The City's exemption Number is E-046-001-404.

ARTICLE 9 – PROPRIETARY SPECIFICATIONS

- 9.1 The City may have used a proprietary specification to describe the supply listed in the specifications. Such specifications are permitted under M.G.L. c. 30, §39M(b), provided that the City states in writing that use of the proprietary specification is in its best interest and that it will accept an "equal" of the item specified. An item is considered equal if (i) it is at least equal in quality, durability, appearance, strength, and design; (ii) will perform the intended function at least equally; and (iii) conforms substantially, even with deviations, to the detailed requirements contained in the specifications. In the event that the Bidder wishes to substitute an equal item, it may do so either in its bid or proposal or after the contract is awarded but before a contract is executed, it being understood that the award shall be conditioned on the Bidder providing the item originally specified or an equal item accepted by the City and identified in the contract. In no event shall the Bidder be entitled to offer, or the City obliged to consider, the substitution of an item as equal after execution of a contract. In the event the Bidder substitutes or attempts to substitute an "equal" item after that date, it shall

be in breach thereof and be liable for actual and consequential damages resulting from its failure to perform as agreed. The City shall have the sole right to determine whether or not said item is equal.

- 9.2 The required determination and justification have been duly prepared, and a copy may be requested in accordance with the Massachusetts Public Records Law, M.G.L. c. 66, §10.

END OF SECTION

CITY OF NEWTON

DEPARTMENT OF PURCHASING

BID FORM #22-02

- A. The undersigned proposes to supply and deliver the materials specified below in full accordance with the Contract Documents and Project Manual supplied by the City of Newton entitled:

PARKING METER REMOVAL, SIGNS, and BOLLARDS

for the Contract Price specified below, subject to additions and deduction according to the terms of the specifications.

- B. This bid includes addenda number(s) _____, _____, _____, _____.

- C. The Contractor shall insert prices for each item in ink, in both words and figures.

_____ Dollars and \$ _____

(Contract Price shall equal the Total Bid at p. 78 from Item Sheets at pp. 76-78 below.)

COMPANY NAME: _____

- D. The undersigned has completed and submits herewith the following documents:

- Bidder's Qualifications and References Form, 2 pages
- Certificate of Non-Collusion, 1 page
- Certification of Tax Compliance, 1 page
- Certificate of Foreign Corporation (if applicable), 1 page
- Debarment Letter, 1 page
- IRS Form W-9, 1 page
- Signed Bid Form, 3 pages
- Item Sheets, 3 pages
- A five percent (5%) bid deposit.
- Trench Permit issued pursuant to G.L. c. 82A §1 and 520 CMR 7.00 et seq.(as amended)

- E. Prompt Payment Discounts. Bidders are encouraged to offer discounts in exchange for an expedited payment. Payments may be issued earlier than the general goal of within 30 days of receipt of the invoice only when in exchange for discounted prices. Discounts will not be considered in determining the lowest responsible bidder.

Prompt Payment Discount _____% _____ Days
 Prompt Payment Discount _____% _____ Days
 Prompt Payment Discount _____% _____ Days

- F. The undersigned agrees that, if selected as general contractor, s/he will within five days, Saturdays, Sundays and legal

holidays excluded, after presentation thereof by the City of Newton, execute a contract in accordance with the terms of this bid **and furnish a labor and materials payment bond** of a surety company qualified to do business under the laws of the commonwealth and satisfactory to the City of Newton in the **sum not less than 50% of the contract price**, the premiums for which are to be paid by the contractor and are included in the contract price.

The undersigned hereby certifies that s/he is able to furnish labor that can work in harmony with all other elements of labor employed or to be employed on the work and that s/he will comply fully with all laws and regulations applicable to awards made subject to section forty-four A of M.G.L. Chapter 30, s 39M.

The undersigned certifies that he is able to furnish labor that can work in harmony with all other elements of labor employed or to be employed in the work; (2) that all employees to be employed at the worksite will have successfully completed a course in construction safety and health approved by the United States Occupational Safety and Health Administration ("OSHA") that is at least 10 hours in duration at the time the employee begins work and who shall furnish documentation of successful completion of said course with the first certified payroll report for each employee; and (3) that all employees to be employed in the work subject to this bid have successfully completed a course in construction safety and health approved by the United States OSHA that is at least 10 hours in duration. The undersigned understands that any employee found on a worksite subject to this section without documentation of successful completion of a course in construction safety and health approved by the United States Occupational Safety and Health Administration that is at least 10 hours in duration shall be subject to immediate removal.

The undersigned further certifies under the penalties of perjury that this bid is in all respects bona fide, fair and made without collusion or fraud with any other person. As used in this subsection the word "person" shall mean any natural person, joint venture, partnership, corporation or other business or legal entity. The undersigned further certifies under penalty of perjury that the said undersigned is not presently debarred from doing public construction work in the Commonwealth under the provisions of section twenty-nine F of chapter twenty-nine, or any other applicable debarment provisions of any other chapter of the General Laws or any rule or regulation promulgated thereunder.

The undersigned further certifies under the penalties of perjury that they have familiarized themselves with the changes to the Prevailing Wage Rates, Price Adjustment Clauses, in accordance to Chapter 303 Acts of 2008.

G. Environmentally preferable products information (which is requested but which will not be considered in awarding a contract):

Description of environmental attributes of Bidder's goods or services:

Steps taken to (a) identify any positive or negative environmental attributes of products or services and (b) ensure that those attributes are being addressed as part of operations:

Date _____

_____ (Name of General Bidder)

BY: _____

_____ (Printed Name and Title of Signatory)

_____ (Business Address)

_____ (City, State Zip)

_____ / _____ (Telephone) (FAX)

_____ (E-mail address)

NOTE: If the bidder is a corporation, indicate state of incorporation under signature, and affix corporate seal; if a partnership, give full names and residential addresses of all partners; if an individual, give residential address if different from business address; and, if operating as a d/b/a give full legal identity. Attach additional pages as necessary.

END OF SECTION

CITY OF NEWTON

BIDDER'S QUALIFICATIONS AND REFERENCES FORM

All questions must be answered, and the data given must be clear and comprehensive. Please type or print legibly. If necessary, add additional sheet for starred items. This information will be utilized by the City of Newton for purposes of determining bidder responsiveness and responsibility with regard to the requirements and specifications of the Contract.

- 1. FIRM NAME: _____
- 2. WHEN ORGANIZED: _____
- 3. INCORPORATED? _____ YES _____ NO DATE AND STATE OF INCORPORATION: _____
- 4. IS YOUR BUSINESS A **MBE**? _____ YES _____ NO **WBE**? _____ YES _____ NO or **MWBE**? _____ YES _____ NO
- * 5. LIST ALL CONTRACTS CURRENTLY ON HAND, SHOWING CONTRACT AMOUNT AND ANTICIPATED DATE OF COMPLETION:

- * 6. HAVE YOU EVER FAILED TO COMPLETE A CONTRACT AWARDED TO YOU?
_____ YES _____ NO
IF YES, WHERE AND WHY?

- * 7. HAVE YOU EVER DEFAULTED ON A CONTRACT? _____ YES _____ NO
IF YES, PROVIDE DETAILS.

- * 8. LIST YOUR VEHICLES/EQUIPMENT AVAILABLE FOR THIS CONTRACT:

- * 9. IN THE SPACES FOLLOWING, PROVIDE INFORMATION REGARDING CONTRACTS COMPLETED BY YOUR FIRM SIMILAR IN NATURE TO THE PROJECT BEING BID. A MINIMUM OF FOUR (4) CONTRACTS SHALL BE LISTED. PUBLICLY BID CONTRACTS ARE PREFERRED, BUT NOT MANDATORY.

PROJECT NAME: _____
OWNER: _____
CITY/STATE: _____

DOLLAR AMOUNT: \$ _____ DATE COMPLETED: _____
PUBLICLY BID? _____ YES _____ NO
TYPE OF WORK?: _____
CONTACT PERSON: _____ TELEPHONE #: (____) _____
CONTACT PERSON'S RELATION TO PROJECT?: _____
(i.e., contract manager, purchasing agent, etc.)

PROJECT NAME: _____
OWNER: _____
CITY/STATE: _____
DOLLAR AMOUNT: \$ _____ DATE COMPLETED: _____
PUBLICLY BID? _____ YES _____ NO
TYPE OF WORK?: _____
CONTACT PERSON: _____ TELEPHONE #: (____) _____
CONTACT PERSON'S RELATION TO PROJECT?: _____
(i.e., contract manager, purchasing agent, etc.)

PROJECT NAME: _____
OWNER: _____
CITY/STATE: _____
DOLLAR AMOUNT: \$ _____ DATE COMPLETED: _____
PUBLICLY BID? _____ YES _____ NO
TYPE OF WORK?: _____
CONTACT PERSON: _____ TELEPHONE #: (____) _____
CONTACT PERSON'S RELATION TO PROJECT?: _____
(i.e., contract manager, purchasing agent, etc.)

PROJECT NAME: _____
OWNER: _____
CITY/STATE: _____
DOLLAR AMOUNT: \$ _____ DATE COMPLETED: _____
PUBLICLY BID? _____ YES _____ NO
TYPE OF WORK?: _____
CONTACT PERSON: _____ TELEPHONE #: (____) _____
CONTACT PERSON'S RELATION TO PROJECT?: _____
(i.e., contract manager, purchasing agent, etc.)

10. The undersigned certifies that the information contained herein is complete and accurate and hereby authorizes and requests any person, firm, or corporation to furnish any information requested by the City of Newton in verification of the recitals comprising this statement of Bidder's qualifications and experience.

DATE: _____ BIDDER: _____

SIGNATURE: _____

PRINTED NAME: _____ TITLE: _____

END OF SECTION

CERTIFICATE OF NON-COLLUSION

The undersigned certifies under penalties of perjury that this bid or proposal has been made and submitted in good faith and submitted in good faith and without collusion or fraud with any other person. As used in this certification, the word “person” shall mean any natural person, business, partnership, corporation, union, committee club, or other organization, entity, or group or individuals.

(Signature of individual)

Name of Business

CERTIFICATION OF TAX COMPLIANCE

Pursuant to M.G.L. c.62C, §49A and requirements of the City, the undersigned acting on behalf of the Contractor certifies under the penalties of perjury that the Contractor is in compliance with all laws of the Commonwealth relating to taxes including payment of all local taxes, fees, assessments, betterments and any other local or municipal charges (unless the Contractor has a pending abatement application or has entered into a payment agreement with the entity to which such charges were owed), reporting of employees and contractors, and withholding and remitting child support.*

**Signature of Individual (Mandatory)

*** Contractor's Social Security Number
(Voluntary) or Federal Identification Number

Print Name: _____

Date: _____

OR

Company Name
(Corporation, Partnership, LLC, etc.)

By: _____
**Corporate Officer (Mandatory)

Print Name: _____

Date: _____

- * The provision in this Certification relating to child support applies only when the Contractor is an individual.
- ** Approval of a contract or other agreement will not be granted until the City receives a signed copy of this Certification.
- *** Your social security number may be furnished to the Massachusetts Department of Revenue to determine whether you have met tax filing or tax payment obligations. Providers who fail to correct their non-filing or delinquency will not have a contract or other agreement issued, renewed, or extended.

CERTIFICATE OF FOREIGN CORPORATION

The undersigned hereby certifies that it has been duly established, organized, or chartered as a corporation under the laws of:

(Jurisdiction)

The undersigned further certifies that it has complied with the requirements of M.G.L. c. 30, §39L (if applicable) and with the requirements of M.G.L. c. 156D, §15.03 relative to the registration and operation of foreign corporations within the Commonwealth of Massachusetts.

Name of person signing proposal

Signature of person signing proposal

Name of Business (Please Print or Type)

Affix Corporate Seal here

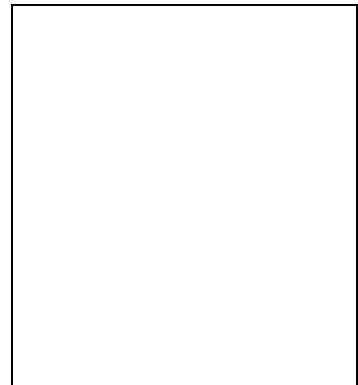

City of Newton



Mayor
Ruthanne Fuller

Purchasing Department

Nicholas Read *Chief Procurement Officer*
1000 Commonwealth Avenue
Newton Centre, MA 02459-1449
purchasing@newtonma.gov

Telephone
(617) 796-1220
Fax:
(617) 796-1227
TDD/TTY
(617) 796-1089

Date

Vendor

Re: Debarment Letter for Invitation For Bid #22-02

As a potential vendor on the above contract, the City requires that you provide a debarment/suspension certification indicating that you are in compliance with the below Federal Executive Order. Certification can be done by completing and signing this form.

Debarment:

Federal Executive Order (E.O.) 12549 “Debarment and Suspension“ requires that all contractors receiving individual awards, using federal funds, and all sub-recipients certify that the organization and its principals are not debarred, suspended, proposed for debarment, declared ineligible, or voluntarily excluded by any Federal department or agency from doing business with the Federal Government.

I hereby certify under pains and penalties of perjury that neither I nor any principal(s) of the Company identified below is presently debarred, suspended, proposed for debarment, declared ineligible, or voluntarily excluded from participation in this transaction by any federal department or agency.

PHONE _____ FAX _____
EMAIL _____

Signature

Date

If you have questions, please contact Nicholas Read, Chief Procurement Officer at (617) 796-1220.

Request for Taxpayer Identification Number and Certification

**Give form to the
requester. Do not
send to the IRS.**

Print or type See Specific instructions on page 2.	Name (as shown on your income tax return)	
	Business name, if different from above	
	Check appropriate box: <input type="checkbox"/> Individual/Sole proprietor <input type="checkbox"/> Corporation <input type="checkbox"/> Partnership <input type="checkbox"/> Limited liability company. Enter the tax classification (D=disregarded entity, C=corporation, P=partnership) ▶ <input checked="" type="checkbox"/> Exempt payee <input type="checkbox"/> Other (see instructions) ▶	
	Address (number, street, and apt. or suite no.)	Requester's name and address (optional)
	City, state, and ZIP code	
List account number(s) here (optional)		

Part I Taxpayer Identification Number (TIN)

Enter your TIN in the appropriate box. The TIN provided must match the name given on Line 1 to avoid backup withholding. For individuals, this is your social security number (SSN). However, for a resident alien, sole proprietor, or disregarded entity, see the Part I instructions on page 3. For other entities, it is your employer identification number (EIN). If you do not have a number, see *How to get a TIN* on page 3.

Note. If the account is in more than one name, see the chart on page 4 for guidelines on whose number to enter.

Social security number
or
Employer identification number

Part II Certification

Under penalties of perjury, I certify that:

1. The number shown on this form is my correct taxpayer identification number (or I am waiting for a number to be issued to me), and
2. I am not subject to backup withholding because: (a) I am exempt from backup withholding, or (b) I have not been notified by the Internal Revenue Service (IRS) that I am subject to backup withholding as a result of a failure to report all interest or dividends, or (c) the IRS has notified me that I am no longer subject to backup withholding, and
3. I am a U.S. citizen or other U.S. person (defined below).

Certification instructions. You must cross out item 2 above if you have been notified by the IRS that you are currently subject to backup withholding because you have failed to report all interest and dividends on your tax return. For real estate transactions, item 2 does not apply. For mortgage interest paid, acquisition or abandonment of secured property, cancellation of debt, contributions to an individual retirement arrangement (IRA), and generally, payments other than interest and dividends, you are not required to sign the Certification, but you must provide your correct TIN. See the instructions on page 4.

Sign Here	Signature of U.S. person ▶	Date ▶	Name
------------------	----------------------------	--------	------

General Instructions

Section references are to the Internal Revenue Code unless otherwise noted.

Purpose of Form

A person who is required to file an information return with the IRS must obtain your correct taxpayer identification number (TIN) to report, for example, income paid to you, real estate transactions, mortgage interest you paid, acquisition or abandonment of secured property, cancellation of debt, or contributions you made to an IRA.

Use Form W-9 only if you are a U.S. person (including a resident alien), to provide your correct TIN to the person requesting it (the requester) and, when applicable, to:

1. Certify that the TIN you are giving is correct (or you are waiting for a number to be issued),
2. Certify that you are not subject to backup withholding, or
3. Claim exemption from backup withholding if you are a U.S. exempt payee. If applicable, you are also certifying that as a U.S. person, your allocable share of any partnership income from a U.S. trade or business is not subject to the withholding tax on foreign partners' share of effectively connected income.

Note. If a requester gives you a form other than Form W-9 to request your TIN, you must use the requester's form if it is substantially similar to this Form W-9.

Definition of a U.S. person. For federal tax purposes, you are considered a U.S. person if you are:

- An individual who is a U.S. citizen or U.S. resident alien,
- A partnership, corporation, company, or association created or organized in the United States or under the laws of the United States,
- An estate (other than a foreign estate), or
- A domestic trust (as defined in Regulations section 301.7701-7).

Special rules for partnerships. Partnerships that conduct a trade or business in the United States are generally required to pay a withholding tax on any foreign partners' share of income from such business. Further, in certain cases where a Form W-9 has not been received, a partnership is required to presume that a partner is a foreign person, and pay the withholding tax. Therefore, if you are a U.S. person that is a partner in a partnership conducting a trade or business in the United States, provide Form W-9 to the partnership to establish your U.S. status and avoid withholding on your share of partnership income.

The person who gives Form W-9 to the partnership for purposes of establishing its U.S. status and avoiding withholding on its allocable share of net income from the partnership conducting a trade or business in the United States is in the following cases:

- The U.S. owner of a disregarded entity and not the entity,

CONTRACT FORMS

The awarded bidder will be required to complete and submit documents substantially similar in form to the following.

These forms may need to be modified on account of changed circumstances, and are provided for informational purposes only.

CITY - CONTRACTOR AGREEMENT

CONTRACT NO. C -XXXX

THIS AGREEMENT made this ___ day of _____ in the year Two Thousand and Twenty One by and between the CITY OF NEWTON, a municipal corporation organized and existing under the laws of the Commonwealth of Massachusetts, hereinafter referred to as the CITY, acting through its Chief Procurement Officer, but without personal liability to him, and hereinafter referred to as the CONTRACTOR.

The parties hereto for the considerations hereinafter set forth agree as follows:

ARTICLE 1. STATEMENT OF WORK. The Contractor shall furnish all labor, materials, and equipment and perform all work required in strict accordance with the Contract Documents for the following project:

PARKING METER REMOVAL, SIGNS, and BOLLARDS

ARTICLE 2. TIME OF COMPLETION. The Contractor shall commence work under this Contract on the date specified in the written notice of the City to proceed and shall fully complete all work hereunder within the time specified in the Summary of Work and Specific Work Requirements of the Project Manual. Time is of the essence with regard to this contract, and all work specified **shall be completed within two months** of the Contractor's receipt of a Notice to Proceed. Failure to complete within the time specified shall be subject to the assessment of liquidated damages in accordance with the provisions contained in the Project Manual.

ARTICLE 3. THE CONTRACT PRICE. The City shall pay the Contractor for the full and satisfactory performance of the Contract, in current funds a sum not to exceed:

ARTICLE 4. CONTRACT DOCUMENTS. The Contract Documents consist of the following documents which are either attached to this Agreement or are incorporated herein by reference:

- a. This CITY-CONTRACTOR Agreement;
- b. The City's Invitation For Bid #22-02 issued by the Purchasing Department;
- c. The Project Manual for: **PARKING METER REMOVAL, SIGNS, and BOLLARDS** including the Instructions to Bidders; General Conditions; Special Conditions; MWBE/AA Requirements, Wage Rate Requirements and Wage Rate Schedule(s) including any updated prevailing wage rate schedules if applicable; The Supplementary Special Conditions; General Requirements and Project Specifications; and Drawings, if included or referenced therein;
- d. Addenda Number(s) _____;
- e. The Bid Response of the CONTRACTOR submitted for this Project and accompanying documents and certifications;
- f. Certificate(s) of Insurance and surety bond(s) submitted by the CONTRACTOR in connection with this Project;
- g. Duly authorized and executed Amendments, Change Orders or Work Orders issued by the CITY after execution of this CITY-CONTRACTOR Agreement.

This CITY-CONTRACTOR Agreement, together with the other documents enumerated in this Article, constitute the entire Agreement between the CITY and the CONTRACTOR. The CONTRACTOR represents that its bid was made without condition, qualification or reservation of any kind, except upon the written acknowledgement and consent of the CITY.

ARTICLE 5. ALTERNATES. The following Alternates have been accepted and their costs are included in the Contract Price stated in Article 3 of this Agreement:

Alternates: N/A

ARTICLE 6. APPLICABLE STATUTES. All applicable federal, state and local laws and regulations are incorporated herein by reference and the Contractor agrees to comply with same.

IN WITNESS WHEREOF, the parties have caused this instrument to be executed under seal the day and year first above written.

CONTRACTOR

CITY OF NEWTON

By _____

By _____

Chief Procurement Officer

Print Name _____

Date _____

Title _____

By _____

Commissioner of Public Works

Date _____

Date _____

Affix Corporate Seal Here

Approved as to Legal Form and Character

Certified that City funds are available in the following account number:
7629E401-585220

By _____

Associate City Solicitor

Date _____

I further certify that the Mayor, or her designee, is authorized to execute contracts and approve change orders.

CONTRACT & BONDS ARE APPROVED

By _____

Comptroller of Accounts

By _____

Mayor or her designee

Date _____

Date _____

CERTIFICATE OF AUTHORITY - CORPORATE

1. I hereby certify that I am the Clerk/Secretary of _____
(insert full name of Corporation)
2. corporation, and that _____
(insert the name of officer who signed the **contract and bonds**.)
3. is the duly elected _____
(insert the title of the officer in line 2)
4. of said corporation, and that on _____
(insert a date that is **ON OR BEFORE** the date the officer signed the **contract and bonds**.)

at a duly authorized meeting of the Board of Directors of said corporation, at which all the directors were present or waived notice, it was voted that

5. _____ the _____
(insert **name** from line 2) (insert **title** from line 3)

of this corporation be and hereby is authorized to execute contracts and bonds in the name and on behalf of said corporation, and affix its Corporate Seal thereto, and such execution of any contract of obligation in this corporation's name and on its behalf, with or without the Corporate Seal, shall be valid and binding upon this corporation; and that the above vote has not been amended or rescinded and remains in full force and effect as of the date set forth below.

6. ATTEST: _____ *AFFIX CORPORATE SEAL HERE*
(Signature of **Clerk or Secretary**)*
7. Name: _____
(Please print or type name in line 6)*
8. Date: _____
(insert a date that is **ON OR AFTER** the date the officer signed the **contract and bonds**.)

* The name and signature inserted in lines 6 & 7 **must** be that of the **Clerk or Secretary** of the corporation.

CITY OF NEWTON, MASSACHUSETTS

PAYMENT BOND

Know All Men By These Presents:

That we, _____, as PRINCIPAL, and _____, as SURETY, are held and firmly bound unto the City of Newton as Oblige, in the sum of _____dollars (\$_____) to be paid to the Obligee, for which payments well and truly to be made, we bind ourselves, our respective heirs, executors, administrators, successors and assigns, jointly and severally, firmly by these presents.

Whereas, the said PRINCIPAL has made a contract with the Obligee, bearing the date of _____, 2021 for the construction of _____ in Newton, Massachusetts.
(Project Title)

Now, the conditions of this obligation are such that if the PRINCIPAL and all Sub-contractors under said contract shall pay for all labor performed or furnished and for all materials used or employed in said contract and in any and all duly authorized modifications, alterations, extensions of time, changes or additions to said contract that may hereafter be made, notice to the SURETY of such modifications, alterations, extensions of time, changes or additions being hereby waived, the foregoing to include any other purposes or items set out in, and to be subject to, provisions of M.G.L. c. 30, sec. 39A, and M.G.L. c. 149 sec. 29, as amended, then this obligation shall become null and void; otherwise it shall remain in full force, virtue and effect.

In Witness Whereof, the PRINCIPAL and SURETY have hereto set their hands and seals this ___day of____, 2021.

PRINCIPAL

SURETY

BY _____

BY _____

(SEAL)

(ATTORNEY-IN-FACT) (SEAL)

(Title)

ATTEST: _____

ATTEST: _____

CITY OF NEWTON
GENERAL CONDITIONS OF THE CONTRACT
FOR PUBLIC WORKS CONSTRUCTION

ARTICLE 1

Definitions

The word "Commissioner" shall mean the official duly authorized to act for the City of Newton in the execution of the work of this contract, acting directly or through properly authorized agents.

The word "Engineer," or "City Engineer," shall mean the City Engineer of the City of Newton, acting directly or through properly authorized agents, such agents acting within the scope of the particular duties entrusted to them.

The word "Contractor" shall mean the party or parties contracting to perform the work covered by this contract or his, or their, legal representatives, successors or assigns.

The word "Plans" shall mean plans, and all related drawings, diagrams, profiles and specifications referred to and included in the Project Manual for this contract.

The word "City" shall mean the City of Newton.

The word "Project" shall mean the services which are the subject of the Contract Documents.

The words "Subcontract" and "Subcontractor" shall refer to project contracts between the Contractor and a subcontractor, and the subcontractor thereunder.

The term "Substantial Completion" shall mean either that the work required by the contract has been completed except for the work having a contract price of less than one per cent of the then adjusted contract price, or substantially all of the work has been completed and opened to public use except for minor incomplete or unsatisfactory work items that do not materially impair the usefulness of the work required by the contract.

ARTICLE 2
Plans, Drawings, Profiles

1. The work shall be done in accordance with Plans referred to in Article 1 and such further working and detail plans, drawings and profiles as may be furnished from time to time by the Engineer. All said plans, general and detail, are to be deemed a part of this contract, and the said Plans, specifications and contract are to be considered together, so that any work mentioned in the contract, though not shown on the Plans, and any work shown on the Plans though not mentioned in the contract, is to be provided by the Contractor as a part of this contract. Figured dimensions are to prevail over scale. All things which in the opinion of the Engineer may fairly be inferred from the contract, Plans and specifications, are to be executed by the Contractor as a part of the contract; and the Engineer shall be sole judge as to whether detail plans, drawings and profiles conform to the Plans and the contract.

Discrepancy in Plans

2. The Contractor shall carefully examine all said Plans, profiles, drawings, specifications and orders; all figures, dimensions, lines, marks and scales thereof, and all directions of the Commissioner and the Engineer relating to the work, and conform to those in relation to which there is no doubt or discrepancy, but at once submit all cases of doubt or discrepancy to the Engineer for adjustment. Anything done on any part of the work for which special information or drawing should be procured, unless done in accordance with such information or drawing, or anything done in relation to which there is doubt or discrepancy, except in accordance with the adjustment thereof, or done in violation of law or public authority, is to be redone if the Commissioner shall so direct.

ARTICLE 3
Inspection

The Contractor in carrying on the contract shall conform to all determinations and directions of the Engineer relating to the proper interpretation of the Plans, , the fitness of persons employed on the work or the number thereof, or the suitability, amount, quality, and value of anything done or any materials used, and the Contractor shall permit the Commissioner and/or the Engineer and/or persons designated by them to enter upon the work and inspect the same at all times and in all places, and shall provide safe and convenient facilities for making such entry and inspection.

ARTICLE 4
Change in Plans and Work

The City, acting through the Commissioner and upon his written order only, from time to time given to the Contractor or his foreman, may change, increase or take away any part of the work, or change the specifications, Plans, drawings, form or materials thereof. Any deduction or addition thereto is to be allowed, or paid for at a price to be determined, within not more than 15 days of the completion of the change, by the City Engineer acting in the same capacity as an architect in a building contract as between City and Contractor. Any demand for addition or deduction must be made in writing to the City Engineer within seven (7) days of the time change was ordered.

ARTICLE 5
Time and Manner of Doing the Work

1. The Contractor shall begin work upon receipt of written Notice to Proceed. Once begun the work shall be carried out in a continuous and uninterrupted fashion with sufficient workforce and resources to assure completion by the date for completion established by the Contract Documents.

2. The Contractor shall carry on the work in accordance with the requirements of law and of all other public authorities, and to the satisfaction of the Commissioner; he shall give all notices, take out all permits, pay all charges and fees, give personal supervision to the work and keep thereon a competent foreman and sufficient employees, skilled in the several parts which are given them to do.

Maintenance of Travel

3. As applicable, the Contractor shall conduct his work so as to interfere as little as possible with public travel, and shall give property owners proper means of access to their property where existing access has been cut off by the work. The Contractor shall keep the streets open for through travel except where, in the opinion of the Commissioner, it is necessary to close the street. The continuous length of the street occupied for the work shall be kept as short as possible, and no part of the work shall be unnecessarily delayed. Wherever the Commissioner shall direct, trenches shall be bridged by the Contractor in a proper and secure manner so as not to interrupt travel. Free access shall be maintained at all times to all water gates, gas gates, and fire hydrants.

Abandonment of Work by Contractor

4. In the event the City Engineer certifies to the Commissioner that the work is not being so carried forward or if the Contractor at any time is not carrying on the work to the satisfaction of the Commissioner, or is not observing any of the provisions of the contract, or has abandoned the work, or become insolvent or assigned his property, the City, acting by the Commissioner and at his discretion, may, with or without notice to the Contractor, or advertising for doing the work, and by contract, day labor or otherwise, do any part of the work which the Contractor has failed to do or replace any part not done to the satisfaction of the Commissioner, or take possession of the work and complete the same, and in doing so may use any implements, machinery or materials on or about the work which are the property of the Contractor, charging the Contractor any excess cost for completing the work, which excess cost the Contractor agrees to pay.

ARTICLE 6

Compensation for Work

1. Subject to the provisions of Paragraph 10 of this Article, the price named in the proposal and accepted by the City shall be paid by the City and received by the Contractor as full compensation for furnishing materials and for use of tools, forms, machinery and other implements, and for labor in moving materials and executing all the work contemplated in this contract, also for loss or damage arising from delay however occasioned, or out of the nature of the work aforesaid or from the action of the elements, from floods, or from any unforeseen obstructions or difficulties which may be encountered in the prosecution of the same and for all risks of every description connected with the work and for well and faithfully completing the work in the proper manner and according to the plans and specifications and requirements of the Commissioner under them.

2. During the first week of each calendar month, the City Engineer shall cause all work done by the Contractor during the previous month to be measured and shall estimate the value thereof and, on or before the 10th of each month issue a certificate to the Commissioner of the measurements and the amount due the Contractor according to the terms of his contract.

3. The City shall pay the Contractor on approval of the Commissioner monthly on or before the 18th of each month for all work done during the preceding month according to the aforementioned certificate of the City Engineer, less 5 per cent of the amount of such work and less any amounts due the City by the Contractor.

Final and Substantial Completion

4. Upon substantial completion of the work required by the Contract, the Contractor must present to the City Engineer written certification that the work is substantially complete. Within 21 calendar days after such certification is presented, the City Engineer shall present to the Contractor either a written declaration that the work is substantially complete or an itemized list of incomplete or unsatisfactory work items sufficient to demonstrate that the work is not substantially complete. The City Engineer shall include with such itemized list a date by which the work items must be completed, which date may not be earlier than the date for substantial completion established in the Contract Documents. If the City Engineer does not respond as provided herein within 21 calendar days, then the date of the Contractor's certification shall become the date for effective declaration of substantial completion.

5. Within 15 calendar days after the effective declaration of substantial completion, the City Engineer shall send to the Contractor by certified mail, return receipt requested, a complete list of all incomplete or unsatisfactory work items. Unless delayed by causes beyond the Contractor's control, with an extension of time granted pursuant to Article 8, the Contractor must complete the work items within 45 calendar days after receipt of the list, or by the contractual completion date, whichever is later. If the contractor fails to complete the work within the required time the City may, notwithstanding other rights and remedies at its disposal, and upon seven days written notice to the Contractor terminate the contract and complete the incomplete or unsatisfactory work items and charge the cost of same to the Contractor.

6. Within 65 calendar days following the effective declaration of substantial completion, the City Engineer shall issue to the Commissioner who shall cause to be paid to the Contractor a substantial completion estimate which estimate shall consist of the balance of the then current contract price less a one percent retention, the estimated cost to complete incomplete or unsatisfactory work items, the value of any outstanding claims against the Contractor and the sum of all demands for direct payment made pursuant to Article 12 herein, provided that until final acceptance, the City shall retain five percent of the value of all items planted in the ground.

7. The Contractor shall provide written notice to the City Engineer when the work has been brought to final completion. Within ten days following receipt of such notice, and providing his inspection shows no work items remain incomplete or unsatisfactory, the City Engineer shall issue to the Commissioner a final certificate of the total amount of work done and the money due the Contractor therefor, crediting thereon the amounts of the previous payments. In making the final certificate, the City Engineer shall not be bound by any preceding certificate or estimate of the amount of work done or materials furnished.

8. Within 30 calendar days following receipt of final completion, the City shall pay the Contractor, on the approval of the Commissioner, the percentages retained and the balance due the Contractor according to the aforementioned final certificate of the City Engineer less any indebtedness of the Contractor for incomplete or unsatisfactory work or claims made by or against the City. If a claim or claims are made, or notice of liability given, such amounts due the Contractor may be paid upon satisfaction of such claims or upon furnishing of indemnity to said City against all loss, cost, damage or expense by reason of such claims.

9. The City, on making any payment after the completion of the work, shall be released from all claim or liability to the Contractor for anything done or used, or for any loss or injury sustained in carrying on the contract, or for any act, omission, neglect or mistake of the City or any person relating to or affecting the contract, except for the balance of any sum retained as aforesaid.

Extra Work

10. The Contractor shall be paid for any additions, or deductions as provided in Article 4, paragraph 1, and for extra labor done by, and for extra materials furnished by him in compliance with the written order only of the Commissioner, calling for work not similar in character to that covered by the items given in the proposal, and for which no price is set in the said written order, the direct (not including consequential) cost to the Contractor, as determined to be reasonable by the Commissioner, plus fifteen per cent of said costs as so determined in regard to labor only. For teams or trucks so furnished, no payment shall be made to the Contractor beyond the current local rate as determined by the Commissioner in each case. The direct cost of labor may include the cost of mechanics and laborers furnished and a reasonable proportion of the time of the foreman and timekeeper, but it shall in no case include any charge for the use of tools, for establishment charges or for time spent by the Contractor. The actual cost of insurance on extra pay rolls and of materials furnished for extra work, shall be paid without any addition. The labor and materials so ordered shall constitute a part of the work to be done under the contract; and all and singular the provisions of the contract shall apply to said labor and materials as if the same were specified therein. The Contractor shall have no claim for the above mentioned extra labor and materials unless he furnishes the details and bills therefor within one week after doing any such labor or furnishing any such materials.

11. No claim of the Contractor against the City under this contract shall be deemed valid unless such claim is presented to the Commissioner within ten days from the time when the Contractor first knows of, or has opportunity to know of, the acts and circumstances on which such claim is based.

12. A payment or payments to the Contractor, in cases where these provisions or any of them, are not complied with, shall not be construed as a waiver of said provisions or any part thereof.

Contract Made Subject to Appropriations

13. This contract is made subject to appropriation heretofore made and shall not be altered unless the Contractor, the sureties on the bond, if any, the officer making the contract and the Mayor shall in writing agree thereto.

ARTICLE 7

Liquidated Damages

1. In case the work embraced in the contract shall not have been substantially completed by the date(s) stipulated therein, the Contractor shall pay to the City of Newton as liquidated damages a designated sum per calendar day for the entire period of overrun until the work is substantially completed in accordance with the following Schedule of Deductions and, in addition, the Contractor shall pay without reimbursement the entire cost of all traffic officers, railroad flagmen, inspectors, or other personnel the City Engineer and/or the Chief Engineer of the railroad determines to be necessary during the period of overrun of time.

SCHEDULE OF DEDUCTIONS

<u>Original Contract Amount From More Than</u>	<u>To and Including</u>	<u>Daily Charge Per Calendar Day</u>
\$ 0.	\$ 25,000.	\$ 30.
25,000.	50,000.	50.
50,000.	100,000.	100.
500,000.	1,000,000.	150.
1,000,000.	2,000,000.	200.
2,000,000.	—	300.

2. In case the work covered by the contract shall not have been brought to final completion within 45 calendar days following the date of declaration of substantial completion, the Contractor shall pay to the City of Newton as liquidated damages the sum of \$150.00 for each week or portion thereof during the period of overrun until the work is complete.

3. Whatever sum of money may become due and payable to the City of Newton by the Contractor under this Article may be retained out of money belonging or owed to the Contractor in the hands and possession of or by the City of Newton. It is agreed that this Article shall be construed and treated by the parties to the contract not as imposing a penalty upon said Contractor for failing fully to complete said work as agreed on or before the time specified in the proposal, but as liquidated damages to compensate said City of Newton for all additional costs incurred by it because of the failure of the Contractor fully to complete said work on or before the date of completion specified in the proposal.

ARTICLE 8

Delays and Extensions of Time

1. If the Contractor is delayed at any time in the progress of the work by an act or neglect of the City, or by changes in the work ordered by the City, or by unseasonably inclement weather, or by other causes deemed by the City Engineer to be beyond the Contractor's control, and which the City Engineer determines may justify delay, then the time for completion may be extended for such reasonable time as the City Engineer may determine.

2. No such extension of time will be allowed unless the Contractor submits a written request for an extension to the City Engineer no later than 10 calendar days of the start of the occurrence or event giving rise thereto. Each such request must describe the occurrence or event and specify the manner and extent that such occurrence or event is causing or has caused a delay in the work. The City Engineer shall promptly investigate each request and make his written determination to the Commissioner and the Contractor within 10 days after receipt of the request. In his determination the City Engineer may either grant, deny, or modify the length of the requested extension.

3. If the City Engineer's determination so warrants, the Commissioner shall authorize a written Change Order to the Contract extending the time for completion. No extension of time shall be deemed as granted until said Change Order has been duly executed by the parties.

4. Change Orders which may be executed by the City and the Contractor in connection with additions, extra labor and/or extra materials shall not be considered as allowing extensions of the time for completion unless the change order expressly specifies that additional time is allowed in connection with the work under the change order. Once a Change Order has been executed by the parties, any request by the Contractor for an extension of time based solely on the fact that additions, extra labor and/or extra materials are required by the Change Order will be denied by the City Engineer.

5. Permitting the Contractor to continue and finish the work or any part of it after the times fixed for its completion, or after the date to which the time for completion may have been extended, shall in no way operate as a waiver on the part of the City of Newton of any of its rights under the contract. The Contractor remains liable for damages caused other than by delay.

ARTICLE 9

Field Engineering

The Contractor shall retain a Registered Land Surveyor who shall furnish such boards and stakes and cause to be placed thereon, such lines, markers and directions relating to the work as the Commissioner or City Engineer shall from time to time direct.

1.01 SECTION INCLUDES

- A. Survey work and other field engineering responsibilities of the Contractor.

1.02 REQUIREMENTS

- A. The Contractor shall be responsible for field survey, layout of the work, and the establishing of lines and grades for his use.
- B. Layout and set all lines, levels, grades, elevations, reference marks, batter boards and measurements required for the construction of the Work. Verify such marks by instrument to confirm accuracy. The Engineer shall provide information on the baseline and elevation control available.
- C. Locate and protect established horizontal and vertical survey control and reference points, benchmarks and stone bounds.
- D. Make, check, and be responsible for all measurements and dimensions necessary for the proper horizontal and vertical layout and construction of the Work.
- E. Locate and protect existing street right of way, bounds and property bounds.
- F. Verify location and reset (if needed) street right-of-way bounds and markers by a Professional Land Surveyor (PLS) as per the Contract Documents.
- G. All staking shall be directed and performed by qualified engineering or surveying personnel who are trained, experienced and skilled in construction layout of the type required under this contract. The contractor shall submit the qualifications of the survey personnel to the Owner for review and approval.

The Owner reserves the right to evaluate the performance of the survey personnel during the course of the work and require the replacement of personnel whose work, in the judgement of the Owner, is unsatisfactory.

- H. The Engineer will be permitted to check the lines, elevations, reference marks, batter boards, etc., set by the Contractor. The Contractor shall correct any errors found in lines, elevations, reference marks, batter boards, etc. Such a check shall not be construed as approval of the Contractor's work and shall not relieve or diminish the responsibility of the Contractor for the accurate construction and completion of the Work in compliance with the Contract Documents.
- I. The Contractor is to make a video tape and/or photographic record of all existing sideline conditions, prior to the commencement of construction activities, and/or as may be required as the construction activities progress, for the purpose of documenting all decrepit, and/or extraordinary points of concern. All video and picture making shall be done on foot and shall not be 'shot' from a vehicle. This video record shall be made by the Contractor and a copy, or a secondary video tape, shall be delivered to the Engineer. A representative from the Engineering Division shall present at the time of the recording.

ARTICLE 10

Public Service Pipes and Conduits

1. The Contractor shall maintain such pipes or conduits of public service corporations or of the City as are across or within the lines of the work until such time as said public service corporations or the City assume the maintenance or removal of said pipes or conduits. The Commissioner will notify such public service corporations to that effect on the existence of such obstructions to the work being brought to his notice by the Contractor. The City will relocate either temporarily or permanently all water mains and water service pipes, or hydrants, and drains or sewers which may interfere with the work contemplated in this contract. (This clause is not to be construed as applying to such pipes as may be readily supported and protected during the progress of the work.) The cost of shutting off and turning on water in water mains during blasting shall be assumed by the City.

Protection of Existing Structures

2. All existing gas pipes, water pipes, sewers, drains, conduits, or other structures which are uncovered by the excavation shall be carefully supported and protected from injury by the Contractor, and, in case of injury, they shall be restored by him, without compensation therefor, to as good condition as that in which they were found, and shall be kept in repair until 6 months after the completion of the work. The Contractor shall provide suitable temporary channels for water at all water courses. Wherever the work passes under or adjacent to street railway tracks, the Contractor shall make all necessary arrangements with the railway company for doing any work which may affect the property of the company or interfere with the operating of the railway, and he shall be liable for any damage that may be caused by any act, omission or neglect on his part, and shall pay all expenses of every kind incidental to this work.

Changing the Location of Existing Structures

3. Whenever it becomes necessary to change the location of any water or gas pipes, sewers, drains, conduits or other structures not otherwise provided for in these specifications, the Contractor shall do the whole or such portions of the work of making such changes as the Commissioner may require, and shall receive in payment therefor the reasonable cost of the work done as determined by the Commissioner plus 15 per cent of such cost. In estimating such cost, no allowance shall be made to the Contractor for the use of tools not especially provided for this work, for general superintendence, or for any overhead expenses except liability insurance.

ARTICLE 11

Co-operation with Other Contractors

The Contractor shall conduct the work in such manner as not to interfere with other work being done by the City, by contract or otherwise, and if deemed necessary by the Commissioner, the work under this contract shall conform to the progress of said other work; shall co-operate with other contractors or employees who may be doing work for the City, and with public service corporations affected by the work, in arranging for storage places, connections, bracings, temporary support for structures, repairs, etc.

ARTICLE 12

Subcontracts

1. The Contractor, in any contract with a Subcontractor, shall provide that the Subcontractor shall be subject to all specifications, terms, provisions, conditions, requirements and liabilities set forth in this contract so far as such specifications, terms, provisions, conditions, requirements and liabilities are applicable to the work to be done under such Subcontract, and shall also provide that such Subcontract shall be terminated by the Contractor whenever the Commissioner shall certify to him in writing that in his opinion the work of the Subcontractor is unnecessarily or unreasonably delayed or that the Subcontractor has violated any of the provisions of this contract. The Contractor shall at once terminate such subcontract if the Commissioner, after certifying as aforesaid, shall in writing direct the Contractor to make such termination.

2. Subcontracts shall be made in writing and the Contractor shall furnish the Commissioner with a copy of all Subcontracts on demand.

3. Pursuant to the provisions of M.G.L. Ch. 30, Sec. 39F (1), the following provisions are included in the General Conditions:

(a) Forthwith after the Contractor receives payment on account of a periodic estimate, the Contractor shall pay to each Subcontractor the amount paid for the labor performed and the materials furnished by that Subcontractor, less any amount specified in any court proceedings barring such payment and also less any amount claimed due from the Subcontractor by the Contractor.

(b) Not later than the sixty-fifth day after each Subcontractor substantially completes his work in accordance with the plans and specifications, the entire balance due under the Subcontract less amounts retained by the City as the estimated cost of completing the incomplete and unsatisfactory items of work, shall be due the Subcontractor; and the City shall pay that amount to the Contractor. The Contractor shall forthwith pay to the Subcontractor the full amount received from the City less any amount specified in any court proceedings barring the payment and also less any amount claimed due from the Subcontractor by the Contractor.

(c) Each payment made by the City to the Contractor pursuant to subparagraphs (a) and (b) of this paragraph for the labor performed and the materials furnished by a Subcontractor shall be made to the Contractor for the account of the Subcontractor; and the City shall take reasonable steps to compel the Contractor to make each such payment to each such Subcontractor. If the City has received a demand for direct payment from a Subcontractor for any amount which has already been included in a payment to the Contractor or which is to be included in a payment to the Contractor for payment to the Subcontractor as provided in subparagraphs (a) and (b), the City shall act upon the demand as provided in this section.

(d) If, within seventy days after the Subcontractor has substantially completed the Subcontract work, the Subcontractor has not received from the Contractor the balance due under the Subcontract including any amount due for extra labor and materials furnished to the Contractor, less any amount retained by the City, the demand shall be by a sworn statement delivered to or sent by certified mail to the City, and a copy shall be delivered to or sent by certified mail to the Contractor at the same time. The demand shall contain a detailed breakdown of the balance due under the Subcontract and also a statement of the status of the completion of the Subcontract work shall be valid even if delivered or mailed prior to the seventieth day after which the Subcontractor has substantially completed the Subcontract work. Within ten days after the Subcontractor has delivered or so mailed the demand to the City and delivered or so mailed a copy to the Contractor, the Contractor may reply to the demand. The reply shall be by a sworn statement delivered to or sent by certified mail to the City and a copy shall be delivered to or sent by certified mail to the Subcontractor at the same time. The reply shall contain a detailed breakdown of the balance due under the Subcontract including any amount due for extra labor and materials furnished to the Contractor and of the amount due for each claim made by the Contractor against the Subcontractor.

(e) Within fifteen days after receipt of the demand by the City, but in no event prior to the seventieth day after substantial completion of the Subcontract work, the City shall make direct payment to the Subcontractor of the balance due under the Subcontract including any amount due for extra labor and materials furnished to the Contractor, less any amount (i) retained by the City as the estimated cost of completing the incomplete or unsatisfactory items of work (ii) specified in any court proceedings barring such payment, or, (iii) if the reply shall not deduct from a direct payment any amount as provided in part (iii) if the reply is not sworn to, or for which the sworn reply does not contain the detailed breakdown required by subparagraph (d). The City shall make further direct payments to the Subcontractor forthwith after the removal of the basis for deductions from direct payments made as provided in parts (i) and (ii) of this subparagraph.

(f) The City shall forthwith deposit the amount deducted from a direct payment as provided in part (iii) of subparagraph (e) in an interest-bearing joint account in the names of the Contractor and the Subcontractor in a bank in Massachusetts selected by the City or agreed upon by the Contractor and the Subcontractor and shall notify the Contractor and the Subcontractor of the date of the deposit and the bank receiving the deposit. The bank shall pay the amount in the account, including accrued interest, as provided in an agreement between the Contractor and the Subcontractor or as determined by decree of a court of competent jurisdiction.

(g) All direct payments and all deductions from demands for direct payments deposited in an interest-bearing account or accounts in a bank pursuant to subparagraph (f) shall be made out of amounts payable to the Contractor at the time of receipt of a demand for direct payment from a Subcontractor and out of amounts which later become payable to the Contractor and in the order of receipt of such demands from Subcontractors. All direct payments shall discharge the obligation of the City to the Contractor to the extent of such payment.

(h) The City shall deduct from payments to a Contractor amounts which, together with deposits in interest-bearing accounts pursuant to subparagraph (f), are sufficient to satisfy all unpaid balances of demands for direct payment received from Subcontractors. All such amounts shall be earmarked for such direct payments, and the Subcontractors shall have a right in such deductions prior to any claims against such amounts by creditors of the Contractor.

(i) The Contractor shall notify the Engineer, as soon as practicable after execution of the Contract, the name and address of each Subcontractor he intends to employ, the portion of the work which the Subcontractor is to do, and such other information the Engineer may require in order to ascertain whether the Subcontractor is reliable and able to perform the work.

ARTICLE 13 **Responsibility for Work-Contractor's Responsibility**

The Contractor has made his proposal from his own examinations and estimates, and shall not hold the City, its agents, or employees, responsible for or bound by, any schedule, estimate, sounding, boring, or any plan of any part of the work; shall, if any error in any plan, drawing, specification or direction relating to anything to be done under the contract come to his knowledge, report it at once to the Commissioner; shall not, except as the Commissioner shall authorize in writing, assign or sublet any part of the contract except for the supply of materials and plant, or of anything to be done thereunder; shall, subject to the provisions of the contract take all responsibility of, and bear all losses resulting to him in carrying on the contract, and shall assume the defense of, and hold the City, its agents and employees harmless from all suits and claims against them, or any of them, arising from the use of any invention, patent or patent right, material, labor or implement, by or from any act or omission or neglect of the Contractor, his Subcontractor, his agents or employees, in carrying on the contract, or for any liability of any nature arising under the contract. The Contractor shall be solely responsible and liable for, and shall fully protect and indemnify the City against all claims for damages to persons or property occasioned by or resulting from blasting or other methods or processes in the work of construction, whether such damages be attributable to negligence of the Contractor, his employees or his Subcontractor or otherwise.

ARTICLE 14 **LIGHTS--GUARDS**

1. The Contractor shall assume all responsibilities of the work and take all proper precautions to protect persons and property from injury and unnecessary interference; leave a reasonably unobstructed way along public and private places for pedestrians, teams, and vehicles, and for access to hydrants; provide proper walks over or around any obstruction made in a public or private place in carrying on the contract, and maintain from the beginning of twilight through the whole of every night, on or near the obstruction sufficient lights and guards to protect travelers from injury thereby, and if, after one notification from the Commissioner that said lights and guards are not sufficient, the Contractor has not placed additional lights and guards to the satisfaction of the Commissioner, the Commissioner shall have the right to take charge of that part of the work at the expense of the Contractor. While the work is suspended he shall keep all roadways and sidewalks in proper condition, and when the work is completed put the place and vicinity in proper condition and so leave them.

2. The Contractor shall provide proper means of access to property where the existing access is cut off by the Contractor and replace or put in good condition every conduit, catch-basin, tree, wall, fence, or other thing injured by the Contractor in carrying on the contract, unless the same has been permanently done away with, on approval of the Commissioner, as being necessary to the proper carrying on of the contract.

ARTICLE 15 **Guaranty**

1. Any settlement or other defect, or the failure of any part of the structure or the work due to defective materials or workmanship, that occurs within one year after the work is completed, is to be immediately repaired by the Contractor. In the event of any such settlement, defect, or failure causing liability to the City for damage to persons or property, the Contractor does by this clause agree to hold the City harmless and to assume the defense of any claims therefor.

2. Responsibility under this guaranty for the adequacy of the work does not relieve the Contractor of his obligation to comply with the terms of the contract and to conform to all the requirements of the plans and specifications, nor does it give him the right to deviate in any way from the details of design of the structure or the work.

ARTICLE 16
Defective Work and Materials

The inspection of the work shall not relieve the Contractor of any of his obligations to fulfill his contract as herein described, and defective work shall be made good and unsuitable materials may be rejected, notwithstanding that such work and materials have been previously overlooked by the Engineer and accepted or estimated for payment. If the work or materials, or any part thereof shall be found defective at any time before the final acceptance of the whole work, the Contractor shall forthwith make good such defect in a manner satisfactory to the Engineer, and if any material brought upon the ground for use in the work or selected for the same, shall be condemned by the Engineer as unsuitable or not in conformity with the specifications, the Contractor shall forthwith remove such materials from the vicinity of the work. Nothing in this contract shall be construed as vesting in the Contractor any right of property in the materials used after they have been attached or affixed to the work or the soil, but all materials shall, upon being so attached or affixed, become the property of the City.

ARTICLE 17
Employment of Labor

The Contractor shall give preference in employment, first to citizens of Massachusetts, second, to other citizens of the United States; and shall allow all employees on said work to lodge, board and trade where they choose, and shall not obstruct any other person in doing work for the City; and shall conform to all labor laws of the Commonwealth; and no laborer or teamster, workman or mechanic working within this Commonwealth in the employ of the Contractor or Subcontractor or other person doing or contracting to do the whole or a part of the work contemplated by the Contractor shall be requested to, or required to, or work more than eight hours in any one calendar day. This contract is subject to all the laws of the Commonwealth, and ordinances of the City and if any clause thereof does not conform to such laws and ordinances, such clause shall be void and such laws and ordinances operated in lieu thereof.

ARTICLE 18
Laws and Regulations - Contractor to Comply with Law

The Contractor shall keep fully informed of all existing or future acts of the legislature, and of all municipal ordinances, prohibitions, rules and regulations in any manner affecting the conduct of the work, and of all orders or decrees of any body or tribunal having any jurisdiction or authority over the materials, times, places and actions of those employed in the work embraced in the contract. The Contractor shall at all times observe and comply with all existing and future acts, ordinances, prohibitions, rules, regulations, orders and decrees; and shall protect and indemnify the city and its employees against any and all claims arising from or based on any violation of such acts, ordinances, prohibitions, rules, regulations, orders or decrees, and against all violations of law by the Contractor or his agents or employees.

END OF SECTION

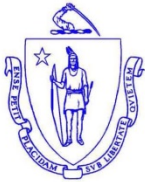

THE COMMONWEALTH OF MASSACHUSETTS
DEPARTMENT OF LABOR
DIVISION OF OCCUPATIONAL SAFETY
PREVAILING WAGE PROGRAM
www.mass.gov/dos/pw

NOTICE: TO AWARDING AUTHORITIES AND CONTRACTORS

ISSUED: SEPTEMBER 1, 2006

DRIVERS WHO HAUL BITUMINOUS CONCRETE (ASPHALT)

The Massachusetts Supreme Judicial Court recently affirmed that drivers who haul bituminous concrete to public construction projects are not covered by the Prevailing Wage Law while off-site, including time spent over-the-road and picking-up materials. These drivers are covered by the Prevailing Wage Law only while on-site at the public construction project.

In Teamsters Joint Council No. 10 v. Department of Labor, et al., 447 Mass. 100 (2006), the SJC upheld a 2001 administrative decision limiting the applicability of prevailing wage rates to the time bituminous drivers spend at the public construction site. This most recent decision of the SJC followed a 1989 ruling that had upheld an earlier Department of Labor (and Industries') policy that had deemed this category of drivers to be "teamsters" under the Law and, therefore, entitled to prevailing wage rates. See Construction Industries of Massachusetts v. Commissioner of Labor and Industries, 406 Mass. 162 (1989). However, the earlier court case had left open the question of whether this entitled these bituminous drivers to prevailing wage rates for their over-the-road time as well as their on-site time. This most recent decision has now answered that question.

All of the requirements of the Prevailing Wage Law, including certified weekly payroll requirements, apply to bituminous drivers for all time spent at the public construction site.

DRIVERS WHO HAUL READY-MIX CONCRETE (CEMENT)

Drivers who haul ready-mix concrete to public construction projects are not covered by the Prevailing Wage Law while off-site, including time spent over-the-road and picking-up materials. These drivers are covered by the Prevailing Wage Law while on-site at the public construction project. This applicability determination was established by a 2001 administrative decision of the Department of Labor's Division of Occupational Safety.

All of the requirements of the Prevailing Wage Law, including certified weekly payroll requirements, apply to ready-mix drivers for all time spent at the public construction site.

Please feel free to contact the Division of Occupational Safety at 617-626-6953 if you have any questions. Questions about enforcement of the Prevailing Wage Law may be directed to the Attorney General's Fair Labor and Business Practices Division at 617-727-3465

CITY OF NEWTON

WAGE RATE REQUIREMENTS

1. GENERAL

- A. This section summarizes the requirements for the payment of wages to laborers and mechanics employed under the Contract.
- B. Other duties and requirements of law which may not be specified in this section apply and are inherently a part of the Contract.

2. WAGE RATES

- A. The rate per hour to be paid to mechanics, apprentices, teamsters, chauffeurs, and laborers employed on the Work shall not be less than the rate of wages in the attached "Minimum Wage Rates" as determined by the Commissioner of Labor and Industries. This schedule shall continue to be the minimum rate of wages for said employees during the life of this Contract.
- B. Keep posted on the site a legible copy of said schedule. Keep on file the wage rates and classifications of labor employed on this Work in order that they may be available for inspection by the Owner, Administrator, or the Architect.
- C. Apprentices employed pursuant to this determination of wage rates must be registered and approved by the State Apprenticeship Council wherever rates for journeymen or apprentices are not listed.
- D. Pay reserve police officers employed on the Work the prevailing rate of wages paid to regular police officers as required by M.G.L. c149, Sec. 34B, as amended. Such police officers shall be covered by Workmen's Compensation Insurance and Employers Liability Insurance by the Contractor.
- E. **The Contractor and all subcontractors shall, on a weekly basis throughout the term of the contract, provide to the City of Newton certified payroll affidavits verifying compliance with M.G.L. c.149, Sec. 27, 27A and 27B.** The Contractor is obligated to provide such records to the City directly on a weekly basis. The City may assess a penalty of \$100 for each day beyond the required submission date that such records are received, which amount shall be deducted from any amounts to the Contractor from the City. In the event of chronic late submissions, the City shall report the same to the Office of the Attorney General.
- F. The Contractor and all subcontractors shall provide a Statement of Compliance within 15 days of the completion of its portion of the work. This statement shall be submitted to the Owner on the form found elsewhere in this section.
- G. The Contractor shall maintain accurate and complete records, including payroll records, during the Contract term and for three years thereafter.

END OF SECTION



CHARLES D. BAKER
Governor

KARYN E. POLITO
Lt. Governor

THE COMMONWEALTH OF MASSACHUSETTS
EXECUTIVE OFFICE OF LABOR AND WORKFORCE DEVELOPMENT
DEPARTMENT OF LABOR STANDARDS

Prevailing Wage Rates

As determined by the Director under the provisions of the
Massachusetts General Laws, Chapter 149, Sections 26 to 27H

ROSALIN ACOSTA
Secretary
MICHAEL FLANAGAN
Director

Awarding Authority: City of Newton
Contract Number: IFB 22-02 **City/Town:** NEWTON
Description of Work: Parking Meter Removal, Signs & Bollards; removal of parking meters and installation of bollards and signs.

Job Location: Various locations

Information about Prevailing Wage Schedules for Awarding Authorities and Contractors

- This wage schedule applies only to the specific project referenced at the top of this page and uniquely identified by the "Wage Request Number" on all pages of this schedule.
 - An Awarding Authority must request an updated wage schedule from the Department of Labor Standards ("DLS") if it has not opened bids or selected a contractor within 90 days of the date of issuance of the wage schedule. For CM AT RISK projects (bid pursuant to G.L. c.149A), the earlier of: (a) the execution date of the GMP Amendment, or (b) the bid for the first construction scope of work must be within 90-days of the wage schedule issuance date.
 - The wage schedule shall be incorporated in any advertisement or call for bids for the project as required by M.G.L. c. 149, § 27. The wage schedule shall be made a part of the contract awarded for the project. The wage schedule must be posted in a conspicuous place at the work site for the life of the project in accordance with M.G.L. c. 149 § 27. The wages listed on the wage schedule must be paid to employees performing construction work on the project whether they are employed by the prime contractor, a filed sub-bidder, or any sub-contractor.
 - All apprentices working on the project are required to be registered with the Massachusetts Department of Labor Standards, Division of Apprentice Standards (DLS/DAS). Apprentice must keep his/her apprentice identification card on his/her person during all work hours on the project. An apprentice registered with DAS may be paid the lower apprentice wage rate at the applicable step as provided on the prevailing wage schedule. **Any apprentice not registered with DLS/DAS regardless of whether or not they are registered with any other federal, state, local, or private agency must be paid the journeyworker's rate for the trade.**
 - The wage rates will remain in effect for the duration of the project, except in the case of multi-year public construction projects. For construction projects lasting longer than one year, awarding authorities must request an updated wage schedule. Awarding authorities are required to request these updates no later than two weeks before the anniversary of the date the contract was executed by the awarding authority and the general contractor. For multi-year CM AT RISK projects, awarding authority must request an annual update no later than two weeks before the anniversary date, determined as the earlier of: (a) the execution date of the GMP Amendment, or (b) the execution date of the first amendment to permit procurement of construction services. Contractors are required to obtain the wage schedules from awarding authorities, and to pay no less than these rates to covered workers. The annual update requirement is not applicable to 27F "rental of equipment" contracts.
 - Every contractor or subcontractor which performs construction work on the project is required to submit weekly payroll reports and a Statement of Compliance directly to the awarding authority by mail or email and keep them on file for three years. Each weekly payroll report must contain: the employee's name, address, occupational classification, hours worked, and wages paid. Do not submit weekly payroll reports to DLS. A sample of a payroll reporting form may be obtained at <http://www.mass.gov/dols/pw>.
 - Contractors with questions about the wage rates or classifications included on the wage schedule have an affirmative obligation to inquire with DLS at (617) 626-6953.
 - Employees not receiving the prevailing wage rate set forth on the wage schedule may report the violation to the Fair Labor Division of the office of the Attorney General at (617) 727-3465.
 - Failure of a contractor or subcontractor to pay the prevailing wage rates listed on the wage schedule to all employees who perform construction work on the project is a violation of the law and subjects the contractor or subcontractor to civil and criminal penalties.
-

Classification	Effective Date	Base Wage	Health	Pension	Supplemental Unemployment	Total Rate
Construction						
(2 AXLE) DRIVER - EQUIPMENT <i>TEAMSTERS JOINT COUNCIL NO. 10 ZONE A</i>	06/01/2021	\$37.05	\$12.91	\$14.82	\$0.00	\$64.78
	08/01/2021	\$37.05	\$13.41	\$14.82	\$0.00	\$65.28
	12/01/2021	\$37.05	\$13.41	\$16.01	\$0.00	\$66.47
(3 AXLE) DRIVER - EQUIPMENT <i>TEAMSTERS JOINT COUNCIL NO. 10 ZONE A</i>	06/01/2021	\$37.12	\$12.91	\$14.82	\$0.00	\$64.85
	08/01/2021	\$37.12	\$13.41	\$14.82	\$0.00	\$65.35
	12/01/2021	\$37.12	\$13.41	\$16.01	\$0.00	\$66.54
(4 & 5 AXLE) DRIVER - EQUIPMENT <i>TEAMSTERS JOINT COUNCIL NO. 10 ZONE A</i>	06/01/2021	\$37.24	\$12.91	\$14.82	\$0.00	\$64.97
	08/01/2021	\$37.24	\$13.41	\$14.82	\$0.00	\$65.47
	12/01/2021	\$37.24	\$13.41	\$16.01	\$0.00	\$66.66
ADS/SUBMERSIBLE PILOT <i>PILE DRIVER LOCAL 56 (ZONE 1)</i>	08/01/2020	\$103.05	\$9.40	\$23.12	\$0.00	\$135.57
For apprentice rates see "Apprentice- PILE DRIVER"						
AIR TRACK OPERATOR <i>LABORERS - ZONE 1</i>	06/01/2021	\$41.42	\$8.60	\$17.57	\$0.00	\$67.59
	12/01/2021	\$42.43	\$8.60	\$17.57	\$0.00	\$68.60
	06/01/2022	\$43.43	\$8.60	\$17.57	\$0.00	\$69.60
	12/01/2022	\$44.43	\$8.60	\$17.57	\$0.00	\$70.60
	06/01/2023	\$45.43	\$8.60	\$17.57	\$0.00	\$71.60
	12/01/2023	\$46.68	\$8.60	\$17.57	\$0.00	\$72.85
For apprentice rates see "Apprentice- LABORER"						
AIR TRACK OPERATOR (HEAVY & HIGHWAY) <i>LABORERS - ZONE 1 (HEAVY & HIGHWAY)</i>	06/01/2021	\$41.42	\$8.60	\$17.57	\$0.00	\$67.59
	12/01/2021	\$42.43	\$8.60	\$17.57	\$0.00	\$68.60
For apprentice rates see "Apprentice- LABORER (Heavy and Highway)"						
ASBESTOS REMOVER - PIPE / MECH. EQUIPT. <i>HEAT & FROST INSULATORS LOCAL 6 (BOSTON)</i>	12/01/2020	\$38.10	\$12.80	\$9.45	\$0.00	\$60.35
ASPHALT RAKER <i>LABORERS - ZONE 1</i>	06/01/2021	\$40.92	\$8.60	\$17.57	\$0.00	\$67.09
	12/01/2021	\$41.93	\$8.60	\$17.57	\$0.00	\$68.10
	06/01/2022	\$42.93	\$8.60	\$17.57	\$0.00	\$69.10
	12/01/2022	\$43.93	\$8.60	\$17.57	\$0.00	\$70.10
	06/01/2023	\$44.93	\$8.60	\$17.57	\$0.00	\$71.10
	12/01/2023	\$46.18	\$8.60	\$17.57	\$0.00	\$72.35
For apprentice rates see "Apprentice- LABORER"						
ASPHALT RAKER (HEAVY & HIGHWAY) <i>LABORERS - ZONE 1 (HEAVY & HIGHWAY)</i>	06/01/2021	\$40.92	\$8.60	\$17.57	\$0.00	\$67.09
	12/01/2021	\$41.93	\$8.60	\$17.57	\$0.00	\$68.10
For apprentice rates see "Apprentice- LABORER (Heavy and Highway)"						
ASPHALT/CONCRETE/CRUSHER PLANT-ON SITE <i>OPERATING ENGINEERS LOCAL 4</i>	06/01/2021	\$50.73	\$13.75	\$15.80	\$0.00	\$80.28
	12/01/2021	\$51.88	\$13.75	\$15.80	\$0.00	\$81.43
For apprentice rates see "Apprentice- OPERATING ENGINEERS"						
BACKHOE/FRONT-END LOADER <i>OPERATING ENGINEERS LOCAL 4</i>	06/01/2021	\$50.73	\$13.75	\$15.80	\$0.00	\$80.28
	12/01/2021	\$51.88	\$13.75	\$15.80	\$0.00	\$81.43
For apprentice rates see "Apprentice- OPERATING ENGINEERS"						
BARCO-TYPE JUMPING TAMPER <i>LABORERS - ZONE 1</i>	06/01/2021	\$40.92	\$8.60	\$17.57	\$0.00	\$67.09
	12/01/2021	\$41.93	\$8.60	\$17.57	\$0.00	\$68.10
	06/01/2022	\$42.93	\$8.60	\$17.57	\$0.00	\$69.10
	12/01/2022	\$43.93	\$8.60	\$17.57	\$0.00	\$70.10
	06/01/2023	\$44.93	\$8.60	\$17.57	\$0.00	\$71.10
	12/01/2023	\$46.18	\$8.60	\$17.57	\$0.00	\$72.35

Issue Date: 07/12/2021

Wage Request Number: 20210712-042

Page 2 of 32

Classification	Effective Date	Base Wage	Health	Pension	Supplemental Unemployment	Total Rate
For apprentice rates see "Apprentice- LABORER"						
BLOCK PAVER, RAMMER / CURB SETTER <i>LABORERS - ZONE 1</i>	06/01/2021	\$41.42	\$8.60	\$17.57	\$0.00	\$67.59
	12/01/2021	\$42.43	\$8.60	\$17.57	\$0.00	\$68.60
	06/01/2022	\$43.43	\$8.60	\$17.57	\$0.00	\$69.60
	12/01/2022	\$44.43	\$8.60	\$17.57	\$0.00	\$70.60
	06/01/2023	\$45.43	\$8.60	\$17.57	\$0.00	\$71.60
	12/01/2023	\$46.68	\$8.60	\$17.57	\$0.00	\$72.85
For apprentice rates see "Apprentice- LABORER"						
BLOCK PAVER, RAMMER / CURB SETTER (HEAVY & HIGHWAY) <i>LABORERS - ZONE 1 (HEAVY & HIGHWAY)</i>	06/01/2021	\$41.42	\$8.60	\$17.57	\$0.00	\$67.59
	12/01/2021	\$42.43	\$8.60	\$17.57	\$0.00	\$68.60
For apprentice rates see "Apprentice- LABORER (Heavy and Highway)"						
BOILER MAKER <i>BOILERMAKERS LOCAL 29</i>	01/01/2020	\$46.10	\$7.07	\$17.98	\$0.00	\$71.15

Apprentice - BOILERMAKER - Local 29

Effective Date - 01/01/2020

Step	percent	Apprentice Base Wage	Health	Pension	Supplemental Unemployment	Total Rate
1	65	\$29.97	\$7.07	\$11.69	\$0.00	\$48.73
2	65	\$29.97	\$7.07	\$11.69	\$0.00	\$48.73
3	70	\$32.27	\$7.07	\$12.59	\$0.00	\$51.93
4	75	\$34.58	\$7.07	\$13.49	\$0.00	\$55.14
5	80	\$36.88	\$7.07	\$14.38	\$0.00	\$58.33
6	85	\$39.19	\$7.07	\$15.29	\$0.00	\$61.55
7	90	\$41.49	\$7.07	\$16.18	\$0.00	\$64.74
8	95	\$43.80	\$7.07	\$17.09	\$0.00	\$67.96

Notes:

Apprentice to Journeyworker Ratio:1:4

BRICK/STONE/ARTIFICIAL MASONRY (INCL. MASONRY WATERPROOFING) <i>BRICKLAYERS LOCAL 3 (NEWTON)</i>	02/01/2021	\$55.75	\$11.39	\$22.09	\$0.00	\$89.23
	08/01/2021	\$57.15	\$11.39	\$22.25	\$0.00	\$90.79
	02/01/2022	\$57.74	\$11.39	\$22.25	\$0.00	\$91.38

Issue Date: 07/12/2021

Wage Request Number: 20210712-042

Page 3 of 32

Classification

Effective Date Base Wage Health Pension Supplemental Unemployment Total Rate

Apprentice - BRICK/PLASTER/CEMENT MASON - Local 3 Newton

Effective Date - 02/01/2021

Step	percent	Apprentice Base Wage	Health	Pension	Supplemental Unemployment	Total Rate
1	50	\$27.88	\$11.39	\$22.09	\$0.00	\$61.36
2	60	\$33.45	\$11.39	\$22.09	\$0.00	\$66.93
3	70	\$39.03	\$11.39	\$22.09	\$0.00	\$72.51
4	80	\$44.60	\$11.39	\$22.09	\$0.00	\$78.08
5	90	\$50.18	\$11.39	\$22.09	\$0.00	\$83.66

Effective Date - 08/01/2021

Step	percent	Apprentice Base Wage	Health	Pension	Supplemental Unemployment	Total Rate
1	50	\$28.58	\$11.39	\$22.25	\$0.00	\$62.22
2	60	\$34.29	\$11.39	\$22.25	\$0.00	\$67.93
3	70	\$40.01	\$11.39	\$22.25	\$0.00	\$73.65
4	80	\$45.72	\$11.39	\$22.25	\$0.00	\$79.36
5	90	\$51.44	\$11.39	\$22.25	\$0.00	\$85.08

Notes:

Apprentice to Journeyworker Ratio:1:5

BULLDOZER/GRADER/SCRAPER <i>OPERATING ENGINEERS LOCAL 4</i>	06/01/2021	\$50.19	\$13.75	\$15.80	\$0.00	\$79.74
For apprentice rates see "Apprentice- OPERATING ENGINEERS"	12/01/2021	\$51.33	\$13.75	\$15.80	\$0.00	\$80.88
CAISSON & UNDERPINNING BOTTOM MAN <i>LABORERS - FOUNDATION AND MARINE</i>	06/01/2021	\$41.82	\$8.60	\$17.72	\$0.00	\$68.14
For apprentice rates see "Apprentice- LABORER"	12/01/2021	\$42.83	\$8.60	\$17.72	\$0.00	\$69.15
CAISSON & UNDERPINNING LABORER <i>LABORERS - FOUNDATION AND MARINE</i>	06/01/2021	\$40.67	\$8.60	\$17.72	\$0.00	\$66.99
For apprentice rates see "Apprentice- LABORER"	12/01/2021	\$41.68	\$8.60	\$17.72	\$0.00	\$68.00
CAISSON & UNDERPINNING TOP MAN <i>LABORERS - FOUNDATION AND MARINE</i>	06/01/2021	\$40.67	\$8.60	\$17.72	\$0.00	\$66.99
For apprentice rates see "Apprentice- LABORER"	12/01/2021	\$41.68	\$8.60	\$17.72	\$0.00	\$68.00
CARBIDE CORE DRILL OPERATOR <i>LABORERS - ZONE 1</i>	06/01/2021	\$40.92	\$8.60	\$17.57	\$0.00	\$67.09
	12/01/2021	\$41.93	\$8.60	\$17.57	\$0.00	\$68.10
	06/01/2022	\$42.93	\$8.60	\$17.57	\$0.00	\$69.10
	12/01/2022	\$43.93	\$8.60	\$17.57	\$0.00	\$70.10
	06/01/2023	\$44.93	\$8.60	\$17.57	\$0.00	\$71.10
For apprentice rates see "Apprentice- LABORER"	12/01/2023	\$46.18	\$8.60	\$17.57	\$0.00	\$72.35
CARPENTER <i>CARPENTERS -ZONE 2 (Eastern Massachusetts)</i>	03/01/2021	\$43.54	\$9.40	\$18.95	\$0.00	\$71.89
	09/01/2021	\$44.19	\$9.40	\$18.95	\$0.00	\$72.54
	03/01/2022	\$44.79	\$9.40	\$18.95	\$0.00	\$73.14
	09/01/2022	\$45.44	\$9.40	\$18.95	\$0.00	\$73.79
	03/01/2023	\$46.04	\$9.40	\$18.95	\$0.00	\$74.39

Issue Date: 07/12/2021

Wage Request Number: 20210712-042

Page 4 of 32

Classification

Effective Date Base Wage Health Pension Supplemental Unemployment Total Rate

Apprentice - CARPENTER - Zone 2 Eastern MA

Effective Date - 03/01/2021

Step	percent	Apprentice Base Wage	Health	Pension	Supplemental Unemployment	Total Rate
1	50	\$21.77	\$9.40	\$1.73	\$0.00	\$32.90
2	60	\$26.12	\$9.40	\$1.73	\$0.00	\$37.25
3	70	\$30.48	\$9.40	\$13.76	\$0.00	\$53.64
4	75	\$32.66	\$9.40	\$13.76	\$0.00	\$55.82
5	80	\$34.83	\$9.40	\$15.49	\$0.00	\$59.72
6	80	\$34.83	\$9.40	\$15.49	\$0.00	\$59.72
7	90	\$39.19	\$9.40	\$17.22	\$0.00	\$65.81
8	90	\$39.19	\$9.40	\$17.22	\$0.00	\$65.81

Effective Date - 09/01/2021

Step	percent	Apprentice Base Wage	Health	Pension	Supplemental Unemployment	Total Rate
1	50	\$22.10	\$9.40	\$1.73	\$0.00	\$33.23
2	60	\$26.51	\$9.40	\$1.73	\$0.00	\$37.64
3	70	\$30.93	\$9.40	\$13.76	\$0.00	\$54.09
4	75	\$33.14	\$9.40	\$13.76	\$0.00	\$56.30
5	80	\$35.35	\$9.40	\$15.49	\$0.00	\$60.24
6	80	\$35.35	\$9.40	\$15.49	\$0.00	\$60.24
7	90	\$39.77	\$9.40	\$17.22	\$0.00	\$66.39
8	90	\$39.77	\$9.40	\$17.22	\$0.00	\$66.39

Notes:
 % Indentured After 10/1/17; 45/45/55/55/70/70/80/80
 Step 1&2 \$30.72/ 3&4 \$36.75/ 5&6 \$55.37/ 7&8 \$61.45

Apprentice to Journeyworker Ratio:1:5

CARPENTER WOOD FRAME	04/01/2021	\$27.87	\$7.21	\$5.80	\$0.00	\$40.88
CARPENTERS -ZONE 2 (Wood Frame)	04/01/2022	\$28.62	\$7.21	\$5.80	\$0.00	\$41.63
	04/01/2023	\$28.97	\$7.21	\$5.80	\$0.00	\$41.98

All Aspects of New Wood Frame Work

Issue Date: 07/12/2021

Wage Request Number: 20210712-042

Page 5 of 32

Classification

Effective Date Base Wage Health Pension Supplemental Unemployment Total Rate

Apprentice - CARPENTER (Wood Frame) - Zone 2

Effective Date - 04/01/2021

Step	percent	Apprentice Base Wage	Health	Pension	Supplemental Unemployment	Total Rate
1	60	\$16.72	\$7.21	\$0.00	\$0.00	\$23.93
2	60	\$16.72	\$7.21	\$0.00	\$0.00	\$23.93
3	65	\$18.12	\$7.21	\$2.00	\$0.00	\$27.33
4	70	\$19.51	\$7.21	\$2.00	\$0.00	\$28.72
5	75	\$20.90	\$7.21	\$5.80	\$0.00	\$33.91
6	80	\$22.30	\$7.21	\$5.80	\$0.00	\$35.31
7	85	\$23.69	\$7.21	\$5.80	\$0.00	\$36.70
8	90	\$25.08	\$7.21	\$5.80	\$0.00	\$38.09

Effective Date - 04/01/2022

Step	percent	Apprentice Base Wage	Health	Pension	Supplemental Unemployment	Total Rate
1	60	\$17.17	\$7.21	\$0.00	\$0.00	\$24.38
2	60	\$17.17	\$7.21	\$0.00	\$0.00	\$24.38
3	65	\$18.60	\$7.21	\$2.00	\$0.00	\$27.81
4	70	\$20.03	\$7.21	\$2.00	\$0.00	\$29.24
5	75	\$21.47	\$7.21	\$5.80	\$0.00	\$34.48
6	80	\$22.90	\$7.21	\$5.80	\$0.00	\$35.91
7	85	\$24.33	\$7.21	\$5.80	\$0.00	\$37.34
8	90	\$25.76	\$7.21	\$5.80	\$0.00	\$38.77

Notes:
 % Indentured After 10/1/17; 45/45/55/55/70/70/80/80
 Step 1&2 \$19.75/ 3&4 \$24.54/ 5&6 \$32.52/ 7&8 \$35.31

Apprentice to Journeyworker Ratio:1:5

CEMENT MASONRY/PLASTERING BRICKLAYERS LOCAL 3 (NEWTON)	01/01/2020	\$49.07	\$12.75	\$22.41	\$0.62	\$84.85
---	------------	---------	---------	---------	--------	---------

Apprentice - CEMENT MASONRY/PLASTERING - Eastern Mass (Newton)

Effective Date - 01/01/2020

Step	percent	Apprentice Base Wage	Health	Pension	Supplemental Unemployment	Total Rate
1	50	\$24.54	\$12.75	\$15.41	\$0.00	\$52.70
2	60	\$29.44	\$12.75	\$17.41	\$0.62	\$60.22
3	65	\$31.90	\$12.75	\$18.41	\$0.62	\$63.68
4	70	\$34.35	\$12.75	\$19.41	\$0.62	\$67.13
5	75	\$36.80	\$12.75	\$20.41	\$0.62	\$70.58
6	80	\$39.26	\$12.75	\$21.41	\$0.62	\$74.04
7	90	\$44.16	\$12.75	\$22.41	\$0.62	\$79.94

Notes:
 Steps 3,4 are 500 hrs. All other steps are 1,000 hrs.

Apprentice to Journeyworker Ratio:1:3

Classification	Effective Date	Base Wage	Health	Pension	Supplemental Unemployment	Total Rate
CHAIN SAW OPERATOR <i>LABORERS - ZONE 1</i>	06/01/2021	\$40.92	\$8.60	\$17.57	\$0.00	\$67.09
	12/01/2021	\$41.93	\$8.60	\$17.57	\$0.00	\$68.10
	06/01/2022	\$42.93	\$8.60	\$17.57	\$0.00	\$69.10
	12/01/2022	\$43.93	\$8.60	\$17.57	\$0.00	\$70.10
	06/01/2023	\$44.93	\$8.60	\$17.57	\$0.00	\$71.10
	12/01/2023	\$46.18	\$8.60	\$17.57	\$0.00	\$72.35
For apprentice rates see "Apprentice- LABORER"						
CLAM SHELLS/SLURRY BUCKETS/HEADING MACHINES <i>OPERATING ENGINEERS LOCAL 4</i>	06/01/2021	\$51.73	\$13.75	\$15.80	\$0.00	\$81.28
	12/01/2021	\$52.88	\$13.75	\$15.80	\$0.00	\$82.43
For apprentice rates see "Apprentice- OPERATING ENGINEERS"						
COMPRESSOR OPERATOR <i>OPERATING ENGINEERS LOCAL 4</i>	06/01/2021	\$33.40	\$13.75	\$15.80	\$0.00	\$62.95
	12/01/2021	\$34.19	\$13.75	\$15.80	\$0.00	\$63.74
For apprentice rates see "Apprentice- OPERATING ENGINEERS"						
DELEADER (BRIDGE) <i>PAINTERS LOCAL 35 - ZONE 2</i>	01/01/2021	\$52.06	\$8.25	\$22.75	\$0.00	\$83.06

Apprentice - PAINTER Local 35 - BRIDGES/TANKS

Effective Date - 01/01/2021

Step	percent	Apprentice Base Wage	Health	Pension	Supplemental Unemployment	Total Rate
1	50	\$26.03	\$8.25	\$0.00	\$0.00	\$34.28
2	55	\$28.63	\$8.25	\$6.16	\$0.00	\$43.04
3	60	\$31.24	\$8.25	\$6.72	\$0.00	\$46.21
4	65	\$33.84	\$8.25	\$7.28	\$0.00	\$49.37
5	70	\$36.44	\$8.25	\$19.39	\$0.00	\$64.08
6	75	\$39.05	\$8.25	\$19.95	\$0.00	\$67.25
7	80	\$41.65	\$8.25	\$20.51	\$0.00	\$70.41
8	90	\$46.85	\$8.25	\$21.63	\$0.00	\$76.73

Notes:

Steps are 750 hrs.

Apprentice to Journeyworker Ratio:1:1

DEMO: ADZEMAN <i>LABORERS - ZONE 1</i>	06/01/2021	\$40.82	\$8.60	\$17.57	\$0.00	\$66.99
	12/01/2021	\$41.83	\$8.60	\$17.57	\$0.00	\$68.00
	06/01/2022	\$42.83	\$8.60	\$17.57	\$0.00	\$69.00
	12/01/2022	\$43.83	\$8.60	\$17.57	\$0.00	\$70.00
	06/01/2023	\$44.83	\$8.60	\$17.57	\$0.00	\$71.00
	12/01/2023	\$46.08	\$8.60	\$17.57	\$0.00	\$72.25
For apprentice rates see "Apprentice- LABORER"						
DEMO: BACKHOE/LOADER/HAMMER OPERATOR <i>LABORERS - ZONE 1</i>	06/01/2021	\$41.82	\$8.60	\$17.57	\$0.00	\$67.99
	12/01/2021	\$42.83	\$8.60	\$17.57	\$0.00	\$69.00
	06/01/2022	\$43.83	\$8.60	\$17.57	\$0.00	\$70.00
	12/01/2022	\$44.83	\$8.60	\$17.57	\$0.00	\$71.00
	06/01/2023	\$45.83	\$8.60	\$17.57	\$0.00	\$72.00
	12/01/2023	\$47.08	\$8.60	\$17.57	\$0.00	\$73.25
For apprentice rates see "Apprentice- LABORER"						

Issue Date: 07/12/2021

Wage Request Number: 20210712-042

Page 7 of 32

Classification	Effective Date	Base Wage	Health	Pension	Supplemental Unemployment	Total Rate
DEMO: BURNERS <i>LABORERS - ZONE 1</i>	06/01/2021	\$41.57	\$8.60	\$17.57	\$0.00	\$67.74
	12/01/2021	\$42.58	\$8.60	\$17.57	\$0.00	\$68.75
	06/01/2022	\$43.58	\$8.60	\$17.57	\$0.00	\$69.75
	12/01/2022	\$44.58	\$8.60	\$17.57	\$0.00	\$70.75
	06/01/2023	\$45.58	\$8.60	\$17.57	\$0.00	\$71.75
	12/01/2023	\$46.83	\$8.60	\$17.57	\$0.00	\$73.00
For apprentice rates see "Apprentice- LABORER"						
DEMO: CONCRETE CUTTER/SAWYER <i>LABORERS - ZONE 1</i>	06/01/2021	\$41.82	\$8.60	\$17.57	\$0.00	\$67.99
	12/01/2021	\$42.83	\$8.60	\$17.57	\$0.00	\$69.00
	06/01/2022	\$43.83	\$8.60	\$17.57	\$0.00	\$70.00
	12/01/2022	\$44.83	\$8.60	\$17.57	\$0.00	\$71.00
	06/01/2023	\$45.83	\$8.60	\$17.57	\$0.00	\$72.00
	12/01/2023	\$47.08	\$8.60	\$17.57	\$0.00	\$73.25
For apprentice rates see "Apprentice- LABORER"						
DEMO: JACKHAMMER OPERATOR <i>LABORERS - ZONE 1</i>	06/01/2021	\$41.57	\$8.60	\$17.57	\$0.00	\$67.74
	12/01/2021	\$42.58	\$8.60	\$17.57	\$0.00	\$68.75
	06/01/2022	\$43.58	\$8.60	\$17.57	\$0.00	\$69.75
	12/01/2022	\$44.58	\$8.60	\$17.57	\$0.00	\$70.75
	06/01/2023	\$45.58	\$8.60	\$17.57	\$0.00	\$71.75
	12/01/2023	\$46.83	\$8.60	\$17.57	\$0.00	\$73.00
For apprentice rates see "Apprentice- LABORER"						
DEMO: WRECKING LABORER <i>LABORERS - ZONE 1</i>	06/01/2021	\$40.82	\$8.60	\$17.57	\$0.00	\$66.99
	12/01/2021	\$41.83	\$8.60	\$17.57	\$0.00	\$68.00
	06/01/2022	\$42.83	\$8.60	\$17.57	\$0.00	\$69.00
	12/01/2022	\$43.83	\$8.60	\$17.57	\$0.00	\$70.00
	06/01/2023	\$44.83	\$8.60	\$17.57	\$0.00	\$71.00
	12/01/2023	\$46.08	\$8.60	\$17.57	\$0.00	\$72.25
For apprentice rates see "Apprentice- LABORER"						
DIRECTIONAL DRILL MACHINE OPERATOR <i>OPERATING ENGINEERS LOCAL 4</i>	06/01/2021	\$50.19	\$13.75	\$15.80	\$0.00	\$79.74
	12/01/2021	\$51.33	\$13.75	\$15.80	\$0.00	\$80.88
For apprentice rates see "Apprentice- OPERATING ENGINEERS"						
DIVER <i>PILE DRIVER LOCAL 56 (ZONE 1)</i>	08/01/2020	\$68.70	\$9.40	\$23.12	\$0.00	\$101.22
For apprentice rates see "Apprentice- PILE DRIVER"						
DIVER TENDER <i>PILE DRIVER LOCAL 56 (ZONE 1)</i>	08/01/2020	\$49.07	\$9.40	\$23.12	\$0.00	\$81.59
For apprentice rates see "Apprentice- PILE DRIVER"						
DIVER TENDER (EFFLUENT) <i>PILE DRIVER LOCAL 56 (ZONE 1)</i>	08/01/2020	\$73.60	\$9.40	\$23.12	\$0.00	\$106.12
For apprentice rates see "Apprentice- PILE DRIVER"						
DIVER/SLURRY (EFFLUENT) <i>PILE DRIVER LOCAL 56 (ZONE 1)</i>	08/01/2020	\$103.05	\$9.40	\$23.12	\$0.00	\$135.57
For apprentice rates see "Apprentice- PILE DRIVER"						
DRAWBRIDGE OPERATOR (Construction) <i>DRAWBRIDGE - SEIU LOCAL 888</i>	07/01/2020	\$26.77	\$6.67	\$3.93	\$0.16	\$37.53

Classification	Effective Date	Base Wage	Health	Pension	Supplemental Unemployment	Total Rate
ELECTRICIAN ELECTRICIANS LOCAL 103	03/01/2021	\$55.41	\$13.00	\$20.01	\$0.00	\$88.42
	09/01/2021	\$56.84	\$13.00	\$20.06	\$0.00	\$89.90
	03/01/2022	\$58.04	\$13.00	\$20.09	\$0.00	\$91.13
	09/01/2022	\$59.48	\$13.00	\$20.13	\$0.00	\$92.61
	03/01/2023	\$60.67	\$13.00	\$20.17	\$0.00	\$93.84

Apprentice - ELECTRICIAN - Local 103

Effective Date - 03/01/2021

Step	percent	Apprentice Base Wage	Health	Pension	Supplemental Unemployment	Total Rate
1	40	\$22.16	\$13.00	\$0.66	\$0.00	\$35.82
2	40	\$22.16	\$13.00	\$0.66	\$0.00	\$35.82
3	45	\$24.93	\$13.00	\$15.13	\$0.00	\$53.06
4	45	\$24.93	\$13.00	\$15.13	\$0.00	\$53.06
5	50	\$27.71	\$13.00	\$15.57	\$0.00	\$56.28
6	55	\$30.48	\$13.00	\$16.01	\$0.00	\$59.49
7	60	\$33.25	\$13.00	\$16.46	\$0.00	\$62.71
8	65	\$36.02	\$13.00	\$16.90	\$0.00	\$65.92
9	70	\$38.79	\$13.00	\$17.34	\$0.00	\$69.13
10	75	\$41.56	\$13.00	\$17.80	\$0.00	\$72.36

Effective Date - 09/01/2021

Step	percent	Apprentice Base Wage	Health	Pension	Supplemental Unemployment	Total Rate
1	40	\$22.74	\$13.00	\$0.68	\$0.00	\$36.42
2	40	\$22.74	\$13.00	\$0.68	\$0.00	\$36.42
3	45	\$25.58	\$13.00	\$15.15	\$0.00	\$53.73
4	45	\$25.58	\$13.00	\$15.15	\$0.00	\$53.73
5	50	\$28.42	\$13.00	\$15.59	\$0.00	\$57.01
6	55	\$31.26	\$13.00	\$16.04	\$0.00	\$60.30
7	60	\$34.10	\$13.00	\$16.48	\$0.00	\$63.58
8	65	\$36.95	\$13.00	\$16.93	\$0.00	\$66.88
9	70	\$39.79	\$13.00	\$17.37	\$0.00	\$70.16
10	75	\$42.63	\$13.00	\$17.83	\$0.00	\$73.46

Notes:
App Prior 1/1/03; 30/35/40/45/50/55/65/70/75/80

Apprentice to Journeyworker Ratio:2:3***

ELEVATOR CONSTRUCTOR ELEVATOR CONSTRUCTORS LOCAL 4	01/01/2021	\$63.47	\$15.88	\$19.31	\$0.00	\$98.66
	01/01/2022	\$65.62	\$16.03	\$20.21	\$0.00	\$101.86

Classification

Effective Date Base Wage Health Pension Supplemental Unemployment Total Rate

Apprentice - ELEVATOR CONSTRUCTOR - Local 4

Effective Date - 01/01/2021

Step	percent	Apprentice Base Wage	Health	Pension	Supplemental Unemployment	Total Rate
1	50	\$31.74	\$15.88	\$0.00	\$0.00	\$47.62
2	55	\$34.91	\$15.88	\$19.31	\$0.00	\$70.10
3	65	\$41.26	\$15.88	\$19.31	\$0.00	\$76.45
4	70	\$44.43	\$15.88	\$19.31	\$0.00	\$79.62
5	80	\$50.78	\$15.88	\$19.31	\$0.00	\$85.97

Effective Date - 01/01/2022

Step	percent	Apprentice Base Wage	Health	Pension	Supplemental Unemployment	Total Rate
1	50	\$32.81	\$16.03	\$0.00	\$0.00	\$48.84
2	55	\$36.09	\$16.03	\$20.21	\$0.00	\$72.33
3	65	\$42.65	\$16.03	\$20.21	\$0.00	\$78.89
4	70	\$45.93	\$16.03	\$20.21	\$0.00	\$82.17
5	80	\$52.50	\$16.03	\$20.21	\$0.00	\$88.74

Notes:
Steps 1-2 are 6 mos.; Steps 3-5 are 1 year

Apprentice to Journeyworker Ratio:1:1

ELEVATOR CONSTRUCTOR HELPER <i>ELEVATOR CONSTRUCTORS LOCAL 4</i>	01/01/2021	\$44.43	\$15.88	\$19.31	\$0.00	\$79.62
	01/01/2022	\$45.93	\$16.03	\$20.21	\$0.00	\$82.17
For apprentice rates see "Apprentice - ELEVATOR CONSTRUCTOR"						
FENCE & GUARD RAIL ERECTOR (HEAVY & HIGHWAY) <i>LABORERS - ZONE 1 (HEAVY & HIGHWAY)</i>	06/01/2021	\$40.92	\$8.60	\$17.57	\$0.00	\$67.09
	12/01/2021	\$41.93	\$8.60	\$17.57	\$0.00	\$68.10
For apprentice rates see "Apprentice- LABORER (Heavy and Highway)"						
FIELD ENG. INST. PERSON-BLDG, SITE, HVY/HWY <i>OPERATING ENGINEERS LOCAL 4</i>	05/01/2021	\$45.88	\$13.50	\$15.70	\$0.00	\$75.08
	11/01/2021	\$46.88	\$13.50	\$15.70	\$0.00	\$76.08
	05/01/2022	\$48.03	\$13.50	\$15.70	\$0.00	\$77.23
For apprentice rates see "Apprentice- OPERATING ENGINEERS"						
FIELD ENG. PARTY CHIEF-BLDG, SITE, HVY/HWY <i>OPERATING ENGINEERS LOCAL 4</i>	05/01/2021	\$47.40	\$13.50	\$15.70	\$0.00	\$76.60
	11/01/2021	\$48.41	\$13.50	\$15.70	\$0.00	\$77.61
	05/01/2022	\$49.57	\$13.50	\$15.70	\$0.00	\$78.77
For apprentice rates see "Apprentice- OPERATING ENGINEERS"						
FIELD ENG. ROD PERSON-BLDG, SITE, HVY/HWY <i>OPERATING ENGINEERS LOCAL 4</i>	05/01/2021	\$22.91	\$13.50	\$15.70	\$0.00	\$52.11
	11/01/2021	\$23.51	\$13.50	\$15.70	\$0.00	\$52.71
	05/01/2022	\$24.18	\$13.50	\$15.70	\$0.00	\$53.38
For apprentice rates see "Apprentice- OPERATING ENGINEERS"						
FIRE ALARM INSTALLER <i>ELECTRICIANS LOCAL 103</i>	03/01/2021	\$55.41	\$13.00	\$20.01	\$0.00	\$88.42
	09/01/2021	\$56.84	\$13.00	\$20.06	\$0.00	\$89.90
	03/01/2022	\$58.04	\$13.00	\$20.09	\$0.00	\$91.13
	09/01/2022	\$59.48	\$13.00	\$20.13	\$0.00	\$92.61
	03/01/2023	\$60.67	\$13.00	\$20.17	\$0.00	\$93.84
For apprentice rates see "Apprentice- ELECTRICIAN"						

Issue Date: 07/12/2021

Wage Request Number: 20210712-042

Page 10 of 32

Classification	Effective Date	Base Wage	Health	Pension	Supplemental Unemployment	Total Rate
FIRE ALARM REPAIR / MAINTENANCE / COMMISSIONING <i>ELECTRICIANS</i> <i>LOCAL 103</i>	03/01/2021	\$42.11	\$13.00	\$17.88	\$0.00	\$72.99
	09/01/2021	\$43.77	\$13.00	\$18.00	\$0.00	\$74.77
	03/01/2022	\$45.27	\$13.00	\$18.12	\$0.00	\$76.39
	09/01/2022	\$46.99	\$13.00	\$18.24	\$0.00	\$78.23
	03/01/2023	\$48.54	\$13.00	\$18.37	\$0.00	\$79.91
For apprentice rates see "Apprentice- TELECOMMUNICATIONS TECHNICIAN"						
FIREMAN (ASST. ENGINEER) <i>OPERATING ENGINEERS LOCAL 4</i>	06/01/2021	\$41.31	\$13.75	\$15.80	\$0.00	\$70.86
	12/01/2021	\$42.26	\$13.75	\$15.80	\$0.00	\$71.81
For apprentice rates see "Apprentice- OPERATING ENGINEERS"						
FLAGGER & SIGNALER (HEAVY & HIGHWAY) <i>LABORERS - ZONE 1 (HEAVY & HIGHWAY)</i>	06/01/2021	\$24.50	\$8.60	\$17.57	\$0.00	\$50.67
	12/01/2021	\$24.50	\$8.60	\$17.57	\$0.00	\$50.67
For apprentice rates see "Apprentice- LABORER (Heavy and Highway)"						
FLOORCOVERER <i>FLOORCOVERERS LOCAL 2168 ZONE 1</i>	03/01/2021	\$48.59	\$9.40	\$19.25	\$0.00	\$77.24
	09/01/2021	\$49.39	\$9.40	\$19.25	\$0.00	\$78.04
	03/01/2022	\$50.19	\$9.40	\$19.25	\$0.00	\$78.84

Apprentice - FLOORCOVERER - Local 2168 Zone 1

Effective Date - 03/01/2021

Step	percent	Apprentice Base Wage	Health	Pension	Supplemental Unemployment	Total Rate
1	50	\$24.30	\$9.40	\$1.79	\$0.00	\$35.49
2	55	\$26.72	\$9.40	\$1.79	\$0.00	\$37.91
3	60	\$29.15	\$9.40	\$13.88	\$0.00	\$52.43
4	65	\$31.58	\$9.40	\$13.88	\$0.00	\$54.86
5	70	\$34.01	\$9.40	\$15.67	\$0.00	\$59.08
6	75	\$36.44	\$9.40	\$15.67	\$0.00	\$61.51
7	80	\$38.87	\$9.40	\$17.46	\$0.00	\$65.73
8	85	\$41.30	\$9.40	\$17.46	\$0.00	\$68.16

Effective Date - 09/01/2021

Step	percent	Apprentice Base Wage	Health	Pension	Supplemental Unemployment	Total Rate
1	50	\$24.70	\$9.40	\$1.79	\$0.00	\$35.89
2	55	\$27.16	\$9.40	\$1.79	\$0.00	\$38.35
3	60	\$29.63	\$9.40	\$13.88	\$0.00	\$52.91
4	65	\$32.10	\$9.40	\$13.88	\$0.00	\$55.38
5	70	\$34.57	\$9.40	\$15.67	\$0.00	\$59.64
6	75	\$37.04	\$9.40	\$15.67	\$0.00	\$62.11
7	80	\$39.51	\$9.40	\$17.46	\$0.00	\$66.37
8	85	\$41.98	\$9.40	\$17.46	\$0.00	\$68.84

Notes: Steps are 750 hrs.
% After 09/1/17; 45/45/55/55/70/70/80/80 (1500hr Steps)
Step 1&2 \$33.03/ 3&4 \$39.64/ 5&6 \$59.08/ 7&8 \$65.73

Apprentice to Journeyworker Ratio:1:1

FORK LIFT/CHERRY PICKER <i>OPERATING ENGINEERS LOCAL 4</i>	06/01/2021	\$50.73	\$13.75	\$15.80	\$0.00	\$80.28
	12/01/2021	\$51.88	\$13.75	\$15.80	\$0.00	\$81.43
For apprentice rates see "Apprentice- OPERATING ENGINEERS"						

Classification	Effective Date	Base Wage	Health	Pension	Supplemental Unemployment	Total Rate
GENERATOR/LIGHTING PLANT/HEATERS <i>OPERATING ENGINEERS LOCAL 4</i>	06/01/2021	\$33.40	\$13.75	\$15.80	\$0.00	\$62.95
	12/01/2021	\$34.19	\$13.75	\$15.80	\$0.00	\$63.74
For apprentice rates see "Apprentice- OPERATING ENGINEERS"						
GLAZIER (GLASS PLANK/AIR BARRIER/INTERIOR SYSTEMS) <i>GLAZIERS LOCAL 35 (ZONE 2)</i>	01/01/2021	\$41.56	\$8.25	\$22.75	\$0.00	\$72.56

Apprentice - GLAZIER - Local 35 Zone 2

Effective Date - 01/01/2021

Step	percent	Apprentice Base Wage	Health	Pension	Supplemental Unemployment	Total Rate
1	50	\$20.78	\$8.25	\$0.00	\$0.00	\$29.03
2	55	\$22.86	\$8.25	\$6.16	\$0.00	\$37.27
3	60	\$24.94	\$8.25	\$6.72	\$0.00	\$39.91
4	65	\$27.01	\$8.25	\$7.28	\$0.00	\$42.54
5	70	\$29.09	\$8.25	\$19.39	\$0.00	\$56.73
6	75	\$31.17	\$8.25	\$19.95	\$0.00	\$59.37
7	80	\$33.25	\$8.25	\$20.51	\$0.00	\$62.01
8	90	\$37.40	\$8.25	\$21.63	\$0.00	\$67.28

Notes:

Steps are 750 hrs.

Apprentice to Journeyworker Ratio:1:1

HOISTING ENGINEER/CRANES/GRADALLS <i>OPERATING ENGINEERS LOCAL 4</i>	06/01/2021	\$50.73	\$13.75	\$15.80	\$0.00	\$80.28
	12/01/2021	\$51.88	\$13.75	\$15.80	\$0.00	\$81.43

Issue Date: 07/12/2021

Wage Request Number: 20210712-042

Page 12 of 32

Classification Effective Date Base Wage Health Pension Supplemental Unemployment Total Rate

Apprentice - OPERATING ENGINEERS - Local 4

Effective Date - 06/01/2021

Step	percent	Apprentice Base Wage	Health	Pension	Supplemental Unemployment	Total Rate
1	55	\$27.90	\$13.75	\$0.00	\$0.00	\$41.65
2	60	\$30.44	\$13.75	\$15.80	\$0.00	\$59.99
3	65	\$32.97	\$13.75	\$15.80	\$0.00	\$62.52
4	70	\$35.51	\$13.75	\$15.80	\$0.00	\$65.06
5	75	\$38.05	\$13.75	\$15.80	\$0.00	\$67.60
6	80	\$40.58	\$13.75	\$15.80	\$0.00	\$70.13
7	85	\$43.12	\$13.75	\$15.80	\$0.00	\$72.67
8	90	\$45.66	\$13.75	\$15.80	\$0.00	\$75.21

Effective Date - 12/01/2021

Step	percent	Apprentice Base Wage	Health	Pension	Supplemental Unemployment	Total Rate
1	55	\$28.53	\$13.75	\$0.00	\$0.00	\$42.28
2	60	\$31.13	\$13.75	\$15.80	\$0.00	\$60.68
3	65	\$33.72	\$13.75	\$15.80	\$0.00	\$63.27
4	70	\$36.32	\$13.75	\$15.80	\$0.00	\$65.87
5	75	\$38.91	\$13.75	\$15.80	\$0.00	\$68.46
6	80	\$41.50	\$13.75	\$15.80	\$0.00	\$71.05
7	85	\$44.10	\$13.75	\$15.80	\$0.00	\$73.65
8	90	\$46.69	\$13.75	\$15.80	\$0.00	\$76.24

Notes:

Apprentice to Journeyworker Ratio:1:6

HVAC (DUCTWORK) SHEETMETAL WORKERS LOCAL 17 - A	02/01/2021	\$51.67	\$13.65	\$24.57	\$2.70	\$92.59
	08/01/2021	\$53.42	\$13.65	\$24.57	\$2.75	\$94.39
	02/01/2022	\$55.17	\$13.65	\$24.57	\$2.80	\$96.19
For apprentice rates see "Apprentice- SHEET METAL WORKER"						
HVAC (ELECTRICAL CONTROLS) ELECTRICIANS LOCAL 103	03/01/2021	\$55.41	\$13.00	\$20.01	\$0.00	\$88.42
	09/01/2021	\$56.84	\$13.00	\$20.06	\$0.00	\$89.90
	03/01/2022	\$58.04	\$13.00	\$20.09	\$0.00	\$91.13
	09/01/2022	\$59.48	\$13.00	\$20.13	\$0.00	\$92.61
	03/01/2023	\$60.67	\$13.00	\$20.17	\$0.00	\$93.84
For apprentice rates see "Apprentice- ELECTRICIAN"						
HVAC (TESTING AND BALANCING - AIR) SHEETMETAL WORKERS LOCAL 17 - A	02/01/2021	\$51.67	\$13.65	\$24.57	\$2.70	\$92.59
	08/01/2021	\$53.42	\$13.65	\$24.57	\$2.75	\$94.39
	02/01/2022	\$55.17	\$13.65	\$24.57	\$2.80	\$96.19
For apprentice rates see "Apprentice- SHEET METAL WORKER"						
HVAC (TESTING AND BALANCING -WATER) PIPEFITTERS LOCAL 537	03/01/2021	\$57.94	\$11.70	\$20.24	\$0.00	\$89.88
	For apprentice rates see "Apprentice- PIPEFITTER" or "PLUMBER/PIPEFITTER"					
HVAC MECHANIC PIPEFITTERS LOCAL 537	03/01/2021	\$57.94	\$11.70	\$20.24	\$0.00	\$89.88

Issue Date: 07/12/2021

Wage Request Number: 20210712-042

Page 13 of 32

Classification	Effective Date	Base Wage	Health	Pension	Supplemental Unemployment	Total Rate
For apprentice rates see "Apprentice- PIPEFITTER" or "PLUMBER/PIPEFITTER"						
HYDRAULIC DRILLS <i>LABORERS - ZONE 1</i>	06/01/2021	\$41.42	\$8.60	\$17.57	\$0.00	\$67.59
	12/01/2021	\$42.43	\$8.60	\$17.57	\$0.00	\$68.60
	06/01/2022	\$43.43	\$8.60	\$17.57	\$0.00	\$69.60
	12/01/2022	\$44.43	\$8.60	\$17.57	\$0.00	\$70.60
	06/01/2023	\$45.43	\$8.60	\$17.57	\$0.00	\$71.60
	12/01/2023	\$46.68	\$8.60	\$17.57	\$0.00	\$72.85
For apprentice rates see "Apprentice- LABORER"						
HYDRAULIC DRILLS (HEAVY & HIGHWAY) <i>LABORERS - ZONE 1 (HEAVY & HIGHWAY)</i>	06/01/2021	\$41.42	\$8.60	\$17.57	\$0.00	\$67.59
	12/01/2021	\$42.43	\$8.60	\$17.57	\$0.00	\$68.60
For apprentice rates see "Apprentice- LABORER (Heavy and Highway)"						
INSULATOR (PIPES & TANKS) <i>HEAT & FROST INSULATORS LOCAL 6 (BOSTON)</i>	09/01/2020	\$49.00	\$13.80	\$17.14	\$0.00	\$79.94
	09/01/2021	\$51.40	\$13.80	\$17.14	\$0.00	\$82.34
	09/01/2022	\$53.85	\$13.80	\$17.14	\$0.00	\$84.79

Apprentice - ASBESTOS INSULATOR (Pipes & Tanks) - Local 6 Boston

Effective Date - 09/01/2020

Step	percent	Apprentice Base Wage	Health	Pension	Supplemental Unemployment	Total Rate
1	50	\$24.50	\$13.80	\$12.42	\$0.00	\$50.72
2	60	\$29.40	\$13.80	\$13.36	\$0.00	\$56.56
3	70	\$34.30	\$13.80	\$14.31	\$0.00	\$62.41
4	80	\$39.20	\$13.80	\$15.25	\$0.00	\$68.25

Effective Date - 09/01/2021

Step	percent	Apprentice Base Wage	Health	Pension	Supplemental Unemployment	Total Rate
1	50	\$25.70	\$13.80	\$12.42	\$0.00	\$51.92
2	60	\$30.84	\$13.80	\$13.36	\$0.00	\$58.00
3	70	\$35.98	\$13.80	\$14.31	\$0.00	\$64.09
4	80	\$41.12	\$13.80	\$15.25	\$0.00	\$70.17

Notes:

Steps are 1 year

Apprentice to Journeyworker Ratio:1:4

IRONWORKER/WELDER <i>IRONWORKERS LOCAL 7 (BOSTON AREA)</i>	09/16/2020	\$48.66	\$8.10	\$25.10	\$0.00	\$81.86
---	------------	---------	--------	---------	--------	---------

Issue Date: 07/12/2021

Wage Request Number: 20210712-042

Page 14 of 32

Classification

Effective Date Base Wage Health Pension Supplemental Unemployment Total Rate

Apprentice - LABORER - Zone 1

Effective Date - 06/01/2021

Step	percent	Apprentice Base Wage	Health	Pension	Supplemental Unemployment	Total Rate
1	60	\$24.40	\$8.60	\$17.57	\$0.00	\$50.57
2	70	\$28.47	\$8.60	\$17.57	\$0.00	\$54.64
3	80	\$32.54	\$8.60	\$17.57	\$0.00	\$58.71
4	90	\$36.60	\$8.60	\$17.57	\$0.00	\$62.77

Effective Date - 12/01/2021

Step	percent	Apprentice Base Wage	Health	Pension	Supplemental Unemployment	Total Rate
1	60	\$25.01	\$8.60	\$17.57	\$0.00	\$51.18
2	70	\$29.18	\$8.60	\$17.57	\$0.00	\$55.35
3	80	\$33.34	\$8.60	\$17.57	\$0.00	\$59.51
4	90	\$37.51	\$8.60	\$17.57	\$0.00	\$63.68

Notes:

Apprentice to Journeyworker Ratio:1:5

LABORER (HEAVY & HIGHWAY)	06/01/2021	\$40.67	\$8.60	\$17.57	\$0.00	\$66.84
LABORERS - ZONE 1 (HEAVY & HIGHWAY)	12/01/2021	\$41.68	\$8.60	\$17.57	\$0.00	\$67.85

Apprentice - LABORER (Heavy & Highway) - Zone 1

Effective Date - 06/01/2021

Step	percent	Apprentice Base Wage	Health	Pension	Supplemental Unemployment	Total Rate
1	60	\$24.40	\$8.60	\$17.57	\$0.00	\$50.57
2	70	\$28.47	\$8.60	\$17.57	\$0.00	\$54.64
3	80	\$32.54	\$8.60	\$17.57	\$0.00	\$58.71
4	90	\$36.60	\$8.60	\$17.57	\$0.00	\$62.77

Effective Date - 12/01/2021

Step	percent	Apprentice Base Wage	Health	Pension	Supplemental Unemployment	Total Rate
1	60	\$25.01	\$8.60	\$17.57	\$0.00	\$51.18
2	70	\$29.18	\$8.60	\$17.57	\$0.00	\$55.35
3	80	\$33.34	\$8.60	\$17.57	\$0.00	\$59.51
4	90	\$37.51	\$8.60	\$17.57	\$0.00	\$63.68

Notes:

Apprentice to Journeyworker Ratio:1:5

Classification	Effective Date	Base Wage	Health	Pension	Supplemental Unemployment	Total Rate
LABORER: CARPENTER TENDER <i>LABORERS - ZONE 1</i>	06/01/2021	\$40.67	\$8.60	\$17.57	\$0.00	\$66.84
	12/01/2021	\$41.68	\$8.60	\$17.57	\$0.00	\$67.85
	06/01/2022	\$42.68	\$8.60	\$17.57	\$0.00	\$68.85
	12/01/2022	\$43.68	\$8.60	\$17.57	\$0.00	\$69.85
	06/01/2023	\$44.68	\$8.60	\$17.57	\$0.00	\$70.85
	12/01/2023	\$45.93	\$8.60	\$17.57	\$0.00	\$72.10
For apprentice rates see "Apprentice- LABORER"						
LABORER: CEMENT FINISHER TENDER <i>LABORERS - ZONE 1</i>	06/01/2021	\$40.67	\$8.60	\$17.57	\$0.00	\$66.84
	12/01/2021	\$41.68	\$8.60	\$17.57	\$0.00	\$67.85
	06/01/2022	\$42.68	\$8.60	\$17.57	\$0.00	\$68.85
	12/01/2022	\$43.68	\$8.60	\$17.57	\$0.00	\$69.85
	06/01/2023	\$44.68	\$8.60	\$17.57	\$0.00	\$70.85
	12/01/2023	\$45.93	\$8.60	\$17.57	\$0.00	\$72.10
For apprentice rates see "Apprentice- LABORER"						
LABORER: HAZARDOUS WASTE/ASBESTOS REMOVER <i>LABORERS - ZONE 1</i>	06/01/2021	\$40.82	\$8.60	\$17.57	\$0.00	\$66.99
	12/01/2021	\$41.83	\$8.60	\$17.57	\$0.00	\$68.00
	06/01/2022	\$42.83	\$8.60	\$17.57	\$0.00	\$69.00
	12/01/2022	\$43.83	\$8.60	\$17.57	\$0.00	\$70.00
	06/01/2023	\$44.83	\$8.60	\$17.57	\$0.00	\$71.00
	12/01/2023	\$46.08	\$8.60	\$17.57	\$0.00	\$72.25
For apprentice rates see "Apprentice- LABORER"						
LABORER: MASON TENDER <i>LABORERS - ZONE 1</i>	06/01/2021	\$40.92	\$8.60	\$17.57	\$0.00	\$67.09
	12/01/2021	\$41.93	\$8.60	\$17.57	\$0.00	\$68.10
	06/01/2022	\$42.93	\$8.60	\$17.57	\$0.00	\$69.10
	12/01/2022	\$43.93	\$8.60	\$17.57	\$0.00	\$70.10
	06/01/2023	\$44.93	\$8.60	\$17.57	\$0.00	\$71.10
	06/01/2024	\$46.18	\$8.60	\$17.57	\$0.00	\$72.35
For apprentice rates see "Apprentice- LABORER"						
LABORER: MASON TENDER (HEAVY & HIGHWAY) <i>LABORERS - ZONE 1 (HEAVY & HIGHWAY)</i>	06/01/2021	\$40.92	\$8.60	\$17.57	\$0.00	\$67.09
	12/01/2021	\$41.93	\$8.60	\$17.57	\$0.00	\$68.10
For apprentice rates see "Apprentice- LABORER (Heavy and Highway)"						
LABORER: MULTI-TRADE TENDER <i>LABORERS - ZONE 1</i>	06/01/2021	\$40.67	\$8.60	\$17.57	\$0.00	\$66.84
	12/01/2021	\$41.68	\$8.60	\$17.57	\$0.00	\$67.85
	06/01/2022	\$42.68	\$8.60	\$17.57	\$0.00	\$68.85
	12/01/2022	\$43.68	\$8.60	\$17.57	\$0.00	\$69.85
	06/01/2023	\$44.68	\$8.60	\$17.57	\$0.00	\$70.85
	12/01/2023	\$45.93	\$8.60	\$17.57	\$0.00	\$72.10
For apprentice rates see "Apprentice- LABORER"						
LABORER: TREE REMOVER <i>LABORERS - ZONE 1</i>	06/01/2021	\$40.67	\$8.60	\$17.57	\$0.00	\$66.84
	12/01/2021	\$41.68	\$8.60	\$17.57	\$0.00	\$67.85
	06/01/2022	\$42.68	\$8.60	\$17.57	\$0.00	\$68.85
	12/01/2022	\$43.68	\$8.60	\$17.57	\$0.00	\$69.85
	06/01/2023	\$44.68	\$8.60	\$17.57	\$0.00	\$70.85
	12/01/2023	\$45.93	\$8.60	\$17.57	\$0.00	\$72.10
This classification applies to the removal of standing trees, and the trimming and removal of branches and limbs when related to public works construction or site clearance incidental to construction . For apprentice rates see "Apprentice- LABORER"						

Classification	Effective Date	Base Wage	Health	Pension	Supplemental Unemployment	Total Rate
LASER BEAM OPERATOR <i>LABORERS - ZONE 1</i>	06/01/2021	\$40.92	\$8.60	\$17.57	\$0.00	\$67.09
	12/01/2021	\$41.93	\$8.60	\$17.57	\$0.00	\$68.10
	06/01/2022	\$42.93	\$8.60	\$17.57	\$0.00	\$69.10
	12/01/2022	\$43.93	\$8.60	\$17.57	\$0.00	\$70.10
	06/01/2023	\$44.93	\$8.60	\$17.57	\$0.00	\$71.10
	12/01/2023	\$46.18	\$8.60	\$17.57	\$0.00	\$72.35
For apprentice rates see "Apprentice- LABORER"						
LASER BEAM OPERATOR (HEAVY & HIGHWAY) <i>LABORERS - ZONE 1 (HEAVY & HIGHWAY)</i>	06/01/2021	\$40.92	\$8.60	\$17.57	\$0.00	\$67.09
	12/01/2021	\$41.93	\$8.60	\$17.57	\$0.00	\$68.10
For apprentice rates see "Apprentice- LABORER (Heavy and Highway)"						
MARBLE & TILE FINISHERS <i>BRICKLAYERS LOCAL 3 - MARBLE & TILE</i>	02/01/2021	\$42.57	\$11.39	\$20.14	\$0.00	\$74.10
	08/01/2021	\$43.69	\$11.39	\$20.30	\$0.00	\$75.38
	02/01/2022	\$44.16	\$11.39	\$20.30	\$0.00	\$75.85

Apprentice - MARBLE & TILE FINISHER - Local 3 Marble & Tile

Effective Date - 02/01/2021

Step	percent	Apprentice Base Wage	Health	Pension	Supplemental Unemployment	Total Rate
1	50	\$21.29	\$11.39	\$20.14	\$0.00	\$52.82
2	60	\$25.54	\$11.39	\$20.14	\$0.00	\$57.07
3	70	\$29.80	\$11.39	\$20.14	\$0.00	\$61.33
4	80	\$34.06	\$11.39	\$20.14	\$0.00	\$65.59
5	90	\$38.31	\$11.39	\$20.14	\$0.00	\$69.84

Effective Date - 08/01/2021

Step	percent	Apprentice Base Wage	Health	Pension	Supplemental Unemployment	Total Rate
1	50	\$21.85	\$11.39	\$20.30	\$0.00	\$53.54
2	60	\$26.21	\$11.39	\$20.30	\$0.00	\$57.90
3	70	\$30.58	\$11.39	\$20.30	\$0.00	\$62.27
4	80	\$34.95	\$11.39	\$20.30	\$0.00	\$66.64
5	90	\$39.32	\$11.39	\$20.30	\$0.00	\$71.01

Notes:

Apprentice to Journeyworker Ratio:1:3

MARBLE MASONS, TILELAYERS & TERRAZZO MECH <i>BRICKLAYERS LOCAL 3 - MARBLE & TILE</i>	02/01/2021	\$55.77	\$11.39	\$22.08	\$0.00	\$89.24
	08/01/2021	\$57.17	\$11.39	\$22.24	\$0.00	\$90.80
	02/01/2022	\$57.74	\$11.39	\$22.24	\$0.00	\$91.37

Issue Date: 07/12/2021

Wage Request Number: 20210712-042

Page 18 of 32

Classification

Effective Date Base Wage Health Pension Supplemental Unemployment Total Rate

Apprentice - MARBLE-TILE-TERRAZZO MECHANIC - Local 3 Marble & Tile

Effective Date - 02/01/2021

Step	percent	Apprentice Base Wage	Health	Pension	Supplemental Unemployment	Total Rate
1	50	\$27.89	\$11.39	\$22.08	\$0.00	\$61.36
2	60	\$33.46	\$11.39	\$22.08	\$0.00	\$66.93
3	70	\$39.04	\$11.39	\$22.08	\$0.00	\$72.51
4	80	\$44.62	\$11.39	\$22.08	\$0.00	\$78.09
5	90	\$50.19	\$11.39	\$22.08	\$0.00	\$83.66

Effective Date - 08/01/2021

Step	percent	Apprentice Base Wage	Health	Pension	Supplemental Unemployment	Total Rate
1	50	\$28.59	\$11.39	\$22.24	\$0.00	\$62.22
2	60	\$34.30	\$11.39	\$22.24	\$0.00	\$67.93
3	70	\$40.02	\$11.39	\$22.24	\$0.00	\$73.65
4	80	\$45.74	\$11.39	\$22.24	\$0.00	\$79.37
5	90	\$51.45	\$11.39	\$22.24	\$0.00	\$85.08

Notes:

Apprentice to Journeyworker Ratio:1:5

MECH. SWEEPER OPERATOR (ON CONST. SITES) OPERATING ENGINEERS LOCAL 4	06/01/2021	\$50.19	\$13.75	\$15.80	\$0.00	\$79.74
For apprentice rates see "Apprentice- OPERATING ENGINEERS"	12/01/2021	\$51.33	\$13.75	\$15.80	\$0.00	\$80.88
MECHANICS MAINTENANCE OPERATING ENGINEERS LOCAL 4	06/01/2021	\$50.19	\$13.75	\$15.80	\$0.00	\$79.74
For apprentice rates see "Apprentice- OPERATING ENGINEERS"	12/01/2021	\$51.33	\$13.75	\$15.80	\$0.00	\$80.88
MILLWRIGHT (Zone 1) MILLWRIGHTS LOCAL 1121 - Zone 1	03/01/2021	\$43.77	\$8.58	\$21.57	\$0.00	\$73.92
	01/03/2022	\$45.52	\$8.58	\$21.57	\$0.00	\$75.67
	01/02/2023	\$47.27	\$8.58	\$21.57	\$0.00	\$77.42

Issue Date: 07/12/2021

Wage Request Number: 20210712-042

Page 19 of 32

Classification

Effective Date Base Wage Health Pension Supplemental Unemployment Total Rate

Apprentice - MILLWRIGHT - Local 1121 Zone 1

Effective Date - 03/01/2021

Step	percent	Apprentice Base Wage	Health	Pension	Supplemental Unemployment	Total Rate
1	55	\$24.07	\$8.58	\$5.72	\$0.00	\$38.37
2	65	\$28.45	\$8.58	\$17.93	\$0.00	\$54.96
3	75	\$32.83	\$8.58	\$18.98	\$0.00	\$60.39
4	85	\$37.20	\$8.58	\$20.01	\$0.00	\$65.79

Effective Date - 01/03/2022

Step	percent	Apprentice Base Wage	Health	Pension	Supplemental Unemployment	Total Rate
1	55	\$25.04	\$8.58	\$5.72	\$0.00	\$39.34
2	65	\$29.59	\$8.58	\$17.93	\$0.00	\$56.10
3	75	\$34.14	\$8.58	\$18.98	\$0.00	\$61.70
4	85	\$38.69	\$8.58	\$20.01	\$0.00	\$67.28

Notes: Step 1&2 Appr. indentured after 1/6/2020 receive no pension, but do receive annuity. (Step 1 \$5.72, Step 2 \$6.66)
Steps are 2,000 hours

Apprentice to Journeyworker Ratio:1:5

MORTAR MIXER LABORERS - ZONE 1	06/01/2021	\$40.92	\$8.60	\$17.57	\$0.00	\$67.09
	12/01/2021	\$41.93	\$8.60	\$17.57	\$0.00	\$68.10
	06/01/2022	\$42.93	\$8.60	\$17.57	\$0.00	\$69.10
	12/01/2022	\$43.93	\$8.60	\$17.57	\$0.00	\$70.10
	06/01/2023	\$44.93	\$8.60	\$17.57	\$0.00	\$71.10
	12/01/2023	\$46.18	\$8.60	\$17.57	\$0.00	\$72.35
For apprentice rates see "Apprentice- LABORER"						
OILER (OTHER THAN TRUCK CRANES,GRADALLS) OPERATING ENGINEERS LOCAL 4	06/01/2021	\$23.40	\$13.75	\$15.80	\$0.00	\$52.95
	12/01/2021	\$23.98	\$13.75	\$15.80	\$0.00	\$53.53
For apprentice rates see "Apprentice- OPERATING ENGINEERS"						
OILER (TRUCK CRANES, GRADALLS) OPERATING ENGINEERS LOCAL 4	06/01/2021	\$28.26	\$13.75	\$15.80	\$0.00	\$57.81
	12/01/2021	\$28.94	\$13.75	\$15.80	\$0.00	\$58.49
For apprentice rates see "Apprentice- OPERATING ENGINEERS"						
OTHER POWER DRIVEN EQUIPMENT - CLASS II OPERATING ENGINEERS LOCAL 4	06/01/2021	\$50.19	\$13.75	\$15.80	\$0.00	\$79.74
	12/01/2021	\$51.33	\$13.75	\$15.80	\$0.00	\$80.88
For apprentice rates see "Apprentice- OPERATING ENGINEERS"						
PAINTER (BRIDGES/TANKS) PAINTERS LOCAL 35 - ZONE 2	01/01/2021	\$52.06	\$8.25	\$22.75	\$0.00	\$83.06

Issue Date: 07/12/2021

Wage Request Number: 20210712-042

Page 20 of 32

Classification

Effective Date Base Wage Health Pension Supplemental Unemployment Total Rate

Apprentice - PAINTER Local 35 Zone 2 - BRUSH REPAINT

Effective Date - 01/01/2021

Step	percent	Apprentice Base Wage	Health	Pension	Supplemental Unemployment	Total Rate
1	50	\$19.81	\$8.25	\$0.00	\$0.00	\$28.06
2	55	\$21.79	\$8.25	\$6.16	\$0.00	\$36.20
3	60	\$23.77	\$8.25	\$6.72	\$0.00	\$38.74
4	65	\$25.75	\$8.25	\$7.28	\$0.00	\$41.28
5	70	\$27.73	\$8.25	\$19.39	\$0.00	\$55.37
6	75	\$29.72	\$8.25	\$19.95	\$0.00	\$57.92
7	80	\$31.70	\$8.25	\$20.51	\$0.00	\$60.46
8	90	\$35.66	\$8.25	\$21.63	\$0.00	\$65.54

Notes:

Steps are 750 hrs.

Apprentice to Journeyworker Ratio:1:1

PAINTER TRAFFIC MARKINGS (HEAVY/HIGHWAY)	06/01/2021	\$40.67	\$8.60	\$17.57	\$0.00	\$66.84
LABORERS - ZONE 1 (HEAVY & HIGHWAY)	12/01/2021	\$41.68	\$8.60	\$17.57	\$0.00	\$67.85
For apprentice rates see "Apprentice- LABORER (Heavy and Highway)						
PANEL & PICKUP TRUCKS DRIVER	06/01/2021	\$36.88	\$12.91	\$14.82	\$0.00	\$64.61
TEAMSTERS JOINT COUNCIL NO. 10 ZONE A	08/01/2021	\$36.88	\$13.41	\$14.82	\$0.00	\$65.11
	12/01/2021	\$36.88	\$13.41	\$16.01	\$0.00	\$66.30
PIER AND DOCK CONSTRUCTOR (UNDERPINNING AND DECK)	08/01/2020	\$49.07	\$9.40	\$23.12	\$0.00	\$81.59
PILE DRIVER LOCAL 56 (ZONE 1)						
For apprentice rates see "Apprentice- PILE DRIVER"						
PILE DRIVER	08/01/2020	\$49.07	\$9.40	\$23.12	\$0.00	\$81.59
PILE DRIVER LOCAL 56 (ZONE 1)						

Apprentice - PILE DRIVER - Local 56 Zone 1

Effective Date - 08/01/2020

Step	percent	Apprentice Base Wage	Health	Pension	Supplemental Unemployment	Total Rate
1	50	\$24.54	\$9.40	\$23.12	\$0.00	\$57.06
2	60	\$29.44	\$9.40	\$23.12	\$0.00	\$61.96
3	70	\$34.35	\$9.40	\$23.12	\$0.00	\$66.87
4	75	\$36.80	\$9.40	\$23.12	\$0.00	\$69.32
5	80	\$39.26	\$9.40	\$23.12	\$0.00	\$71.78
6	80	\$39.26	\$9.40	\$23.12	\$0.00	\$71.78
7	90	\$44.16	\$9.40	\$23.12	\$0.00	\$76.68
8	90	\$44.16	\$9.40	\$23.12	\$0.00	\$76.68

Notes:

% Indentured After 10/1/17; 45/45/55/55/70/70/80/80
Step 1&2 \$34.01/ 3&4 \$41.46/ 5&6 \$62.80/ 7&8 \$69.25

Apprentice to Journeyworker Ratio:1:5

Issue Date: 07/12/2021

Wage Request Number: 20210712-042

Page 23 of 32

Classification	Effective Date	Base Wage	Health	Pension	Supplemental Unemployment	Total Rate
PIPEFITTER & STEAMFITTER <i>PIPEFITTERS LOCAL 537</i>	03/01/2021	\$57.94	\$11.70	\$20.24	\$0.00	\$89.88

Apprentice - PIPEFITTER - Local 537

Effective Date - 03/01/2021

Step	percent	Apprentice Base Wage	Health	Pension	Supplemental Unemployment	Total Rate
1	40	\$23.18	\$11.70	\$8.25	\$0.00	\$43.13
2	45	\$26.07	\$11.70	\$20.24	\$0.00	\$58.01
3	60	\$34.76	\$11.70	\$20.24	\$0.00	\$66.70
4	70	\$40.56	\$11.70	\$20.24	\$0.00	\$72.50
5	80	\$46.35	\$11.70	\$20.24	\$0.00	\$78.29

Notes:

** 1:3; 3:15; 1:10 thereafter / Steps are 1 yr.
Refrig/AC Mechanic **1:1;1:2;2:4;3:6;4:8;5:10;6:12;7:14;8:17;9:20;10:23(Max)

Apprentice to Journeyworker Ratio:**

PIPELAYER <i>LABORERS - ZONE 1</i>	06/01/2021	\$40.92	\$8.60	\$17.57	\$0.00	\$67.09
	12/01/2021	\$41.93	\$8.60	\$17.57	\$0.00	\$68.10
	06/01/2022	\$42.93	\$8.60	\$17.57	\$0.00	\$69.10
	12/01/2022	\$43.93	\$8.60	\$17.57	\$0.00	\$70.10
	06/01/2023	\$44.93	\$8.60	\$17.57	\$0.00	\$71.10
	12/01/2023	\$46.18	\$8.60	\$17.57	\$0.00	\$72.35

For apprentice rates see "Apprentice- LABORER"

PIPELAYER (HEAVY & HIGHWAY) <i>LABORERS - ZONE 1 (HEAVY & HIGHWAY)</i>	06/01/2021	\$40.92	\$8.60	\$17.57	\$0.00	\$67.09
	12/01/2021	\$41.93	\$8.60	\$17.57	\$0.00	\$68.10

For apprentice rates see "Apprentice- LABORER (Heavy and Highway)"

PLUMBERS & GASFITTERS <i>PLUMBERS & GASFITTERS LOCAL 12</i>	03/01/2021	\$60.19	\$13.57	\$17.26	\$0.00	\$91.02
--	------------	---------	---------	---------	--------	---------

Apprentice - PLUMBER/GASFITTER - Local 12

Effective Date - 03/01/2021

Step	percent	Apprentice Base Wage	Health	Pension	Supplemental Unemployment	Total Rate
1	35	\$21.07	\$13.57	\$6.24	\$0.00	\$40.88
2	40	\$24.08	\$13.57	\$7.08	\$0.00	\$44.73
3	55	\$33.10	\$13.57	\$9.63	\$0.00	\$56.30
4	65	\$39.12	\$13.57	\$11.33	\$0.00	\$64.02
5	75	\$45.14	\$13.57	\$13.03	\$0.00	\$71.74

Notes:

** 1:2; 2:6; 3:10; 4:14; 5:19/Steps are 1 yr
Step4 with lic\$67.89, Step5 with lic\$75.59

Apprentice to Journeyworker Ratio:**

PNEUMATIC CONTROLS (TEMP.) <i>PIPEFITTERS LOCAL 537</i>	03/01/2021	\$57.94	\$11.70	\$20.24	\$0.00	\$89.88
--	------------	---------	---------	---------	--------	---------

For apprentice rates see "Apprentice- PIPEFITTER" or "PLUMBER/PIPEFITTER"

Issue Date: 07/12/2021

Wage Request Number: 20210712-042

Page 24 of 32

Classification	Effective Date	Base Wage	Health	Pension	Supplemental Unemployment	Total Rate
PNEUMATIC DRILL/TOOL OPERATOR <i>LABORERS - ZONE 1</i>	06/01/2021	\$40.92	\$8.60	\$17.57	\$0.00	\$67.09
	12/01/2021	\$41.93	\$8.60	\$17.57	\$0.00	\$68.10
	06/01/2022	\$42.93	\$8.60	\$17.57	\$0.00	\$69.10
	12/01/2022	\$43.93	\$8.60	\$17.57	\$0.00	\$70.10
	06/01/2023	\$44.93	\$8.60	\$17.57	\$0.00	\$71.10
	12/01/2023	\$46.18	\$8.60	\$17.57	\$0.00	\$72.35
For apprentice rates see "Apprentice- LABORER"						
PNEUMATIC DRILL/TOOL OPERATOR (HEAVY & HIGHWAY) <i>LABORERS - ZONE 1 (HEAVY & HIGHWAY)</i>	06/01/2021	\$40.92	\$8.60	\$17.57	\$0.00	\$67.09
	12/01/2021	\$41.93	\$8.60	\$17.57	\$0.00	\$68.10
For apprentice rates see "Apprentice- LABORER (Heavy and Highway)"						
POWDERMAN & BLASTER <i>LABORERS - ZONE 1</i>	06/01/2021	\$41.67	\$8.60	\$17.57	\$0.00	\$67.84
	12/01/2021	\$42.68	\$8.60	\$17.57	\$0.00	\$68.85
	06/01/2022	\$43.68	\$8.60	\$17.57	\$0.00	\$69.85
	12/01/2022	\$44.68	\$8.60	\$17.57	\$0.00	\$70.85
	06/01/2023	\$45.68	\$8.60	\$17.57	\$0.00	\$71.85
	12/01/2023	\$46.93	\$8.60	\$17.57	\$0.00	\$73.10
For apprentice rates see "Apprentice- LABORER"						
POWDERMAN & BLASTER (HEAVY & HIGHWAY) <i>LABORERS - ZONE 1 (HEAVY & HIGHWAY)</i>	06/01/2021	\$41.67	\$8.60	\$17.57	\$0.00	\$67.84
	12/01/2021	\$42.68	\$8.60	\$17.57	\$0.00	\$68.85
For apprentice rates see "Apprentice- LABORER (Heavy and Highway)"						
POWER SHOVEL/DERRICK/TRENCHING MACHINE <i>OPERATING ENGINEERS LOCAL 4</i>	06/01/2021	\$50.73	\$13.75	\$15.80	\$0.00	\$80.28
	12/01/2021	\$51.88	\$13.75	\$15.80	\$0.00	\$81.43
For apprentice rates see "Apprentice- OPERATING ENGINEERS"						
PUMP OPERATOR (CONCRETE) <i>OPERATING ENGINEERS LOCAL 4</i>	06/01/2021	\$50.73	\$13.75	\$15.80	\$0.00	\$80.28
	12/01/2021	\$51.88	\$13.75	\$15.80	\$0.00	\$81.43
For apprentice rates see "Apprentice- OPERATING ENGINEERS"						
PUMP OPERATOR (DEWATERING, OTHER) <i>OPERATING ENGINEERS LOCAL 4</i>	06/01/2021	\$33.40	\$13.75	\$15.80	\$0.00	\$62.95
	12/01/2021	\$34.19	\$13.75	\$15.80	\$0.00	\$63.74
For apprentice rates see "Apprentice- OPERATING ENGINEERS"						
READY-MIX CONCRETE DRIVER <i>TEAMSTERS 170 - Rosenfeld (Walpole)</i>	05/01/2021	\$25.00	\$11.51	\$8.00	\$0.00	\$44.51
	01/01/2022	\$25.00	\$11.96	\$8.00	\$0.00	\$44.96
	05/01/2022	\$25.75	\$11.96	\$8.00	\$0.00	\$45.71
	01/01/2023	\$25.75	\$12.46	\$8.00	\$0.00	\$46.21
	05/01/2023	\$26.40	\$12.46	\$8.00	\$0.00	\$46.86
	01/01/2024	\$26.40	\$12.96	\$8.00	\$0.00	\$47.36
	05/01/2024	\$27.00	\$12.96	\$8.00	\$0.00	\$47.96
	01/01/2025	\$27.00	\$13.46	\$8.00	\$0.00	\$48.46
	05/01/2025	\$27.60	\$13.46	\$8.25	\$0.00	\$49.31
01/01/2026	\$27.60	\$13.96	\$8.25	\$0.00	\$49.81	
RECLAIMERS <i>OPERATING ENGINEERS LOCAL 4</i>	06/01/2021	\$50.19	\$13.75	\$15.80	\$0.00	\$79.74
	12/01/2021	\$51.33	\$13.75	\$15.80	\$0.00	\$80.88
For apprentice rates see "Apprentice- OPERATING ENGINEERS"						

Classification	Effective Date	Base Wage	Health	Pension	Supplemental Unemployment	Total Rate
RIDE-ON MOTORIZED BUGGY OPERATOR <i>LABORERS - ZONE 1</i>	06/01/2021	\$40.92	\$8.60	\$17.57	\$0.00	\$67.09
	12/01/2021	\$41.93	\$8.60	\$17.57	\$0.00	\$68.10
	06/01/2022	\$42.93	\$8.60	\$17.57	\$0.00	\$69.10
	12/01/2022	\$43.93	\$8.60	\$17.57	\$0.00	\$70.10
	06/01/2023	\$44.93	\$8.60	\$17.57	\$0.00	\$71.10
	12/01/2023	\$46.18	\$8.60	\$17.57	\$0.00	\$72.35
For apprentice rates see "Apprentice- LABORER"						
ROLLER/SPREADER/MULCHING MACHINE <i>OPERATING ENGINEERS LOCAL 4</i>	06/01/2021	\$50.19	\$13.75	\$15.80	\$0.00	\$79.74
	12/01/2021	\$51.33	\$13.75	\$15.80	\$0.00	\$80.88
For apprentice rates see "Apprentice- OPERATING ENGINEERS"						
ROOFER (Inc.Roofer Waterproofing & Roofer Damproofg) <i>ROOFERS LOCAL 33</i>	02/01/2021	\$46.60	\$12.28	\$17.15	\$0.00	\$76.03
	08/01/2021	\$48.03	\$12.28	\$17.15	\$0.00	\$77.46
	02/01/2022	\$49.46	\$12.28	\$17.15	\$0.00	\$78.89

Apprentice - ROOFER - Local 33

Effective Date - 02/01/2021

Step	percent	Apprentice Base Wage	Health	Pension	Supplemental Unemployment	Total Rate
1	50	\$23.30	\$12.28	\$4.31	\$0.00	\$39.89
2	60	\$27.96	\$12.28	\$17.15	\$0.00	\$57.39
3	65	\$30.29	\$12.28	\$17.15	\$0.00	\$59.72
4	75	\$34.95	\$12.28	\$17.15	\$0.00	\$64.38
5	85	\$39.61	\$12.28	\$17.15	\$0.00	\$69.04

Effective Date - 08/01/2021

Step	percent	Apprentice Base Wage	Health	Pension	Supplemental Unemployment	Total Rate
1	50	\$24.02	\$12.28	\$4.31	\$0.00	\$40.61
2	60	\$28.82	\$12.28	\$17.15	\$0.00	\$58.25
3	65	\$31.22	\$12.28	\$17.15	\$0.00	\$60.65
4	75	\$36.02	\$12.28	\$17.15	\$0.00	\$65.45
5	85	\$40.83	\$12.28	\$17.15	\$0.00	\$70.26

Notes: ** 1:5, 2:6-10, the 1:10; Reroofing: 1:4, then 1:1
 Step 1 is 2000 hrs.; Steps 2-5 are 1000 hrs.
 (Hot Pitch Mechanics' receive \$1.00 hr. above ROOFER)

Apprentice to Journeyworker Ratio:**

ROOFER SLATE / TILE / PRECAST CONCRETE <i>ROOFERS LOCAL 33</i>	02/01/2021	\$46.85	\$12.28	\$17.15	\$0.00	\$76.28
	08/01/2021	\$48.28	\$12.28	\$17.15	\$0.00	\$77.71
	02/01/2022	\$49.71	\$12.28	\$17.15	\$0.00	\$79.14
For apprentice rates see "Apprentice- ROOFER"						
SHEETMETAL WORKER <i>SHEETMETAL WORKERS LOCAL 17 - A</i>	02/01/2021	\$51.67	\$13.65	\$24.57	\$2.70	\$92.59
	08/01/2021	\$53.42	\$13.65	\$24.57	\$2.75	\$94.39
	02/01/2022	\$55.17	\$13.65	\$24.57	\$2.80	\$96.19

Issue Date: 07/12/2021

Wage Request Number: 20210712-042

Page 26 of 32

Classification

Effective Date Base Wage Health Pension Supplemental Unemployment Total Rate

Apprentice - SPRINKLER FITTER - Local 550 (Section A) Zone 1

Effective Date - 03/01/2021

Step	percent	Apprentice Base Wage	Health	Pension	Supplemental Unemployment	Total Rate
1	35	\$21.86	\$10.00	\$11.99	\$0.00	\$43.85
2	40	\$24.98	\$10.00	\$12.70	\$0.00	\$47.68
3	45	\$28.10	\$10.00	\$13.41	\$0.00	\$51.51
4	50	\$31.23	\$10.00	\$14.13	\$0.00	\$55.36
5	55	\$34.35	\$10.00	\$14.84	\$0.00	\$59.19
6	60	\$37.47	\$10.00	\$15.55	\$0.00	\$63.02
7	65	\$40.59	\$10.00	\$16.26	\$0.00	\$66.85
8	70	\$43.72	\$10.00	\$16.98	\$0.00	\$70.70
9	75	\$46.84	\$10.00	\$17.69	\$0.00	\$74.53
10	80	\$49.96	\$10.00	\$18.40	\$0.00	\$78.36

Notes: Apprentice entered prior 9/30/10:
40/45/50/55/60/65/70/75/80/85
Steps are 850 hours

Apprentice to Journeyworker Ratio:1:3

STEAM BOILER OPERATOR OPERATING ENGINEERS LOCAL 4	06/01/2021	\$50.19	\$13.75	\$15.80	\$0.00	\$79.74
	12/01/2021	\$51.33	\$13.75	\$15.80	\$0.00	\$80.88
For apprentice rates see "Apprentice- OPERATING ENGINEERS"						
TAMPERS, SELF-PROPELLED OR TRACTOR DRAWN OPERATING ENGINEERS LOCAL 4	06/01/2021	\$50.19	\$13.75	\$15.80	\$0.00	\$79.74
	12/01/2021	\$51.33	\$13.75	\$15.80	\$0.00	\$80.88
For apprentice rates see "Apprentice- OPERATING ENGINEERS"						
TELECOMMUNICATION TECHNICIAN ELECTRICIANS LOCAL 103	03/01/2021	\$42.11	\$13.00	\$17.88	\$0.00	\$72.99
	09/01/2021	\$43.77	\$13.00	\$18.00	\$0.00	\$74.77
	03/01/2022	\$45.27	\$13.00	\$18.12	\$0.00	\$76.39
	09/01/2022	\$46.99	\$13.00	\$18.24	\$0.00	\$78.23
	03/01/2023	\$48.54	\$13.00	\$18.37	\$0.00	\$79.91

Classification

Effective Date Base Wage Health Pension Supplemental Unemployment Total Rate

Apprentice - TELECOMMUNICATION TECHNICIAN - Local 103

Effective Date - 03/01/2021

Step	percent	Apprentice Base Wage	Health	Pension	Supplemental Unemployment	Total Rate
1	45	\$18.95	\$13.00	\$0.57	\$0.00	\$32.52
2	45	\$18.95	\$13.00	\$0.57	\$0.00	\$32.52
3	50	\$21.06	\$13.00	\$14.51	\$0.00	\$48.57
4	50	\$21.06	\$13.00	\$14.51	\$0.00	\$48.57
5	55	\$23.16	\$13.00	\$14.84	\$0.00	\$51.00
6	60	\$25.27	\$13.00	\$15.18	\$0.00	\$53.45
7	65	\$27.37	\$13.00	\$15.52	\$0.00	\$55.89
8	70	\$29.48	\$13.00	\$15.85	\$0.00	\$58.33
9	75	\$31.58	\$13.00	\$16.20	\$0.00	\$60.78
10	80	\$33.69	\$13.00	\$16.53	\$0.00	\$63.22

Effective Date - 09/01/2021

Step	percent	Apprentice Base Wage	Health	Pension	Supplemental Unemployment	Total Rate
1	45	\$19.70	\$13.00	\$0.59	\$0.00	\$33.29
2	45	\$19.70	\$13.00	\$0.59	\$0.00	\$33.29
3	50	\$21.89	\$13.00	\$14.57	\$0.00	\$49.46
4	50	\$21.89	\$13.00	\$14.57	\$0.00	\$49.46
5	55	\$24.07	\$13.00	\$14.91	\$0.00	\$51.98
6	60	\$26.26	\$13.00	\$15.26	\$0.00	\$54.52
7	65	\$28.45	\$13.00	\$15.59	\$0.00	\$57.04
8	70	\$30.64	\$13.00	\$15.94	\$0.00	\$59.58
9	75	\$32.83	\$13.00	\$16.28	\$0.00	\$62.11
10	80	\$35.02	\$13.00	\$16.63	\$0.00	\$64.65

Notes:

Apprentice to Journeyworker Ratio:1:1

TERRAZZO FINISHERS	02/01/2021	\$54.69	\$11.39	\$22.09	\$0.00	\$88.17
BRICKLAYERS LOCAL 3 - MARBLE & TILE	08/01/2021	\$56.09	\$11.39	\$22.25	\$0.00	\$89.73
	02/01/2022	\$56.68	\$11.39	\$22.25	\$0.00	\$90.32

Classification

Effective Date Base Wage Health Pension Supplemental Unemployment Total Rate

Apprentice - TERRAZZO FINISHER - Local 3 Marble & Tile

Effective Date - 02/01/2021

Step	percent	Apprentice Base Wage	Health	Pension	Supplemental Unemployment	Total Rate
1	50	\$27.35	\$11.39	\$22.09	\$0.00	\$60.83
2	60	\$32.81	\$11.39	\$22.09	\$0.00	\$66.29
3	70	\$38.28	\$11.39	\$22.09	\$0.00	\$71.76
4	80	\$43.75	\$11.39	\$22.09	\$0.00	\$77.23
5	90	\$49.22	\$11.39	\$22.09	\$0.00	\$82.70

Effective Date - 08/01/2021

Step	percent	Apprentice Base Wage	Health	Pension	Supplemental Unemployment	Total Rate
1	50	\$28.05	\$11.39	\$22.25	\$0.00	\$61.69
2	60	\$33.65	\$11.39	\$22.25	\$0.00	\$67.29
3	70	\$39.26	\$11.39	\$22.25	\$0.00	\$72.90
4	80	\$44.87	\$11.39	\$22.25	\$0.00	\$78.51
5	90	\$50.48	\$11.39	\$22.25	\$0.00	\$84.12

Notes:

Apprentice to Journeyworker Ratio:1:3

TEST BORING DRILLER <i>LABORERS - FOUNDATION AND MARINE</i>	06/01/2021	\$42.07	\$8.60	\$17.72	\$0.00	\$68.39
For apprentice rates see "Apprentice- LABORER"	12/01/2021	\$43.08	\$8.60	\$17.72	\$0.00	\$69.40
TEST BORING DRILLER HELPER <i>LABORERS - FOUNDATION AND MARINE</i>	06/01/2021	\$40.79	\$8.60	\$17.72	\$0.00	\$67.11
For apprentice rates see "Apprentice- LABORER"	12/01/2021	\$41.80	\$8.60	\$17.72	\$0.00	\$68.12
TEST BORING LABORER <i>LABORERS - FOUNDATION AND MARINE</i>	06/01/2021	\$40.67	\$8.60	\$17.72	\$0.00	\$66.99
For apprentice rates see "Apprentice- LABORER"	12/01/2021	\$41.68	\$8.60	\$17.72	\$0.00	\$68.00
TRACTORS/PORTABLE STEAM GENERATORS <i>OPERATING ENGINEERS LOCAL 4</i>	06/01/2021	\$50.19	\$13.75	\$15.80	\$0.00	\$79.74
For apprentice rates see "Apprentice- OPERATING ENGINEERS"	12/01/2021	\$51.33	\$13.75	\$15.80	\$0.00	\$80.88
TRAILERS FOR EARTH MOVING EQUIPMENT <i>TEAMSTERS JOINT COUNCIL NO. 10 ZONE A</i>	06/01/2021	\$37.92	\$12.91	\$14.82	\$0.00	\$65.65
	08/01/2021	\$37.92	\$13.41	\$14.82	\$0.00	\$66.15
	12/01/2021	\$37.92	\$13.41	\$16.01	\$0.00	\$67.34
TUNNEL WORK - COMPRESSED AIR <i>LABORERS (COMPRESSED AIR)</i>	06/01/2021	\$52.90	\$8.60	\$18.17	\$0.00	\$79.67
For apprentice rates see "Apprentice- LABORER"	12/01/2021	\$53.91	\$8.60	\$18.17	\$0.00	\$80.68
TUNNEL WORK - COMPRESSED AIR (HAZ. WASTE) <i>LABORERS (COMPRESSED AIR)</i>	06/01/2021	\$54.90	\$8.60	\$18.17	\$0.00	\$81.67
For apprentice rates see "Apprentice- LABORER"	12/01/2021	\$55.91	\$8.60	\$18.17	\$0.00	\$82.68
TUNNEL WORK - FREE AIR <i>LABORERS (FREE AIR TUNNEL)</i>	06/01/2021	\$44.97	\$8.60	\$18.17	\$0.00	\$71.74
For apprentice rates see "Apprentice- LABORER"	12/01/2021	\$45.98	\$8.60	\$18.17	\$0.00	\$72.75

Issue Date: 07/12/2021

Wage Request Number: 20210712-042

Page 30 of 32

Classification	Effective Date	Base Wage	Health	Pension	Supplemental Unemployment	Total Rate
TUNNEL WORK - FREE AIR (HAZ. WASTE) <i>LABORERS (FREE AIR TUNNEL)</i>	06/01/2021	\$46.97	\$8.60	\$18.17	\$0.00	\$73.74
	12/01/2021	\$47.98	\$8.60	\$18.17	\$0.00	\$74.75
For apprentice rates see "Apprentice- LABORER"						
VAC-HAUL <i>TEAMSTERS JOINT COUNCIL NO. 10 ZONE A</i>	06/01/2021	\$37.34	\$12.91	\$14.82	\$0.00	\$65.07
	08/01/2021	\$37.34	\$13.41	\$14.82	\$0.00	\$65.57
	12/01/2021	\$37.34	\$13.41	\$16.01	\$0.00	\$66.76
WAGON DRILL OPERATOR <i>LABORERS - ZONE 1</i>	06/01/2021	\$40.92	\$8.60	\$17.57	\$0.00	\$67.09
	12/01/2021	\$41.93	\$8.60	\$17.57	\$0.00	\$68.10
	06/01/2022	\$42.93	\$8.60	\$17.57	\$0.00	\$69.10
	12/01/2022	\$43.93	\$8.60	\$17.57	\$0.00	\$70.10
	06/01/2023	\$44.93	\$8.60	\$17.57	\$0.00	\$71.10
	12/01/2023	\$46.18	\$8.60	\$17.57	\$0.00	\$72.35
For apprentice rates see "Apprentice- LABORER"						
WAGON DRILL OPERATOR (HEAVY & HIGHWAY) <i>LABORERS - ZONE 1 (HEAVY & HIGHWAY)</i>	06/01/2021	\$40.92	\$8.60	\$17.57	\$0.00	\$67.09
	12/01/2021	\$41.93	\$8.60	\$17.57	\$0.00	\$68.10
For apprentice rates see "Apprentice- LABORER (Heavy and Highway)"						
WASTE WATER PUMP OPERATOR <i>OPERATING ENGINEERS LOCAL 4</i>	06/01/2021	\$50.73	\$13.75	\$15.80	\$0.00	\$80.28
	12/01/2021	\$51.88	\$13.75	\$15.80	\$0.00	\$81.43
For apprentice rates see "Apprentice- OPERATING ENGINEERS"						
WATER METER INSTALLER <i>PLUMBERS & GASFITTERS LOCAL 12</i>	03/01/2021	\$60.19	\$13.57	\$17.26	\$0.00	\$91.02
For apprentice rates see "Apprentice- PLUMBER/PIPEFITTER" or "PLUMBER/GASFITTER"						
Outside Electrical - East						
CABLE TECHNICIAN (Power Zone) <i>OUTSIDE ELECTRICAL WORKERS - EAST LOCAL 104</i>	08/30/2020	\$29.67	\$9.25	\$1.89	\$0.00	\$40.81
For apprentice rates see "Apprentice- LINEMAN"						
CABLEMAN (Underground Ducts & Cables) <i>OUTSIDE ELECTRICAL WORKERS - EAST LOCAL 104</i>	08/30/2020	\$42.03	\$9.25	\$10.27	\$0.00	\$61.55
For apprentice rates see "Apprentice- LINEMAN"						
DRIVER / GROUNDMAN CDL <i>OUTSIDE ELECTRICAL WORKERS - EAST LOCAL 104</i>	08/30/2020	\$34.62	\$9.25	\$10.07	\$0.00	\$53.94
For apprentice rates see "Apprentice- LINEMAN"						
DRIVER / GROUNDMAN -Inexperienced (<2000 Hrs) <i>OUTSIDE ELECTRICAL WORKERS - EAST LOCAL 104</i>	08/30/2020	\$27.20	\$9.25	\$1.82	\$0.00	\$38.27
For apprentice rates see "Apprentice- LINEMAN"						
EQUIPMENT OPERATOR (Class A CDL) <i>OUTSIDE ELECTRICAL WORKERS - EAST LOCAL 104</i>	08/30/2020	\$42.03	\$9.25	\$14.35	\$0.00	\$65.63
For apprentice rates see "Apprentice- LINEMAN"						
EQUIPMENT OPERATOR (Class B CDL) <i>OUTSIDE ELECTRICAL WORKERS - EAST LOCAL 104</i>	08/30/2020	\$37.09	\$9.25	\$10.87	\$0.00	\$57.21
For apprentice rates see "Apprentice- LINEMAN"						
GROUNDMAN <i>OUTSIDE ELECTRICAL WORKERS - EAST LOCAL 104</i>	08/30/2020	\$27.20	\$9.25	\$1.82	\$0.00	\$38.27
For apprentice rates see "Apprentice- LINEMAN"						
GROUNDMAN -Inexperienced (<2000 Hrs.) <i>OUTSIDE ELECTRICAL WORKERS - EAST LOCAL 104</i>	08/30/2020	\$22.25	\$9.25	\$1.82	\$0.00	\$33.32
For apprentice rates see "Apprentice- LINEMAN"						
JOURNEYMAN LINEMAN <i>OUTSIDE ELECTRICAL WORKERS - EAST LOCAL 104</i>	08/30/2020	\$49.45	\$9.25	\$17.48	\$0.00	\$76.18

Issue Date: 07/12/2021

Wage Request Number: 20210712-042

Page 31 of 32

Classification

Effective Date Base Wage Health Pension Supplemental Unemployment Total Rate

Apprentice - LINEMAN (Outside Electrical) - East Local 104

Effective Date - 08/30/2020

Step	percent	Apprentice Base Wage	Health	Pension	Supplemental Unemployment	Total Rate
1	60	\$29.67	\$9.25	\$3.39	\$0.00	\$42.31
2	65	\$32.14	\$9.25	\$3.46	\$0.00	\$44.85
3	70	\$34.62	\$9.25	\$3.54	\$0.00	\$47.41
4	75	\$37.09	\$9.25	\$5.11	\$0.00	\$51.45
5	80	\$39.56	\$9.25	\$5.19	\$0.00	\$54.00
6	85	\$42.03	\$9.25	\$5.26	\$0.00	\$56.54
7	90	\$44.51	\$9.25	\$7.34	\$0.00	\$61.10

Notes:

Apprentice to Journeyworker Ratio:1:2

TELEDATA CABLE SPLICER <i>OUTSIDE ELECTRICAL WORKERS - EAST LOCAL 104</i>	02/04/2019	\$30.73	\$4.70	\$3.17	\$0.00	\$38.60
TELEDATA LINEMAN/EQUIPMENT OPERATOR <i>OUTSIDE ELECTRICAL WORKERS - EAST LOCAL 104</i>	02/04/2019	\$28.93	\$4.70	\$3.14	\$0.00	\$36.77
TELEDATA WIREMAN/INSTALLER/TECHNICIAN <i>OUTSIDE ELECTRICAL WORKERS - EAST LOCAL 104</i>	02/04/2019	\$28.93	\$4.70	\$3.14	\$0.00	\$36.77

Additional Apprentice Information:

Minimum wage rates for apprentices employed on public works projects are listed above as a percentage of the pre-determined hourly wage rate established by the Commissioner under the provisions of the M.G.L. c. 149, ss. 26-27D. Apprentice ratios are established by the Division of Apprenticeship Training pursuant to M.G.L. c. 23, ss. 11E-11L.

All apprentices must be registered with the Division of Apprenticeship Training in accordance with M.G.L. c. 23, ss. 11E-11L.

All steps are six months (1000 hours.)

Ratios are expressed in allowable number of apprentices to journeymen or fraction thereof, unless otherwise specified.

** Multiple ratios are listed in the comment field.

*** APP to JM; 1:1, 2:2, 2:3, 3:4, 4:4, 4:5, 4:6, 5:7, 6:7, 6:8, 6:9, 7:10, 8:10, 8:11, 8:12, 9:13, 10:13, 10:14, etc.

**** APP to JM; 1:1, 1:2, 2:3, 2:4, 3:5, 4:6, 4:7, 5:8, 6:9, 6:10, 7:11, 8:12, 8:13, 9:14, 10:15, 10:16, etc.

The Massachusetts Prevailing Wage Law

M.G.L. ch. 149, §§ 26 – 27

NOTICE TO AWARDING AUTHORITIES

- 'The enclosed wage schedule applies only to the specific project listed at the top and will be updated for any public construction project lasting longer than one (1) year.
- 'You should request an updated wage schedule from the Division of Occupational Safety if you have not opened bids or selected a contractor within 90 days of the date of issuance of the enclosed wage schedule.
- 'The wage schedule shall be incorporated in any advertisement or call for bids for the project for which it has been issued.
- 'Once a contractor has been selected by the awarding authority, the wage schedule shall be made a part of the contract for that project.

NOTICE TO CONTRACTORS

- The enclosed wage schedule, and any updated schedule, must be posted in a conspicuous place at the work site during the life of the project.
- The wages listed on the enclosed wage schedule must be paid to employees on public works projects regardless of whether they are employed by the prime contractor, a filed sub-bidder, or any sub-contractor.
- The enclosed wage schedule applies to all phases of the project including the final clean-up. Contractors whose only role is to perform final clean-up must pay their employees according to this wage schedule.
- All apprentices must be registered with the Massachusetts Division of Apprentice Training in order to be paid at the reduced apprentice rates. If a worker is not registered with the Division of Apprentice Training, they must be paid the “total rate” listed on the wage schedule regardless of experience or skill level. For further information, please call (617) 727-3486 or write to the Division of Apprentice Training, 399 Washington Street, 4th Floor, Boston, MA 02108

**WEEKLY PAYROLL RECORDS REPORT
& STATEMENT OF COMPLIANCE**

In accordance with Massachusetts General Law c149, §27B, a true and accurate record must be kept of all persons employed on the public works project for which the enclosed rates have been provided. A Payroll Form has been printed on the reverse of this page and includes all the information required to be kept by law. Every contractor or subcontractor is required to keep these records and preserve them for a period of three years from the date of completion of the contract.

In addition, every contractor and subcontractor is required to submit a copy of their weekly payroll records to the awarding authority. This is required to be done on a weekly basis. Once collected, the awarding authority is also required to preserve those records for three years.

In addition, each such contractor, subcontractor or public body shall furnish to the Department of Labor & Workforce Development/Division of Occupational Safety within fifteen days after completion of its portion of the work a statement, executed by the contractor, subcontractor or public body who supervises the payment of wages, in the following form:

STATEMENT OF COMPLIANCE

_____, 2021

I, _____,
(Name of signatory party) (Title)

do hereby state:

That I pay or supervise the payment of the persons employed by

_____ on the _____
(Contractor, subcontractor or public body) (Building or project)

and that all mechanics and apprentices, teamsters, chauffeurs and laborers employed on said project have been paid in accordance with wages determined under the provisions of sections twenty-six and twenty-seven of chapter one hundred and forty nine of the General Laws.

Signature _____

Title _____

DIVISION OF OCCUPATIONAL SAFETY, 399 WASHINGTON STREET, 5TH FL., BOSTON, MA. 02108

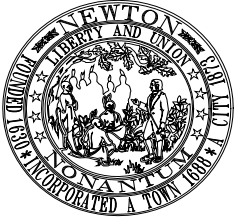

City of Newton

Massachusetts 02459

Engineering Division

Phone (617) 796-1020

FAX (617) 796-1051

Permit Number _____

Date Issued _____

Expiration Date _____

Fee: \$50 x _____ = _____
Trenches Total

TRENCH
 Pursuant to G.L.

PERMIT
 c. 82A §1 and 520 CMR 7.00 et seq.(as amended)

THIS PERMIT MUST BE FULLY COMPLETED PRIOR TO CONSIDERATION

Name of Applicant			Phone	Cell
Street Address				
City/Town	MA	ZIP		
Name of Excavator (if different from applicant)			Phone	Cell
Street Address				
City/Town	MA	ZIP		
Name of Owner(s) of Property			Phone	Cell
Street Address				
City/Town	MA	ZIP		
Other Contact			Permit Fee Received No () Yes ()	
Description, location and purpose of proposed trench: Please describe the exact location of the proposed trench and its purpose (include a description of what is (or is intended) to be laid in proposed trench (e.g.; pipes/cable lines etc.) Please use reverse side if additional space is needed.				
Insurance Certificate #:				
Name and Contact Information of Insurer:				
Policy Expiration Date:				
Dig Safe #:				

Name of Competent Person (as defined by 520 CMR 7.02):	
Massachusetts Hoisting License #	
License Grade:	Expiration Date:

BY SIGNING THIS FORM, THE APPLICANT, OWNER, AND EXCAVATOR ALL ACKNOWLEDGE AND CERTIFY THAT THEY ARE FAMILIAR WITH, OR, BEFORE COMMENCEMENT OF THE WORK, WILL BECOME FAMILIAR WITH, ALL LAWS AND REGULATIONS APPLICABLE TO WORK PROPOSED, INCLUDING OSHA REGULATIONS, G.L. c. 82A, 520 CMR 7.00 et seq., AND ANY APPLICABLE MUNICIPAL ORDINANCES, BY-LAWS AND REGULATIONS AND THEY COVENANT AND AGREE THAT ALL WORK DONE UNDER THE PERMIT ISSUED FOR SUCH WORK WILL COMPLY THEREWITH IN ALL RESPECTS AND WITH THE CONDITIONS SET FORTH BELOW.

THE UNDERSIGNED OWNER AUTHORIZES THE APPLICANT TO APPLY FOR THE PERMIT AND THE EXCAVATOR TO UNDERTAKE SUCH WORK ON THE PROPERTY OF THE OWNER, AND ALSO, FOR THE DURATION OF CONSTRUCTION, AUTHORIZES PERSONS DULY APPOINTED BY THE MUNICIPALITY TO ENTER UPON THE PROPERTY TO MONITOR AND INSPECT THE WORK FOR CONFORMITY WITH THE CONDITIONS ATTACHED HERETO AND THE LAWS AND REGULATIONS GOVERING SUCH WORK.

THE UNDERSIGNED APPLICANT, OWNER AND EXCAVATOR AGREE JOINTLY AND SEVERALLY TO REIMBURSE THE MUNICIPALITY FOR ANY AND ALL COSTS AND EXPENSES INCURRED BY THE MUNICIPALITY IN CONNECTION WITH THIS PERMIT AND THE WORK CONDUCTED THEREUNDER, INCLUDING BUT NOT LIMITED TO ENFORCING THE REQUIREMENTS OF STATE LAW AND CONDITIONS OF THIS PERMIT, INSPECTIONS MADE TO ASSURE COMPLIANCE THEREWITH, AND MEASURES TAKEN BY THE MUNICIPALITY TO PROTECT THE PUBLIC WHERE THE APPLICANT OWNER OR EXCAVATOR HAS FAILED TO COMPLY THEREWITH INCLUDING POLICE DETAILS AND OTHER REMEDIAL MEASURES DEEMED NECESSARY BY THE MUNICIPALITY.

THE UNDERSIGNED APPLICANT, OWNER AND EXCAVATOR AGREE JOINTLY AND SEVERALLY TO DEFEND, INDEMNIFY, AND HOLD HARMLESS THE MUNICIPALITY AND ALL OF ITS AGENTS AND EMPLOYEES FROM ANY AND ALL LIABILITY, CAUSES OR ACTION, COSTS, AND EXPENSES RESULTING FROM OR ARISING OUT OF ANY INJURY, DEATH, LOSS, OR DAMAGE TO ANY PERSON OR PROPERTY DURING THE WORK CONDUCTED UNDER THIS PERMIT.

APPLICANT SIGNATURE

_____ **DATE** _____

EXCAVATOR SIGNATURE (IF DIFFERENT)

_____ **DATE** _____

OWNER'S SIGNATURE (IF DIFFERENT)

_____ **DATE:** _____

For City/Town use -- Do not write in this section	
PERMIT APPROVED BY	\$ _____ Application Fee
PERMITTING AUTHORITY	Date
CONDITIONS OF APPROVAL	

CONDITIONS AND REQUIREMENTS PURSUANT TO G.L.C.82A AND 520 CMR 7.00 et seq. (as amended)

By signing the application, the applicant understands and agrees to comply with the following:

- i. No trench may be excavated unless the requirements of sections 40 through 40D of chapter 82, and any accompanying regulations, have been met and this permit is invalid unless and until said requirements have been complied with by the excavator applying for the permit including, but not limited to, the establishment of a valid excavation number with the underground plant damage prevention system as said system is defined in section 76D of chapter 164 (DIG SAFE);
- ii. Trenches may pose a significant health and safety hazard. Pursuant to Section 1 of Chapter 82 of the General Laws, an excavator shall not leave any open trench unattended without first making every reasonable effort to eliminate any recognized safety hazard that may exist as a result of leaving said open trench unattended. Excavators should consult regulations promulgated by the Department of Public Safety in order to familiarize themselves with the recognized safety hazards associated with excavations and open trenches and the procedures required or recommended by said department in order to make every reasonable effort to eliminate said safety hazards which may include covering, barricading or otherwise protecting open trenches from accidental entry.
- iii. Persons engaging in any in any trenching operation shall familiarize themselves with the federal safety standards promulgated by the Occupational Safety and Health Administration on excavations: 29 CFR 1926.650 et seq., entitled Subpart P “Excavations”.
- iv. Excavators engaging in any trenching operation who utilize hoisting or other mechanical equipment subject to chapter 146 shall only employ individuals licensed to operate said equipment by the Department of Public Safety pursuant to said chapter and this permit must be presented to said licensed operator before any excavation is commenced;
- v. By applying for, accepting and signing this permit, the applicant hereby attests to the following: (1) that they have read and understands the regulations promulgated by the Department of Public Safety with regard to construction related excavations and trench safety; (2) that he has read and understands the federal safety standards promulgated by the Occupational Safety and Health Administration on excavations: 29 CMR 1926.650 et seq., entitled Subpart P “Excavations” as well as any other excavation requirements established by this municipality; and (3) that he is aware of and has, with regard to the proposed trench excavation on private property or proposed excavation of a city or town public way that forms the basis of the permit application, complied with the requirements of sections 40-40D of chapter 82A.
- vi. This permit shall be posted in plain view on the site of the trench.

Summary of Excavation and Trench Safety Regulation (520 CMR 14.00 et seq.)

This summary was prepared by the Massachusetts Department of Public Safety pursuant to G.L.c.82A and does not include all requirements of the 520 CMR 14.00. To view the full regulation and G.L.c.82A, go to www.mass.gov/dps

Pursuant to M.G.L. c. 82, § 1, the Department of Public Safety, jointly with the Division of Occupational Safety, drafted regulations relative to trench safety. The regulation is codified in section 14.00 of title 520 of the Code of Massachusetts Regulations. The regulation requires all excavators to obtain a permit prior to the excavation of a trench made for a construction-related purpose on public or private land or rights-of-way. All municipalities must establish a local permitting authority for the purpose of issuing permits for trenches within their municipality. Trenches on land owned or controlled by a public (state) agency requires a permit to be issued by that public agency unless otherwise designated.

In addition to the permitting requirements mandated by statute, the trench safety regulations require that all excavators, whether public or private, take specific precautions to protect the general public and prevent unauthorized access to unattended trenches. Accordingly, unattended trenches must be covered, barricaded or backfilled. Covers must be road plates at least ¾” thick or equivalent; barricades must be fences at least 6’ high with no openings greater than 4” between vertical supports; backfilling must be sufficient to eliminate the trench. Alternatively, excavators may choose to attend trenches at all times, for instance by hiring a police detail, security guard or other attendant who will be present during times when the trench will be unattended by the excavator.

The regulations further provide that local permitting authorities, the Department of Public Safety, or the Division of Occupational Safety may order an immediate shutdown of a trench in the event of a death or serious injury; the failure to obtain a permit; or the failure to implement or effectively use adequate protections for the general public. The trench shall remain shut down until re-inspected and authorized to re-open provided, however, that excavators shall have the right to appeal an immediate shutdown. Permitting authorities are further authorized to suspend or revoke a permit following a hearing. Excavators may also be subject to administrative fines issued by the Department of Public Safety for identified violations.

For additional information please visit the Department of Public Safety's website at www.mass.gov/dps

Summary of 1926 CFR Subpart P -OSHA Excavation Standard

This is a worker protection standard, and is designed to protect employees who are working inside a trench. This summary was prepared by the Massachusetts Division of Occupational Safety and not OSHA for informational purposes only and does not constitute an official interpretation by OSHA of their regulations, and may not include all aspects of the standard.

For further information or a full copy of the standard go to www.osha.gov.

- **Trench Definition per the OSHA standard:**
 - An excavation made below the surface of the ground, narrow in relation to its length.
 - In general, the depth is greater than the width, but the width of the trench is not greater than fifteen feet.
- **Protective Systems** to prevent soil wall collapse are always required in trenches deeper than 5', and are also required in trenches less than 5' deep when the competent person determines that a hazard exists. Protection options include:
 - Shoring. Shoring must be used in accordance with the OSHA Excavation standard appendices, the equipment manufacturer's tabulated data, or designed by a registered professional engineer.
 - Shielding (Trench Boxes). Trench boxes must be used in accordance with the equipment manufacturer's tabulated data, or a registered professional engineer.
 - Sloping or Benching. In Type C soils (what is most typically encountered) the excavation must extend horizontally 1 ½ feet for every foot of trench depth on both sides, 1 foot for Type B soils, and ¾ foot for Type A soils.
 - A registered professional engineer must design protective systems for all excavations greater than 20' in depth.
- **Ladders** must be used in trenches deeper than 4'.
 - Ladders must be inside the trench with workers at all times, and located within 25' of unobstructed lateral travel for every worker in the trench.
 - Ladders must extend 3' above the top of the trench so workers can safely get onto and off of the ladder.
- **Inspections** of every trench worksite are required:
 - Prior to the start of each shift, and again when there is a change in conditions such as a rainstorm.
 - Inspections must be conducted by the competent person (see below).
- **Competent Person(s) is:**
 - Capable (i.e., trained and knowledgeable) in identifying existing and predictable hazards in the trench, and other working conditions which may pose a hazard to workers, and
 - Authorized by management to take necessary corrective action to eliminate the hazards. Employees must be removed from hazardous areas until the hazard has been corrected.
- **Underground Utilities** must be:
 - Identified prior to opening the excavation (e.g., contact Digsafe).
 - Located by safe and acceptable means while excavating.
 - Protected, supported, or removed once exposed.
- **Spoils** must be kept back a minimum of 2' from the edge of the trench.
- **Surface Encumbrances** creating a hazard must be removed or supported to safeguard employees. Keep heavy equipment and heavy material as far back from the edge of the trench as possible.
- **Stability of Adjacent Structures:**
 - Where the stability of adjacent structures is endangered by creation of the trench, they must be underpinned, braced, or otherwise supported.
 - Sidewalks, pavements, etc. shall not be undermined unless a support system or other method of protection is provided.
- **Protection from water accumulation hazards:**
 - It is not allowable for employees to work in trenches with accumulated water. If water control such as pumping is used to prevent water accumulation, this must be monitored by the competent person.
 - If the trench interrupts natural drainage of surface water, ditches, dikes or other means must be used to prevent this water from entering the excavation.
- **Additional Requirements:**
 - For mobile equipment operated near the edge of the trench, a warning system such as barricades or stop logs must be used.

- Employees are not permitted to work underneath loads. Operators may not remain in vehicles being loaded unless vehicles are equipped with adequate protection as per 1926.601(b)(6).
- Employees must wear high-visibility clothing in traffic work zones.
- Air monitoring must be conducted in trenches deeper than 4' if the potential for a hazardous atmosphere exists. If a hazardous atmosphere is found to exist (e.g., $O_2 < 19.5\%$ or $> 23.5\%$, 20% LEL, specific chemical hazard), adequate protections shall be taken such as ventilation of the space.
- Walkways are required where employees must cross over the trench. Walkways with guardrails must be provided for crossing over trenches $> 6'$ deep.
- Employees must be protected from loose rock or soil through protections such as scaling or protective barricades.

END OF SECTION

LOCATION OF WORK

Various locations throughout the City of Newton, including:

- Langley Road Municipal Parking Lot
- Hartford Street Municipal Parking Lot
- Cherry Street / Elm Street Municipal Parking Lot
- Richardson Street Municipal Parking Lot
- Washington Street, between Walnut St and Central Avenue

The exact limits of work shall be reviewed and delineated with the Engineer in the field prior to the Contractor beginning work. The Contractor is responsible for taking accurate measurements of actual field conditions prior to ordering proposed materials or beginning construction.

ITEM SHEETS

The Contractor shall insert prices for each item in ink, in both words and figures, and is to show a total bid price. In the event a discrepancy between the written words and figures, the written words shall govern. In the event an error in the bidders total bid price, the corrected total bid obtained by the summation of the products of the unit prices multiplied by the respective quantities shall stand as the bidder's total bid price.

The Contractor is required to review any related plans, conduct a full site review, and read all the provisions in the document before inserting prices, and is further advised to make his own determination as to the accuracy of the estimated quantities before inserting bid prices.

The estimated quantities shown here are based solely upon a reasonable assessment of the project parameters, thus the Contractor is advised that the actual quantities may vary substantially as field conditions may necessitate. Regardless of the amount of the actual quantities, the unit price(s) shall be that set forth in the Bidder's Item Sheets.

ITEM DESCRIPTION & BID PRICE	ESTIMATED QUANTITY	UNIT	TOTAL COST
ITEM: 697.1 – SILT SACK THE SUM OF: _____ DOLLARS AND _____ CENTS (\$ _____) PER EACH	2	EA.	\$ _____
ITEM: 707.8– BOLLARD THE SUM OF: _____ DOLLARS AND _____ CENTS (\$ _____) PER EACH	15	EA	\$ _____
ITEM: 748.– MOBILIZATION THE SUM OF: _____ DOLLARS AND _____ CENTS (\$ _____) PER LUMP SUM	1	L.S.	\$ _____
ITEM: 832.– WARNING, REGULATORY AND ROUTE MARKER THE SUM OF: _____ DOLLARS AND _____ CENTS (\$ _____) PER SQUARE FOOT	262	S.F.	\$ _____

<p>ITEM: 847.1– SIGN SUP (N/GUIDE)+RTE MKR W/1 BRKWAY POST ASSEMBLY - STEEL</p> <p>THE SUM OF: _____ DOLLARS AND _____ CENTS (\$ _____) PER EACH</p>	88	EA	\$ _____
<p>ITEM: 852.01– TEMP. TRAFFIC CONTROLS</p> <p>THE SUM OF: _____ DOLLARS AND _____ CENTS (\$ _____) PER LUM SUM</p>	1	LS	\$ _____
<p>ITEM: 874.2.– TRAFFIC SIGNS REMOVE AND RESET</p> <p>THE SUM OF: _____ DOLLARS AND _____ CENTS (\$ _____) PER EACH</p>	15	EA	\$ _____
<p>ITEM: 875.21 – PARKING METER REMOVE AND DISCARDED</p> <p>THE SUM OF: _____ DOLLARS AND _____ CENTS (\$ _____) PER EACH</p>	145	EA	\$ _____
<p>ITEM: 999.01 – MISC. WORK ALLOWANCE</p> <p>THE SUM OF: _____ DOLLARS AND _____ CENTS (\$ _____) PER ALL</p>	1	ALL	\$ _____
<p>ITEM: 999.02 – ALLOWANCE FOR PAYMENT OF TRAFFIC CONTROL OFFICERS</p> <p>THE SUM OF: _____ DOLLARS AND _____ CENTS (\$ _____) PER ALL</p>	1	ALL	\$ _____

TOTAL BID:

The Total Bid for all items on this page must be inserted in Paragraph “C” of the BID FORM.

- The scheduling of this work shall be solely at the discretion of the Engineer.
- The scope of the work is subject to modification as the operations progress. In addition, the day-to-day operational aspects may also be subject to modification as the Engineer shall so direct (i.e. final depth, dates & scheduled periods, length of sidewalks).

END OF SECTION

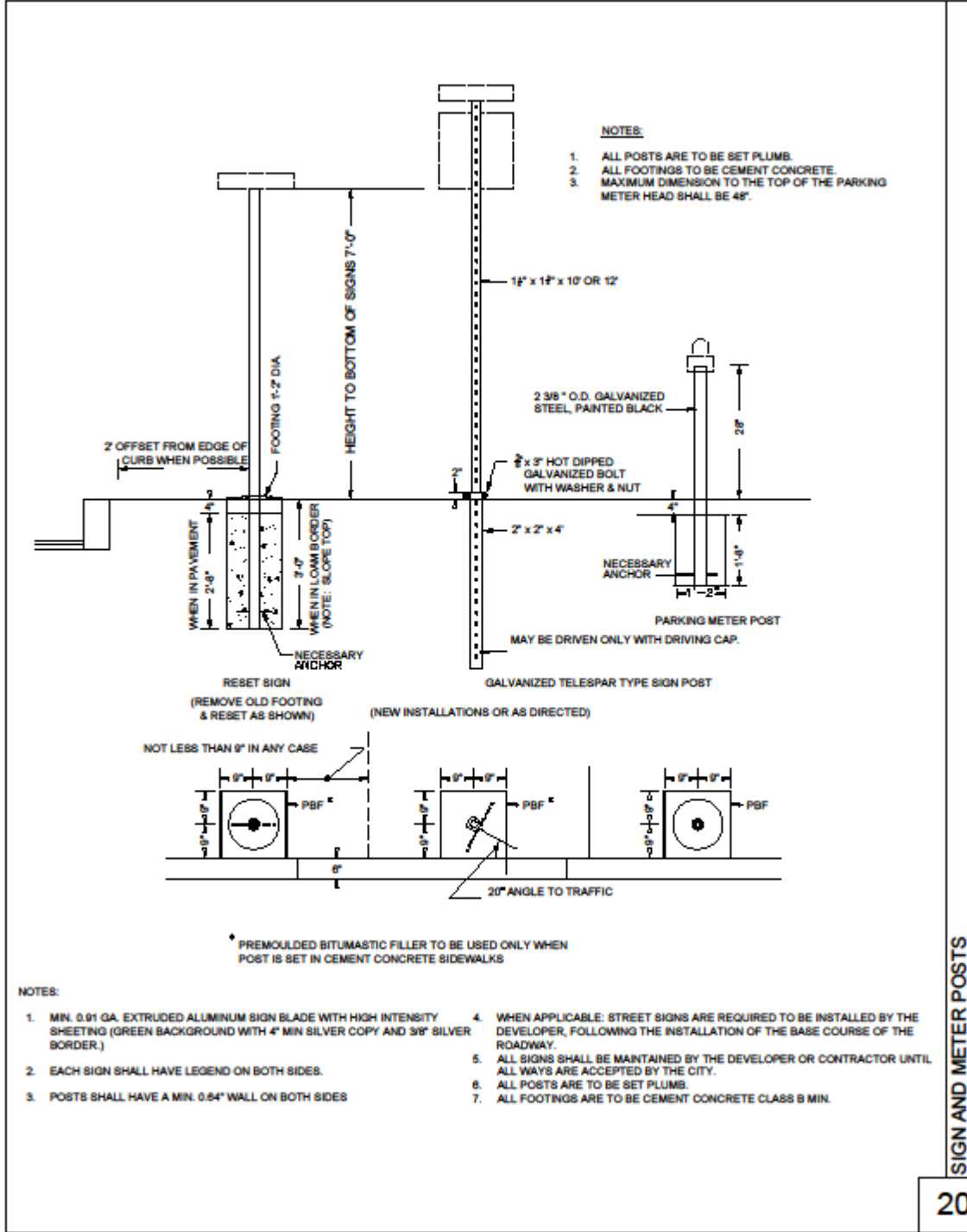

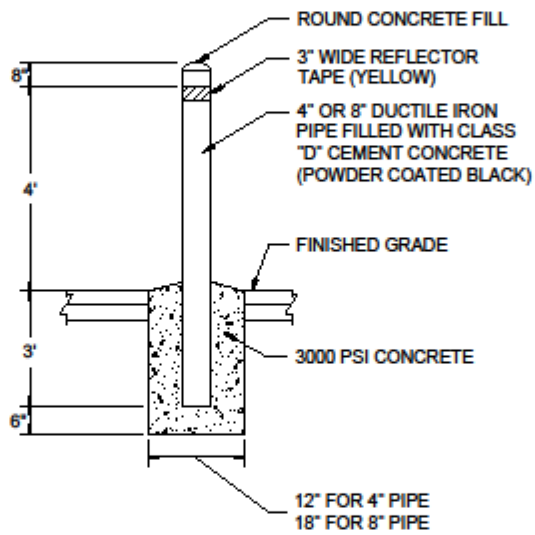

PROPOSED FOUR OR EIGHT INCH (4" OR 8") DIAMETER
 CONCRETE FILLED DUCTILE IRON FIELD FABRICATED
 BOLLARD

NOTE: THE (CUT) EDGES ARE TO BE BEVELED & RENDERED
 SAFE PRIOR TO PLACEMENT OF THE DOME-TOPPED
 CONCRETE FILLER MATERIAL

BOLLARD

20B

CITY OF NEWTON

GENERAL REQUIREMENTS

MEASUREMENT AND PAYMENT

PART 1 GENERAL

1.01 SCOPE

- A. The purpose of this section is to define the basis of measurement and payment for the unit price or lump sum items listed in these Contract Documents.
- B. Section 9.00 of the Commonwealth of Massachusetts Department of Transportation (MassDOT) Standard Specifications for Highways and Bridges 2020 Edition and amendments to it are hereby included in its entirety.

1.02 PAYMENT ITEMS

- A. Work Items of this Project are referenced with Item Numbers and Item Descriptions similar to those currently in use by the MassDOT, Highway Division.

1.03 BASIS OF MEASUREMENT AND PAYMENT

- A. Method of Measurement and Basis of Payment for Work Items shall be as called for under the appropriate section of the MassDOT Standard Specifications, unless modified in this Construction Specifications.

1.04 UNIT PRICES

- A. Payment will be computed on the basis of the unit price bid for each Item and the quantity of units completed. Unit prices are to include cost of all necessary materials, labor, equipment, overhead, profit and other applicable costs for items installed complete and accepted by the Engineer. No Payments will be made for the purchase or stockpile of materials or incidentals to the completed items. (See Par. 1.06, this Section.)
- B. The Owner reserves the right to increase or decrease the scope of the Contract work by 25% of the original scope.

1.05 LUMP SUM PRICES

- A. Payment will be computed on the basis of the percentage of work completed on each item in the contract BID as determined by the Engineer. Lump sum prices are to include the cost of all necessary materials, labor, equipment, overhead, profit and other applicable costs for items installed complete and accepted by the Engineer. No Payments will be made for the purchase or stockpile of materials or incidentals to the completed items. (See Par. 1.06, this Section.)
- B. The Contractor's breakdown of the lump sum bid will be used only as a guide to determine the percentage of completion.

1.06 PRICES INCLUDE

- A. The prices stated in the Proposal include full compensation not only for furnishing all the labor, equipment and material needed for, and for performing the work \ contemplated by, the Contract, but also for assuming all risks of any kind for expenses arising to facilitate the work in a timely manner and all items and incidentals included in the Contract Documents.
- B. The Owner shall pay and the Contractor shall receive the prices stipulated in the BID made a part hereof as full compensation for everything performed and for all risks and obligations undertaken by the Contractor under and as required by the Contract.
- C. The prices for those Items which involve excavation shall include compensation for disposal of surplus excavated material and handling water.
- D. In all Items involving excavation, the price shall be based on doing the entire excavation in earth. Where rock is excavated, the price, therefore, shall be in addition to the cost of excavating earth and no deduction will be made in the amount for earth excavation.

1.07 PAYMENT

- A. In general, payment will be made for all Contract work satisfactorily completed through the end of the previous month. The payment will include any additional work which has been completed and approved and change order work agreed upon by the Owner and Contractor which has been completed and approved.
- B. Each application for payment will indicate the total of a minimum percent retainage, held by the Owner on the total of all work completed under the contract and approved for payment to-date.
- C. Monthly applications for payment may also indicate reduction or increase of the total Contract price when an approved change order results in a net reduction or net increase in the cost and quantity of work to be performed under the Contract.
- D. Special billings and charges against the Contract as credit or payment to the Owner, that are not for change order work, may be subtracted from monies due on any monthly application for payment but shall not serve to reduce the total Contract price.
- E. Final payment for Work governed by unit prices will be made on the basis of the actual measurements and quantities accepted by the Engineer multiplied by the unit price for work which is incorporated in or made necessary by the Work.

FIELD ENGINEERING

PART 1 GENERAL

1.01 SECTION INCLUDES

- A. Survey work and other field engineering responsibilities of the Contractor.

1.03 REQUIREMENTS

- A. The Contractor shall be responsible for field survey, layout of the work, and the establishing of lines and grades for his use.
- B. Establish elevations, lines, levels, reference marks, batter boards, etc., required during the progress of the Work. Verify such marks by instrument to confirm accuracy.
- C. Locate and protect established survey control and reference points.
- D. Make, check, and be responsible for all measurements and dimensions necessary for the proper construction of the Work.
- E. The Engineer will be permitted to check the lines, elevations, reference marks, batter boards, etc., set by the Contractor. The Contractor shall correct any errors found in lines, elevations, reference marks, batter boards, etc. Such a check shall not be construed as approval of the Contractor's work and shall not relieve or diminish the responsibility of the Contractor for the accurate construction and completion of the Work.
- F. Horizontal and vertical control datum for survey shall be as established by the base survey plan, if one is provided, otherwise see G.
- G. Horizontal and vertical control datum for survey shall be as established by contractor.
- H. Locate and protect existing street right of way, bounds and property bounds.
- I. Verify location and reset (if needed) street right-of-way bounds and markers.
- J. The Contractor is to make a video tape and/or photographic record of all existing sideline conditions, prior to the commencement of construction activities, and/or as may be required as the construction activities progress, for the purpose of documenting all decrepit, and/or extraordinary points of concern. All video and picture making shall be done on foot and shall not be 'shot' from a vehicle. This video record shall be made by the Contractor and a copy, or a secondary video tape, shall be delivered to the Engineer. A representative from the Engineering Division shall present at the time of the recording.

1.04 QUALITY ASSURANCE

- A. The Contractor shall employ a Civil Engineer or Land Surveyor registered in the State of Massachusetts, acceptable to the Owner.
- B. The Contractor shall submit a certificate signed by the Contractor's Engineer or Land Surveyor stating elevations and locations of the Work are in conformance with the Contract Documents.

PROJECT MEETINGS

PART 1 GENERAL

1.01 SECTION INCLUDES

- A. Administrative and procedural requirements for project meetings.

1.02 PRECONSTRUCTION CONFERENCE

- A. Pre-bid conference will be held for this project. Attendance at this meeting is optional.
- B. The pre-construction conference will be scheduled and administered within 14 calendar days after the dated "Notice to Proceed." The Contractor shall be prepared to address such topics as understanding of the Contract Documents, Federal/State/Local requirements, projected construction schedules, major personnel, critical work areas, construction facilities and shop drawing/certificates of compliance submittals.

1.03 PROGRESS MEETINGS

- A. The Engineer will schedule and administer progress meetings and specially called meetings throughout the duration of the Work at period intervals. Weekly progress meeting are expected in the initial stages of the project. Meetings can later be scheduled to be Bi-Weekly as determined by the Engineer.
- B. The time and location of such meetings shall be designated by the Engineer and shall be convenient for all parties involved.
- C. The Engineer will prepare agenda with copies for participants, preside at meetings, record minutes, and distribute copies.

SUBMITTALS

PART 1 GENERAL

1.01 SECTION INCLUDES

- A. Requirements for submission of schedules and shop drawings.

1.02 PROGRESS SCHEDULE

- A. Within 14 calendar days after execution of the Contract Documents, the Contractor shall submit to the Engineer for review a construction progress schedule conforming to requirements specified. This schedule should show the proposed dates of commencement and completion of each of the various subdivisions of work required under this Contract and the anticipated monthly percentage of completion, based on the total contract price. The Contractor shall be responsible for updating, and/or revising, this schedule whenever directed by the Engineer throughout the duration of the Contract. The schedule shall also include a Traffic Management Plan to be coordinated with City Engineering and Newton Police Department for each phase and location of work to be constructed under this contract.
- B. Special attention is directed to the requirement that the Contractor shall start the Work, as specified under this Contract, no later than 30 calendar days after the execution of the Contract Documents, unless otherwise authorized by the Owner. The Contractor shall comply with all pre-construction requirements as specified. The Owner reserves the right to delay the commencement of the Work or any part thereof, if the specified requirements as determined by the Engineer have not been satisfied. The Owner further reserves the right to limit or, delay construction, or certain activities thereof, in certain areas of the Contract should the Owner deem it to be in the public's best interest and/or safety to do so.
- C. The Contractor shall contact the appropriate city authorities concerning any public or semi-public events that may occur during the construction period that may affect construction. The Contractor alone shall be responsible for arranging his construction sequence to conform to any restrictions these events may impose. No claims for extras will be allowed because of any delay, extra materials handling, extra excavation, etc. caused by the imposed restrictions. However, additional time may be granted for completion of the work to compensate for delays caused by said restrictions.

1.03 SHOP DRAWINGS

- A. A maximum of two (2) submittals of each shop drawing will be reviewed by the Engineer. If more submittals are required due to the Contractor's neglect or failure to fulfill the requirements of the Contract plans and/or specifications, or to make corrections or modifications required by the Engineer in the review of the first two submittals, the Engineer will review the submittal and the Contractor will be responsible for the cost of the review, as determined by the Owner based on the Engineer's documentation of time and rates for additional services established in the Engineering Agreement between the Owner and the Engineer.
- B. If re-submittals on shop and working drawings are required, the Engineer will retain three (3) copies and three (3) copies will be returned to the Contractor. When re-submittals are returned to the Engineer, six copies of the complete submittal shall again be required.
- C. When so specified or if considered by the Engineer to be acceptable, manufacturer's specifications, catalog data, descriptive matter, illustrations, etc., may be submitted in place of shop and working drawings.
- D. The Contractor shall be responsible for the prompt and timely submittal of all shop and working drawings to eliminate delay to the Work due to the absence of such drawings. All shop and working drawings must be submitted to the Engineer within 30 calendar days prior to incorporation into the Work, unless otherwise permitted by the Engineer. Prior to the submittal of any shop drawings, the Contractor shall submit a schedule of proposed shop drawing transmittals. The schedule shall identify the subject matter of each transmittal, the corresponding specification section number and the proposed date of submission. Prior to and during the progress of the Work the schedule shall be revised and resubmitted as requested by the Engineer.
- E. No material or equipment shall be purchased or fabricated for the Contract until the required shop and working drawings have been submitted as hereinabove provided and reviewed for conformance to the Contract requirements. All such materials and equipment and the work involved in their installation or incorporation into the Work shall then be as shown in and represented by said drawings.
- F. Until the necessary review has been made, the Contractor shall not proceed with any portion of the Work for which review is required.
- G. All shop and working drawings shall be submitted to the Engineer by and/or through the Contractor, who shall be responsible for obtaining shop and working drawings from his subcontractors and returning reviewed drawings to them. All drawings shall be clearly marked with the names of the Owner, Contractor, and building, equipment, or structure to which the drawing applies, and shall be suitably numbered. Submitted shop drawings shall be accompanied by a multi-part letter of transmittal provided by the Engineer, and completed by the Contractor as directed by the Engineer.
- H. Only drawings which have been checked and corrected by the fabricator should be submitted to the Contractor by his subcontractors and vendors. Prior to submitting drawings to the Engineer, the Contractor shall check thoroughly all such drawings to satisfy himself that the subject matter thereof conforms to the Drawings and Specifications in all respects. All drawings which are correct shall be marked with the date, checker's name, and indication of the Contractor's approval, and then shall be submitted to the Engineer; other drawings shall be returned for correction.
- I. If a shop drawing shows any deviation from the Contract requirements, the Contractor shall make specific mention of the deviations in his letter of transmittal.
- J. The review of shop and working drawings by the Engineer will be general only, and nothing contained in this Section shall relieve, diminish or alter in any respect the responsibilities of the Contractor under the Contract Documents and in particular, the specific responsibility of the Contractor for details of design and dimensions necessary for proper fitting and construction of the work as required by the Contract and for achieving the result and performance as specified.
- K. The Contractor shall furnish additional copies of shop drawings or catalog cuts when so requested.

1.04 JOB-MIX FORMULA

- A. Work shall not begin on any Newton project nor shall any mixture be accepted until the Contractor has submitted to the Engineer a specific job-mix formula for the particular uniform combination of materials and sources of supply to be used on each project in conformance with the requirements of Section M3 of MassDOT's Construction Specifications. The job-mix formula shall be submitted in writing by the Contractor to the City at least 30 days prior to the start of paving operations.

QUALITY CONTROL

PART 1 GENERAL

1.01 SECTION INCLUDES

- A. Requirements for Contractor's quality control of products, suppliers, manufacturers, services, site conditions, and workmanship, to produce work of the specified quality.

1.02 QUALITY ASSURANCE/CONTROL OF INSTALLATION

- A. Comply fully with manufacturers' instructions, including each step in sequence.
- B. Should manufacturers' instructions conflict with Contract Documents, request clarification from Engineer before proceeding.
- C. Comply with specified standards as a minimum quality for the Work except when more stringent tolerances, codes, or specified requirements indicate higher standards or more precise workmanship.
- D. Perform work by persons qualified to produce workmanship of specified quality.
- E. Secure Products in place with positive anchorage devices designed and sized to withstand stresses, vibration, physical distortion or disfigurement.

1.03 FIELD SAMPLES

- A. Install field samples at the site as required by individual specifications sections for review.
- B. Acceptable samples represent a quality level for the Work.
- C. Where field sample is specified to be removed, clear area only after field sample has been accepted by the Engineer.

TESTING LABORATORY SERVICES

PART 1 GENERAL

1.01 SECTION INCLUDES

- A. Qualification, duties and responsibilities of testing laboratories. Also, coordination and scheduling are responsibilities of the Contractor.
- B. Related Sections
 - 1. Materials and Equipment

1.02 PAYMENT PROCEDURES

- A. Initial Testing: Unless otherwise specified herein, the Owner will pay for additional initial testing services required by the Engineer.
- B. Retesting: When initial tests indicate noncompliance with the Contract Documents, subsequent retesting occasioned by the noncompliance shall be performed by the same testing agency, and costs thereof will be deducted by the Owner from the Contract Sum.
- C. Contractor's Testing: Inspecting and testing performed exclusively for the Contractor's convenience or as required of him by the technical specifications shall be the sole responsibility of the Contractor.

1.03 REFERENCES

- A. American Society for Testing and Materials (ASTM)
 - 1. E-329-90, Use in the Evaluation of Testing and Inspection Agencies as Used in Construction.

1.04 REQUIREMENTS

- A. Asphalt material will only be accepted by the City if the test results from acceptance samples obtained at the production plant and from the compacted pavement indicate conformance to the approved job-mix formula and the quality limits specified in Section M3 of MassDOT's Construction Specifications.
- B. Work included:
 - 1. Cooperate with the Owner's selected testing agency and all others responsible for testing and inspecting the Work.
 - 2. Provide other testing and inspecting as specified to be furnished by the Contractor in this Section and/or elsewhere in the Contract Documents.
 - 3. Where no testing requirements are described, but the Owner directs testing, the Contractor shall provide testing under the requirements of this Specification.

1.05 QUALITY ASSURANCE

- A. The testing laboratory will be qualified to the Owner's approval in accordance with ASTM E329-90.
- B. Regulatory requirements
 - 1. Testing, when required, will be in accordance with all pertinent codes, regulations, and with selected standards of the American Society for Testing and Materials.
 - 2. Regulatory Requirement Inspections and tests required by codes or ordinances, or by a plan approved authority, and which are made by a legally constituted authority, shall be the responsibility of and shall be paid for by the Contractor, unless otherwise provided in the Contract Documents.

1.06 DELIVERY, STORAGE, AND HANDLING

- A. Comply with pertinent provisions of the Materials and Equipment section.
- B. Promptly process and distribute, to the Engineer, required copies of test reports and instructions to assure necessary retesting and replacement of materials with the least possible delay in progress of the Work.

1.07 SCHEDULING

- A. Establishing schedule
 - 1. By advance discussion with the testing laboratory selected by the Owner, determine the time required for the laboratory to perform its tests and to issue each of its findings.
 - 2. Provide all required time within the construction schedule.
 - 3. Coordinate testing activity with the appropriate testing laboratory.
- B. Revising schedule
 - 1. When changes of construction schedule are necessary during construction, coordinate all such changes with the testing laboratory as required.
- C. Adherence to schedule
 - 1. When the testing laboratory is ready to test according to the established schedule, but is prevented from testing or taking specimens due to incompleteness of the Work, all extra charges for testing attributable to the delay may be back-charged to the Contractor and shall not be borne by the Owner.

PART 3 EXECUTION

3.01 FIELD QUALITY CONTROL

- A. Representatives of the testing laboratory shall have access to the Work at all times and at all locations where the Work is in progress. Provide facilities for such access to enable the laboratory to perform its functions properly.
- B. All specimens and samples for testing, unless otherwise provided in the Contract Documents, shall be taken by the testing personnel. All sampling equipment and personnel will be provided by the testing laboratory. All deliveries of specimens and samples to the testing laboratory will be performed by the testing laboratory.
- C. All work constructed as a deviation from the Contract Documents shall be approved prior by the Engineer in writing. All subject work shall be documented and the submission of required as-builts will be the responsibility of the Contractor.

TEMPORARY CONTROLS

PART 1 GENERAL

1.01 SECTION INCLUDES

- A. Requirements for cleaning, maintenance of the project site, barriers and fences required during construction.

1.02 CLEANING DURING CONSTRUCTION

- A. Contractor shall perform clean-up operations during construction as herein specified, or as specified elsewhere within the Contract Documents.
 - 1. Control accumulation of waste materials and rubbish; promptly dispose of off-site. Bear all costs, including fees resulting from disposal.

2. Maintain project in accordance with all local, State and Federal Regulatory Requirements.
 3. Store volatile wastes in covered metal containers, and remove from premises.
 4. Prevent accumulation of wastes that create hazardous conditions.
 5. Provide adequate ventilation during use of volatile or noxious substances
- B. Conduct cleaning and disposal operations to comply with local ordinances and anti-pollution laws.
1. Do not burn or bury rubbish and waste materials on site.
 2. Do not dispose or volatile wastes such as mineral spirits, oil, or paint thinner in storm or sanitary drains.
 3. Do not dispose of wastes into streams or waterways.
 4. Use only those materials which will not create hazards to health or property and which will not damage surfaces.
 5. Execute cleaning to ensure that the buildings, the sites, and adjacent properties are maintained free from accumulations of waste materials and rubbish and wind-blown debris, resulting from construction operations.
 6. Provide on-site containers for collection of waste materials, debris, and rubbish.
 7. Remove waste materials, debris, and rubbish promptly from the site and dispose of at legal disposal areas off the construction site.
 8. During its progress, the work and the adjacent areas affected thereby shall be kept cleaned up and all rubbish, surplus materials, and unneeded construction equipment shall be removed and all damage repaired so that the public and property owners will be inconvenienced as little as possible.
 9. Where material or debris has washed or flowed into or been placed in existing watercourses, ditches, gutters, drains, pipes, structures, work done under this contract, or elsewhere during the course of the Contractor's operations, such material or debris shall be entirely removed and satisfactorily disposed of during the progress of the work, and the ditches, channels, drains, pipes, structures, and work, etc. shall, upon completion of the work, be left in a clean and neat condition.

1.03 DUST CONTROL

- A. Provide adequate means for the purpose of preventing dust caused by construction operations throughout the period of the construction contract.
- B. This provision does not supersede any specific requirements for methods of construction or applicable general conditions or performance obligations of the Contractor.
- C. Adequate dust control shall be applied as, and when, directed by the Engineer. No additional compensation will be made for such work and shall be considered to be incidental to the Contract.

1.04 EROSION AND SEDIMENT CONTROL

- A. Plan and execute construction by methods to control surface drainage from cuts and fills, from borrow and waste disposal areas. Prevent erosion and sedimentation.
- B. Minimize amount of bare soil exposed at one time.
- C. Provide temporary measures such as berms, dikes, and drains, to prevent water flow.
- D. Periodically inspect earthwork to detect evidence of erosion and sedimentation; promptly apply corrective measures.
- E. Construct sediment control devices for discharge from dewatering trenches.
- F. Construct all sedimentation control devices shown on the plans.

1.05 NOISE CONTROL

- A. Develop and maintain a noise-abatement program and enforce strict discipline over all personnel to keep noise to a minimum.
- B. Execute construction work by methods and by use of equipment which will reduce excess noise.
 1. Equip air compressors with Silencers, and power equipment with mufflers.
 2. Manage vehicular traffic and scheduling to reduce noise.

1.06 POLLUTION CONTROL

- A. Special care shall be taken to prevent contamination or muddying up or interfering in any way with the stream flows, if any along the line of work. No waste matter of any kind will be allowed to discharge into the stream flows or impounded water of any pools or other bodies of water.

1.07 SURFACE WATER CONTROL

- A. Take all precautions to prevent damage to the work or equipment by high waters or by storms. The Engineer with the approval of the Owner may prohibit the carrying out of any work at any time when in his judgment, high water or storm conditions are unfavorable or not suitable, or at any time, regardless of the weather, when proper precautions are not being taken to safeguard previously constructed work or work in progress.
- B. In case of damage caused by the failure of the Contractor to take adequate precautions, the Contractor shall repair or replace equipment damaged and shall make such repairs or rebuild such parts of the damaged work, as the Engineer may require, at no additional expense to the Owner.

1.08 BARRIERS AND ENCLOSURES

- A. Fences and Barricades
 - 1. Provide and maintain temporary fences, barriers, lights, guardrails, and barricades as indicated in the Contract Documents, or as necessary to secure the Work and adjacent property, and protect persons and property.
 - 2. Obtain necessary approvals and permits and provide temporary expedients as necessary to accommodate tasks requiring items mentioned herein.
- B. Protection of Trees
 - 1. The Contractor shall notify the Tree Warden before commencing work within the drip line of any Tree.
 - 2. If, in the opinion of the Engineer or Tree Warden, and so directed by either, the Contractor shall be required to provide adequate and satisfactory tree protection (either trunk protection or drip line protection, or both) as directed. No additional compensation will be made for such protection and shall be considered to be incidental to the Contract.
 - 3. The Contractor shall take care not to harm trees along the sides of roads or within the existing facility in which the construction work is to be done or trees on adjacent lands except as indicated on the drawings or with the written permission of the Owner and any other owner of the trees involved. Care shall be taken not to cut tree roots so as to harm the growth of trees to remain.
 - 4. If, in the opinion of the Engineer or Tree Warden, any trees damaged during construction can be repaired, the Contractor shall satisfactorily repair same at no further cost to the Owner.
 - 5. If, in the opinion of the Engineer or Tree Warden, any tree damaged during construction cannot be repaired and should be removed, the Contractor shall satisfactorily remove and replace, with a species specified by and at the direction of the City Tree Warden, same at no further cost to the Owner.

TRAFFIC REGULATIONS

PART 1 GENERAL

1.01 SECTION INCLUDES

- A. Requirements for traffic control for the duration of the Contract.

1.02 REFERENCES

- A. Manual of Uniform Traffic Control Devices (MUTCD) latest edition, including published revisions; Specifications for Temporary Traffic Control.

1.03 PERFORMANCE REQUIREMENTS

- A. The Contractor shall prepare and submit to the Engineer a proposed work schedule which complies with the plans and specifications. No work shall start until the Engineer's approval of the schedule is received.
- B. The Contractor shall have the sole responsibility for the maintenance and protection of traffic.
- C. No construction will be permitted within 300 feet of a school, day care center, or day camp when children are either arriving or departing the facility. The actual hours involved will be obtained by the Contractor from the respective facility.
- D. An authorized representative of the Contractor shall be available on a 24-hour basis for the duration of the Contract for the purpose of correcting construction related impediments or hazards. This contact shall be responsible for making correction within a timely manner. The contact information shall be supplied with the rest of the required submittals.

1.04 SITE CONDITIONS

- A. Replace at no cost to the Owner pavement markings, legends and lane arrows removed or damaged by the construction operation that are not within the limits of work.
- B. Restore temporary detours to original condition.
- C. Replace traffic signal loops damaged during construction **within 72 hours**.

1.05 SCHEDULING

- A. The Contractor shall minimize the construction impacts to the traveling public and abutting property owners by limiting the extent of roadway excavation and requiring the restoration of a weather-tight pavement surface as stipulated below. All proposed underground installations (utilities, drainage, sewer, etc.) must be in place prior to the beginning of roadway excavation.
- B. The Owner reserves the right to alter the lengths of excavation and other operations in order to ensure the safety of the traveling public and abutting property owners.

PART 2 PRODUCTS

2.01 TRAFFIC CONTROL DEVICES

- A. All Traffic Control Devices shall be in accordance with the MUTCD and maintained as such. All Devices shall also meet and be maintained in compliance with the Specifications,

PART 3 EXECUTION

3.01 INSTALLATION OF TRAFFIC CONTROL DEVICES

- A. Installations shall be in accordance with all requirements and standards as specified in the Manual on Uniform Traffic Control Devices (MUTCD) and shall be the responsibility of the Contractor to install and maintain as directed by the Engineer.

MATERIALS AND EQUIPMENT

PART 1 GENERAL

1.01 SECTION INCLUDES

- A. Requirements for delivery, storage, handling and installation of systems, materials, manufactured units, equipment, components, and accessories used in the work.

1.02 DELIVERY

- A. Refer to Specifications' Sections for requirements pertaining to delivery and handling of materials and equipment.
- B. Transport products by methods to avoid product damage; deliver in undamaged condition in manufacturers' unopened containers or packaging, dry.
- C. Provide equipment and personnel to handle products by methods to prevent soiling or damage.
- D. Promptly inspect shipments to assure that products comply with requirements, that quantities are correct, and products are undamaged.

1.03 STORAGE AND PROTECTION

- A. Refer to Specifications' Sections for requirements pertaining to storage and protection of materials and equipment.
- B. Store products in accordance with manufacturers' instruction, with seals and labels intact and legible. Store sensitive products in weather tight enclosures; maintain within temperature and humidity ranges required by manufacturers' instructions.
- C. For exterior storage of fabricated products, place on sloped supports above ground. Cover products subject to deterioration with impervious sheet covering; provide ventilation to avoid condensation.
- D. Store loose granular materials on solid surfaces in a well-drained area; prevent mixing with foreign matter. Loose material shall also be protected in accordance with Erosion Control specifications.
- E. Arrange storage to provide access for inspection. Periodically inspect to assure that products are undamaged,

and are maintained under required conditions.

- F. Materials stored and location of storage shall be approved by the Engineer prior to delivery.

1.04 INSTALLATION STANDARDS

- A. Comply with Specifications and referenced standards as minimum requirements.
- B. Components required to be supplied in quantity within a Specification Section shall be the same, and shall be interchangeable.
- C. Do not use materials and equipment removed from existing structures, except as specifically required, or allowed, by the Contract Documents.
- D. Perform work by persons qualified to produce workmanship of specified quality.
- E. Secure products in place with positive anchorage devices designed and sized to withstand stresses, vibration, and racking.
- F. When work is specified to comply with manufacturers' instructions, submit copies as specified in the Submittals section, distribute copies to persons involved, and maintain one set in field office.
- G. Perform work in accordance with details of instructions and specified requirements.

MAINTENANCE

PART 1 GENERAL

1.01 SECTION INCLUDES

- A. Procedures for maintaining work completed under this Contract.

1.02 MAINTENANCE PERIOD

- A. The general maintenance period for all construction or materials under this Contract shall be one (1) year subsequent to the date of the acceptance of the work by the Owner, or as provided by other sections of this Specification.
- B. If the Owner puts any structure or equipment to use prior to acceptance of all work under the Contract, the maintenance period for such structures or equipment shall be calculated from the time use begins.
- C. Contractor agrees to replace the material which does not conform to the Contract requirements, and to repair any damage of material or work without cost to the Owner, to the satisfaction of Engineer, in conformance with Contract Documents provided orders for replacement and/or repairs are received in writing by the Contractor within the one year period.
- D. This Section shall in no way limit the duration of the Contractor's responsibility for the correction of any defect due to workmanship or materials provided by the Contractor which are not in compliance with the Contract Documents.

1.03 ABUSE OF WORK

- A. Contractor is not obligated to perform work of replacement or repair that he may prove is required because of abuse by parties other than the Contractor, after the date the Owner puts to continuous use the work requiring replacements or repair, or after date the Owner has approved the Certificate of Completion.

1.04 EMERGENCY REPAIRS

- A. If the Owner deems necessary, the Owner shall order replacement or repairs be undertaken within 24 hours.
- B. If the Contractor delays or fails to make the ordered replacement or repairs within the time specified, the Owner shall have the right to make such replacements or repairs and the expense shall be deducted from moneys due the Contractor, or moneys of the Contractor retained by the Owner.

END OF SECTION

CITY OF NEWTON

SCOPE OF WORK

The work under this Contract shall consist of furnishing all necessary labor, materials and equipment required to remove parking meter poles, install new signs and sign posts, and install bollards, as directed by the City Engineer. The work shall be performed at multiple municipal locations throughout the City of Newton.

All work done under this contract shall be in conformance with:

- the City of Newton Standard Specifications and General Construction Details,
- the Commonwealth of Massachusetts Department of Transportation Standard Specifications for Highways and Bridges, 2020 Edition, as amended,
- the latest Massachusetts Department of Transportation Construction Standard Details,
- the 2006 Massachusetts Highway Department Project Development and Design Guide dated February 25, 2010,
- the latest edition of the Manual on Uniform Traffic Control Devices (MUTCD) with revisions and Massachusetts Amendments,
- the 1990 Standard Drawings for Signs and Supports,
- the 1968 Standard Drawings for Traffic Signals and Highway Lighting,
- the latest edition of American Standard for Nursery Stock,
- the Contract Project Manual with any Project Addenda.

The General Conditions, Supplementary Conditions and Special Provisions shall take precedence over the General Requirements of Division I of the MassDOT Standard Specifications.

References within the Standard Specifications to MassDOT, the Department, or the Engineer shall, for the purposes of this Contract, be construed to mean the City of Newton or its designated representative.

ARCHITECTURAL ACCESS BOARD & AMERICANS WITH DISABILITIES ACT TOLERANCES AND STANDARDS

The Contractor is hereby notified that they are ultimately responsible for constructing all project elements in strict compliance with the current AAB/ADA rules, regulations, and standards.

All construction elements in this project associated with sidewalks, walkways, wheelchair ramps and curb cuts are controlled by 521CMR - Rules and Regulations of the Architectural Access Board (AAB). The AAB Rules and Regulations specify maximum slopes and minimum dimensions required for construction acceptance. There is no tolerance allowed for slopes greater than the maximum slope or for dimensions less than the minimum dimensions.

Contractors shall establish grade elevations at all wheelchair ramp locations, and shall set transition lengths according to the appropriate table in the Construction Standards (or to the details shown on the plans).

ORDERING OF MATERIALS AND DRAWINGS

The Contractor shall provide the Engineer within 30 days of receipt of the contract, written evidence that:

1. Contractor has ordered the shop drawings for the materials for which shop drawings are required for this contract;
2. Contractor has ordered from a supplier or manufacturer materials necessary to complete the project.

The Contractor shall further provide the Engineer written evidence within 30 days of receipt of the Contract that these orders have been confirmed in writing by the manufacturer with delivery dates appropriate for timely completion of the project. These confirmations of orders will become part of the project records.

Failure to comply with any of the ordering requirements shall nullify a request for an extension of the project completion date.

SHOP DRAWING SUBMITTAL (Supplementing Subsection 5.02)

The following is a list of items and materials that require shop drawing or catalog cut approval:

1. **Gravel Borrow (Type B)**
2. **Silt Sack**
3. **Bollard**

JOINTS (Supplementing Subsection 460.65)

The application of hot poured rubberized asphalt sealer, where required in accordance with Subsection 460.65 of the Supplemental Specifications, shall be considered incidental to the work included under Item 460 and 460.01.

CONCURRENT WORK BY OTHERS WITHIN PROJECT LIMITS (Supplementing Subsection 5.06)

Concurrent work may be in progress in the project areas by the City of Newton or utility companies or others. The Contractor is required to coordinate his activities with all work by others within and adjacent to the project limits.

No additional payments will be allowed for any disruption of work schedule caused by or required to coordinate work in this contract and work to be performed by others.

STEEL PLATES IN CONSTRUCTION ZONES (Supplementing Subsection 7.09)

At the end of each working day trenches in areas of public travel shall be backfilled and covered with steel plates, each edge of such plates shall either be beveled or protected by a slope of two (2) feet horizontally to one (1) inch vertically. Any temporary patching material may be used to construct the ramps. The cost of necessary patching materials, and their maintenance and removal, will be considered incidental to the item involved with no separate payment.

PUBLIC SAFETY AND CONVENIENCE (Supplementing Subsection 7.09 of MassDOT's Standard Specifications)

Vehicular and pedestrian travel on the public way shall be maintained by the Contractor during construction and access to abutting land shall be provided at all times. If so directed, temporary walkways will be provided by the Contractor to ensure safe passage under various weather conditions.

PROPERTY BOUNDS (Supplementing Subsection 7.13)

The Contractor shall exercise due care when working around all property bounds, which are to remain. The Contractor shall verify the location and reset (if needed) any street right-of-way bounds or markers damaged or moved by result from the actions of the Contractor, the bound shall be accurately replaced and/or realigned by the Contractor as required by the Engineer. The Contractor shall employ a Land Surveyor registered in Massachusetts to perform this work. No further compensation will be due the Contractor for the materials and labor required to re-establish a bound disturbed by the Contractor, except as otherwise noted herein.

PROTECTION OF UNDERGROUND FACILITIES

The Contractor's attention is directed to the necessity of making his own investigation in order to assure that no damage to existing structures, drainage lines, traffic signal conduits, etc., will occur. The Contractor shall notify the City of Newton and Mass. DIG SAFE and procure a DIG SAFE number for each location prior to disturbing the existing ground in any way.

DIG SAFE Call Center 1-888-344-7233

The Contractor shall notify the City and Dig Safe 72 hours prior to start of construction.

NOTICE TO OWNERS OF UTILITIES (Supplementing Subsection 7.13)

The Contractor shall give written notice to all public service corporations or officials, owning or having charge of public or privately owned utilities, of his intention to commence operations affecting such utilities one (1) week in advance of the commencement of such operations. The Contractor shall, at the same time, file a copy of such notice with the Engineer. Before commencing work on service connections, the Contractor shall contact the serving utility to ensure that proper construction procedures are followed.

The following are the names and addresses of some of the agencies which may be affected, and must be notified.

Completeness of this list is not guaranteed. The Contractor shall ensure that all affected agencies are notified.

City Contract: Lou Taverna, ltaverna@newtonma.gov (617) 796-1020
City Construction: Frank Nichols fnichols@newtonma.gov (617)-796-1033
Police: Lieutenant Dan Walsh, dwalsh@newtonma.gov, (617) 796-2100
Fire: Fire Prevention line, (617) 796-2210
Fire Alarm & Wires Division: Glenn Manning (617) 796-2256
Deputy Commissioner (Tree Warden) Marc Welch (617) 796-1500

Water/Sewer/Drain: Bob Sullivan, Chris Casto, Livio Cence (617) 796-1640
Gas: National Grid, Tammy Saporitio tammy.saporitio@nationalgrid.com (978)-270-5205
Electric: Eversource, Kim Khounesombat kim.khounesombat@eversource.com
MWRA: Ralph Francesconi, (617) 305-5827
Comcast: Manual Furtado (508) 884-2362
RCN: Joe Volpe (617) 828-6904
Verizon: Stanley Usovicz stanley.j.usovicz@verizon.com

NOTICE TO UNITED STATES POSTAL SERVICE (USPS) POSTMASTER

The Contractor shall give sufficient notice to the USPS Postmaster of his intention to conduct work in an area where a Mail Collection Box, Mail Transfer Box, or the service thereof may be affected by the construction operations. Before commencing work near a Mail Collection Box that will be affected by the construction, the Contractor shall contact the USPS Postmaster responsible for the Mailbox to ensure that proper procedures are followed. The Contractor may not commence work in this area until the unit has been moved by the USPS or its designee.

PROTECTION OF UTILITIES AND PROPERTY (Supplementing Subsection 7.13)

The Contractor, in constructing or installing facilities, alongside or near sanitary sewers, storm drains, water or gas pipes, electric or telephone conduits, poles, sidewalks, walls or other structures, shall, at his expense, sustain them securely in place, cooperating with the officers and agents of the various utility companies and municipal departments which control them, so that the services of these structures shall be maintained. He shall also be responsible for the repair or replacement, at his own expense, of any damage to such structures caused by his acts or neglect, and shall leave them in the same condition as they existed prior to the commencement of work.

In case of damage to utilities, the Contractor shall promptly notify the owner and shall, if requested by the Engineer, furnish laborers to work temporarily under the owner's direction in providing access to the utility. Pipes or other structures damaged by the operation of the Contractor may be repaired by the City or by the utility company which suffers the loss. The cost of such repairs shall be borne by the Contractor, without compensation therefor.

If, as the work progresses, it is found that any of the utility structures are so placed as to render it impracticable, in the judgment of the Engineer, to do the work called for under this Contract, the Contractor shall protect and maintain the services in such utilities and structures and the City will, as soon thereafter as it reasonably can, cause the position of the utilities to be changed or take such other action as it deems suitable and proper.

If live service connections are to be interrupted by excavation of any kind, the Contractor shall not break the service until new services are provided. Abandoned services shall also be plugged off or otherwise made secure by the utility company involved.

Full compensation for furnishing all labor, materials, tools, equipment and incidentals and for doing all the work involved in protecting or repairing property as specified in this section shall be considered as included in the prices paid for the various contract items of work and no additional compensation will be allowed therefor.

The Contractor shall be required to furnish all labor, materials, and equipment necessary to protect underground structures and electrical vaults within the project site from construction debris and water penetration. When underground structures or electrical vault roofs are excavated, the Contractor shall be responsible for maintaining security of these structures or electrical vaults against unauthorized access. The Contractor shall be responsible for leaving the structures and vaults in a state of water tightness equal to that existing at the commencement of the contract.

The Contractor will cooperate fully with all utility companies private or public, and will notify all such companies at least twenty-four hours prior to excavating in the vicinity of any utility. It is understood that the Contractor has considered in his bid the existence of the various utilities and that no additional compensation will be allowed for any delays, inconvenience, or damage sustained by him due to any interference by said utilities.

The Contractor shall pay the serving utility for their services rendered for the connection of the overhead service connections.

DRAINAGE (Supplementing Subsection 7.13)

It shall be the Contractor's responsibility to maintain proper drainage in the areas under construction until the final system is put into use.

All affected existing pipes and structures within the limits of this contract shall be left in a clean and operable condition at the completion of the work. It shall be the responsibility of the Contractor to make certain that new drainage systems carrying run-off from the limit of this project operate efficiently to their points of discharge into existing systems. Debris in pipes and structures, including deposition of hazardous material as a result of the Contractor's operations shall be removed by the Contractor in accordance with state and federal guidelines without compensation.

All the above work shall be included under the relevant drainage item without additional compensation therefor. Any adjustments made to new drainage structures will be included under the contract unit price for the respective structures.

DRAINAGE SYSTEM

It shall be the Contractor's responsibility to maintain a proper drainage system at all times in the areas under construction. Existing drainage shall not be taken out of service without prior written notice to the City. All pipes and structures installed as part of this Contract shall be left in a clean and operable condition at the completion of the work.

Drainage castings in new pavement areas shall be installed at base or binder course grade, as directed by the Engineer, and reset to proposed finish surface grade prior to placement of the pavement surface course.

All existing pipes to be abandoned shall be plugged with brick masonry not less than eight (8) inches in thickness in conformance with the MassDOT Standard Specifications, Section 201.62.

No separate payment will be made for the maintenance of the existing drainage system or for plugging of pipes, but all costs in connection therewith shall be included in the unit prices bid for the various Contract items.

DRAINAGE STRUCTURES

Where new pipe is shown on the drawings to be connected into an existing drainage structure to remain, the existing structure shall be first cleaned to remove all mud, debris and other material. The existing structure wall shall be carefully and neatly cut to provide the minimum size opening required for the insertion of the new pipe. The proposed pipe end shall be set or cut off flush with the inside face of the existing structure wall and the remaining space around the pipe completely filled with cement grout for the full thickness of the structure wall.

Existing shaped inverts shall be reconstructed, as necessary to provide a smooth and uniform flow channel from the new pipe through the existing structure.

No separate payment will be made for the cost of connecting new pipes into existing structures, cleaning and necessary alterations of existing structures, but all such costs shall be taken as included in the unit prices bid for the various pipe items. In addition, no separate cost will be made for existing frame and grate (or cover) to be removed and stacked, but shall be made incidental to the appropriate drainage structure items, whether it be adjusted, change in type, remodeled, abandoned, or proposed.

PROTECTION OF PERSONAL PROPERTY

The Contractor shall exercise due care when working around all personal property and roadside features which are to remain. Trees to remain within work limits shall have tree protection. Any damage resulting from the actions of the Contractor, shall be replaced and/or repaired by the Contractor as directed by the Engineer. No further compensation

will be due the Contractor for the materials and labor required to protect personal property, roadside features to remain or protection for trees.

SAWCUTTING

All edges of excavation made in existing pavements, driveways and sidewalks shall be squared by sawcutting with power-driven tools to provide a neat, clean edge for joining new pavement and sidewalks. Ragged, uneven edges shall not be accepted.

Areas which have been broken or undetermined shall be edged neatly with a minimum disturbance to remaining pavement or sidewalks.

All sawcutting will be considered incidental to the associated bid items. Additional sawcutting may be required to prevent damage to adjacent structures as directed by the Engineer.

Saw-cut surfaces shall be sprayed or painted with a uniform thin coat of RS-1 asphalt emulsion immediately before placement of bituminous concrete material against the surface.

FINE GRADING AND COMPACTION

All areas consisting of existing subbase, newly placed subbase, or any other location where fine grading and compaction is necessary, or directed by the Engineer, prior to the installation of top or finish courses shall be thoroughly fine graded and compacted to provide a neat, clean surface for the installation of new materials.

All fine grading and compaction will be considered incidental to the associated bid items.

WORK SCHEDULE (Supplementing Subsection 8.02)

Work on this project is restricted to 7:00 A.M. to 4:30 P.M. for **Daytime** work (be advised that the City of Newton may restrict work on arterial streets between the hours of 7:00 A.M. to 9:00 A.M. and from 3:30 P.M. to 4:30 P.M. in certain situations as designated by the Engineer), 8:00 P.M. to 5:00 A.M. of the next day for **Nighttime** work, and 7:00 A.M. to 4:30 P.M. for **Weekend** (Saturday and Sunday) work (be advised that the City of Newton may restrict work on arterial streets between the hours of 7:00 A.M. to 9:00 A.M. and from 3:30 P.M. to 4:30 P.M. in certain situations as designated by the Engineer). The Contractor is further advised that the hours of operations are set by law. In addition, no weekend or holiday work will be allowed unless special permission is granted. Any work to be completed as part of Nighttime or Weekend time shall be approved or directed by the Engineer. These stipulations apply to the Prime Contractor and all Subcontractors working on the same shift. The Prime Contractor will have superintendent on site whenever work is being performed. No work shall be done on this contract on Saturdays, Sundays, or Holidays, unless approved by the City in advance. Work will not be allowed the day before or the day after a long weekend, which involves a holiday without prior approval by the City. Exceptions may be taken if so stated in the Contract Documents.

There shall be no work beyond the winter shut down date, unless approved in writing by the Engineer. Workdays shall be continuous to the winter shut down.

SCHEDULE OF OPERATIONS (Supplementing Subsection 8.02)

The Contractor shall construct each phase in order as shown in the limits of work unless otherwise directed or approved by the Engineer. The Contractor may work on more than one phase at a time, coordinated with and approved by the Engineer. It shall be the Engineer's option to alter the phasing of work at any time during the project when a change is deemed to be in the best interest of the public. It should be noted that any costs of delays, incurred by these procedures, or changes in these procedures shall be deemed to be included in the contract prices bid and not cause for additional compensation.

PROVISIONS FOR TRAVEL AND PROSECUTION OF WORK (Supplementing Subsection 8.03)

Before starting any work under this Contract, the Contractor shall submit a Schedule of Operation, as provided in Section 8.02. This work schedule shall include a plan of his construction procedures, detours, and the traffic safety devices he will use during the prosecution of the work as set forth in Section 850.

Any area which the Contractor may require for storage of equipment and materials, or for other purposes necessary in

the performance of the work, shall be secured by the Contractor at his own expense. Materials, including excavation intended for backfill, shall not be stored or stacked on roadway surfaces unless specifically permitted by the Engineer.

In general, the Contractor shall coordinate his work with the work to be done by the public utilities or other agencies, and shall so schedule operations as to cause the least interruption to the normal flow of traffic. The Contractor may be required to temporarily suspend operations, when such are considered by the Engineer to be a hindrance hazard to traffic.

The Contractor shall not proceed with surfacing operations without written approval of the Engineer. The Contractor shall provide for the removal of all material spilled from his trucks on existing pavement or other property over which it is hauled, or otherwise deposited thereon whenever, in the judgment of the Engineer, the accumulation is sufficient to cause the formation of mud or dust, or interfere with drainage or create a traffic hazard.

In case of damage to utilities, the Contractor shall promptly notify the Owner and shall, if requested, furnish manpower under the owner's direction in getting access to the utility. Pipes or other structures damaged by the operation of the Contractor may be repaired by the owner, either the municipality or the utility company. The cost of such repairs shall be borne by the Contractor without compensation.

The Contractor shall determine the exact location of all existing utilities before commencing work. Contractor agrees to be fully responsible for any and all damages which might be occasioned by his failure to exactly locate and preserve any and all underground utilities. The Contractor shall include in his bid a sufficient allowance to cover the cost of any exploratory excavations, which are needed to verify utility locations and to accomplish all of the required work.

The Contractor shall be responsible for maintenance of flow in all water courses, drains, and other pipes in the way of the proposed work or for any conveyance of the flow to a suitable point of discharge in such a manner that there will be no flow upon or hindrance to other work or cause nuisance of any kind.

Roadways under construction shall remain open to local traffic at all times during the period of time required for the completion of the work, except when specifically directed otherwise by the City. At least one lane of traffic in each direction must be maintained at all times on all roads and all existing turning movements must be maintained through construction. Pedestrian and vehicle access to all abutting properties shall be maintained except for very short periods of time for passing of active construction equipment and vehicles working in the immediate adjacent rights-of-way. When it is necessary to deny access to a property, the Owner shall be informed at least 48 hours in advance and alternative provisions made. **An accessible route for pedestrians shall be made available at all times and shall be properly maintained as such. The accessible route shall be equal to the distance of the route provided to able pedestrians.**

Facilities shall be provided by the Contractor for the safe and convenient passage of pedestrians and vehicles through the project. Particular care should be taken to establish and maintain methods and procedures which will not create unnecessary or unusual hazards to public safety. The placement of necessary devices will be for daily work periods and shall be removed after the completion of work operations.

All proposed utility work must be completed before roadway rehabilitation begins on a particular roadway. Roadway excavations must be squared-off at the end of each day and any open trenches shall be backfilled and covered with steel plates. Backfilling and plating shall be considered incidental to the project and not be cause for additional compensation.

The Contractor may begin excavation at either end of the project, but must continue from that end to the completion of the project. During non-working hours, no lateral drop-offs will be permitted within the area of excavation. The excavated areas shall be squared-off and ramped longitudinally at a rate of 12:1 or flatter to meet existing surfaces.

The City reserves the right to alter the lengths of excavation and other operations, for the convenience of the traveling public and abutting property owners.

SAFETY CONTROLS FOR CONSTRUCTION OPERATIONS (Supplementing Subsections 850.21 and 850.61)
Unless otherwise provided for by specific items in this contract, furnishing safety controls for construction operations shall be considered incidental to this contract and the costs for safety controls shall be included in the various price for

those contract items requiring such controls.

Positioning, adjusting and re-positioning of all devices such as traffic cones, drums, barricades, concrete barriers, high level warning devices, etc., not otherwise paid for under other items in this contract, is considered incidental and no separate payment will be made.

Signs having messages that are irrelevant to normal traffic conditions will be removed or properly covered at the end of each work period. Signs are to be kept clean at all times, and legends shall be distinctive and unmarred. The Contractor shall provide, place and erect all necessary barricades and warning signs and maintain adequate lights and illumination therefor. He shall be held responsible for all damage to the work due to any failure of signs and barricades needed to protect the work from traffic, pedestrians, or other causes.

Construction Signing and maintenance of Traffic will be paid for under Item 852.01.

ENVIRONMENTAL CONTROLS

Contractor shall control all dirt, dust erosion and other related construction emissions from the project to the satisfaction of the City. Contractor shall comply with all applicable local, state and federal environmental regulations and permit requirements.

The Contractor shall clean and flush all affected drainage structures at the end of the work to the satisfaction of the engineer. The price associated with this work will be deemed incidental to the contract.

All construction equipment shall be fitted with suitable muffling devices so that the noise from construction operation shall be properly controlled. The Contractor shall control all dirt, dust erosion and other related construction emissions from the project to the satisfaction of the Designated Agent.

Calcium chloride for roadway dust control and/or water for roadway dust control shall be applied in accordance with Section 440 at the direction of the Engineer. All costs in connection with the application of calcium chloride and/or water shall be included in the various payment items and no additional compensation will be made.

EXCAVATION SUPPORT

Where the Work of the project requires installation of excavation support systems, the furnishing, installing, maintaining, and final removal as required shall be considered incidental to the item to which it pertains. Dewatering, when required, including disposal in accordance with State and Federal guidelines shall also be considered incidental.

DISPOSAL OF SURPLUS MATERIALS

All existing and other materials not required or needed for use on the project, and not required to be removed and stacked, shall become the property of the Contractor and shall be removed from the site during the construction period and legally disposed of. No separate payment will be made for this work, but all costs in connection there with shall be included in the prices bid for various contract items.

CLEARING AND GRUBBING

No tree, including trees in clear & grub areas, shall be removed prior to receiving approval of the City of Newton. The removal of all trees shall be coordinated with the City of Newton prior to removal. The clearing and grubbing work shall be considered incidental to the Contract. No separate payment shall be made for clearing and grubbing.

TRAFFIC OFFICERS

Uniformed Traffic Officers will be required during the construction period. It shall be the responsibility of the Contractor to arrange for the necessary police details when approved by the City for each police detail required. This request and approval may be verbal or in writing at the discretion of the City. 48-hour notice to the Police Department is required.

The City will pay the exact charges for police details ordered, with the approval of the Engineer, by the Contractor for this project. There will be no administrative fee, mark-ups, or any other additional costs paid to the Contractor.

If the Contractor fails to cancel any police detail not needed, by the required deadline, as set forth by the Newton Police

Department, the cost for such detail as invoiced to the City shall be deducted from the total reimbursement to the Contractor, unless otherwise waived by the City. There will be no separate payment for the Contractor's coordination with the Police Department or City to obtain police details.

END OF SECTION

Construction Specifications

Description

ITEM 697.1 - SILT SACK

Description

The work under this Item shall conform to the relevant provisions of Section 670 of the Standard Specifications and consist of the furnishing, installing, maintaining, and removing silt sacks from all catch basins, drop inlets, and gutter inlets within the limit of work, or otherwise required.

Materials

Silt sacks shall be made out of woven polypropylene geotextile fabric and sewn by a double needle machine, using a high strength nylon thread. Devices shall be ACF Environmental (800)-448-3636; Reed & Graham, Inc. Geosynthetics (888)-381-0800; The BMP Store (800)-644-9223; or approved equal.

Silt sacks shall be manufactured to fit the opening of the catch basins and all curb openings shall be blocked to prevent stormwater from bypassing the device. Silt sacks shall be manufactured with two dump straps attached at the bottom of the silt sack. Silt sacks shall have a ¼-inch nylon expansion restraint rope with two (2) inch flat washers to keep the sides of the silt sacks away from the catch basin walls. Silt sacks shall be manufactured so that they have a certified average wide width strength per ASTM D-4884 standards of 165.0 lb./in for regular flow.

Construction Method

When the expansion restraint rope is covered with sediment, the silt sack shall be emptied, cleaned, and placed back into the catch basin.

All material removed from the silt sacks shall be properly handled and disposed of by the Contractor, and this must be done in accordance with all DEP regulations, policies, and guidance and at no additional cost to the City. The responsibility for the proper handling and disposal of this material shall be solely the Contractor's.

Material removed from silt sacks shall be transported immediately to the place of disposal in machines or trucks that will not spill the material along the roadway. Any material falling on the roadway shall be removed at the Contractor's own expense.

Silt sack cleanings are classified as a solid waste by the Massachusetts Department of Environmental Protection (DEP) and may be disposed of at any landfill that is permitted by DEP to accept solid waste. Materials containing free-flowing liquids are prohibited from being accepted at landfills. The DEP encourages the beneficial reuse of this material whenever possible; however, use not in accordance with DEP determination, or disposal or use as fill in an unapproved location is not acceptable.

It is anticipated that most, if not all, of the material will be landfilled, therefore the Contractor should be aware that many landfills may require testing and analysis of the material prior to accepting it for disposal at the facility.

The Contractor should be aware that in the event that the test results indicate a hazardous waste that cannot be landfilled, the Contractor shall be responsible for all costs associated with adhering to special regulations regarding disposal of hazardous waste. The Contractor should take this into consideration in preparing the bid.

Silt sacks shall remain in place until the placement of the pavement overlay or top course and the graded areas have become permanently stabilized by vegetative growth. All materials used for the silt sacks will become the property of the Contractor and shall be removed from the site.

The Contractor shall inspect the condition of silt sacks after each rainstorm and during major rain events. Silt sacks shall be cleaned periodically to remove and dispose of accumulated debris as required. Silt sacks, which become damaged during construction operations, shall be repaired or replaced immediately at no additional cost to the City.

When emptying the silt sack, the contractor shall take all due care to prevent sediment from entering the structure. Any silt or other debris found in the drainage system at the end of construction shall be removed at the Contractor's expense. The silt and sediment from the silt sack shall be legally disposed of offsite. Under no condition shall silt and sediment from the insert be deposited on site and used in construction.

When the silt sacks are removed after the work has been completed, the Contractor shall clean and flush all drainage structures as incidental to this item.

Measurement and Payment

Silt sacks will be paid for at the Contract Unit Price bid per each, complete in place, which price shall include all labor, materials, equipment and incidental costs required to complete the work. No separate payment will be made for testing, inspections, maintenance, removal and disposal of the sediment from the insert or for the final removal and disposal of the silt sack, but all costs in connection therewith shall be included in the Contract Unit Price Bid.

ITEM 707.8 - BOLLARD

Description

Work under this Item shall consist of furnishing and installing concrete filled pipe, in accordance with the City of Newton General Construction Details and as specified herein.

Materials

Bollards shall be 4" diameter concrete filled ductile iron field fabricated bollards. The top of the bollards shall be round concrete fill.

Three (3) inch wide yellow reflector tape shall be placed 8" below the top.

Bollards shall be powder coated black and shall conform to the relevant provisions of Subsection 960 of MassDOT's Standards Specifications.

Cement concrete for bollards and footing shall be 3,000 psi and shall conform to Subsection M4.02.00 of MassDOT's Standard Specifications.

Construction Method

All bollards shall be set vertically plumb and securely anchored in cement concrete footings as called for on the construction detail.

The concrete footing shall be placed in such quantity that after being thoroughly consolidated in place the concrete shall be four 3.5' below the finished grade.

Contractor is responsible for securing areas with curing concrete, and shall supply barricades or watchmen, as necessary to prevent damage to newly installed bollards. The Contractor shall be responsible for maintaining new concrete work and shall insure that no defects, markings, or damage by vandals or animals occurs. It shall be the responsibility of the Contractor to replace any damaged portions of the work at their own expense.

The cut edges of the ductile iron tube shall be beveled and rendered safe prior to placement of the dome shaped concrete filled top.

Measurement and Payment

Payment for this Items shall be at the respective Contract Unit Price bid per each bollard, complete in place, to the satisfaction of the Engineer, including but not limited to all saw cutting, excavation, protection, materials, labor, equipment, and all other incidentals necessary to complete the work to the satisfaction of the Engineer.

ITEM 748 – MOBILIZATION

Description

This item shall consist of preparatory work and operations including, but not limited to, those necessary for the movement of personnel, equipment, supplies, and incidentals to the project site, for the establishment of all contractor's field offices, buildings, and other facilities necessary for work on the project and all other work and operations which must be performed or for costs which must be incurred prior to beginning work.

Method of Compliance

(a) The Contractor is to make a video tape and/or photographic record as may be required as the construction activities progress, for the purpose of documenting all decrepit, and/or extraordinary points of concern. All video and picture making shall be done on foot and shall not be 'shot' from a vehicle.

The Contractor is to coordinate and make accommodations for all work performed on private property in the execution of this contract, and is to further coordinate, arrange and/or make accommodations for the performance of all second party utility work which may be required in order to complete the work required under this contract.

The Contractor is responsible for the scheduling and coordination of all Police services under this item, however the actual cost of Police Services will be paid for under the appropriate item in this contract.

Under this item the Contractor will be required to attend informational meetings, typically one for the general public when deemed necessary, and several with the City of Newton administration in order to discuss and subsequently address all points of concern, including but not limited to a Preconstruction Conference and Progress Conference(s) and inspection walk-throughs.

Under this item the Contractor is responsible for processing all the necessary paperwork in the execution of this contract, as well as providing and distributing, on a format pre-approved by the Engineer, informational fliers and/or verbal notifications to abutters and/or other concerned parties, to convey important messages as the project commences and as it progresses and such work shall be undertaken and completed at the direction of the Engineer.

(b) Under this item the Contractor shall comply with all special procedural and/or other site specific directives to ensure a structured and efficient execution of this contract. In addition, and from time to time, the Contractor shall also be required to accommodate and comply with other special requests so that the needs of the general public, abutters, and/or other City of Newton agencies are addressed swiftly and appropriately.

(c) The Contractor is to coordinate with the Engineer in making a video tape and/or photographic record of all existing conditions and/or points of concern prior to the commencement of construction activities, or as otherwise may become necessary as the construction activities commence, for the purpose of documenting all decrepit, and/or extraordinary points of concern or interest. This video record shall be made by the Contractor and a copy, or a secondary video tape, shall be delivered to the Engineer.

As the project commences the Contractor may opt to make a photographic record in lieu of a videotape but only to supplement the preconstruction sideline video survey, and only when a photographic record is deemed necessary and sufficient by the Engineer and/or the Contractor.

Videos and/or photographs are to be taken and delivered to the Engineer in such a manner

that the subject matter can be clearly seen, and in such a timely manner that the collected information is not lost. **The video and/or photographs are to be made on foot via a hand-carried camera.**

The Contractor is to give ample notice prior to performing certain extraordinary construction related activities on private lands (i.e. walls, steps etc.), and/or is to discuss, and/or is to make safe and reasonable accommodation of access, for all private property abutters affected by the scheduled construction activities at hand. Notice of intent to construct or to disturb private property and/or access routes shall be made at least twenty four (24) hours in advance of the scheduled activity and/or as directed by the Engineer. This notification shall be made in writing on a format acceptable to the Engineer, with said notices being posted at the subject address in a location nearest to the regular mail delivery location. The decision to post notices will be at the discretion of the Engineer in the field.

Under this item the Contractor shall comply with all local, state and Federal laws.

(d) Under this item the Contractor shall continually coordinate with the Engineer for the purpose of verifying and/or approving all demolition/excavation/disposal quantities, and/or for having all newly delivered/installed material(s) quantified before, during and/or after their installation. No quantities shall be paid unless verified and/or approved by the Engineer.

Measurement and Payment

The Engineer shall make percentage payments as he deems appropriate during the course of the Work.

Under Item 748 the Contractor will be paid the lump sum price for all labor and materials required to complete these tasks throughout the entire term of the project. Item 1 shall not exceed more than three percent (3%) of the total contract cost. Failure to meet this requirement may result in the rejection of the bid.

ITEM 832. - WARNING, REGULATORY, AND ROUTE MARKER

Description

Work under this item shall conform to the relevant provisions of Subsections 828 and 840 of the MassDOT Standard Specifications, the Manual on Uniform Traffic Control Devices (MUTCD) and the following:

Work under this item shall consist of removing and disposing or staking existing signage and posts, furnishing materials, and the installation of new signs and hardware.

Materials

Sign panels shall be made of Aluminum Type A. All hardware shall be Aluminum. Retro-Reflective sheeting shall be Type IV, or higher. The Contractor shall apply the legend using electrocure films, screen printing, or color printing in keeping with manufacturer's specifications in accordance with warranty information.

Measurement and Payment

Payment for Item 832 shall be at the Contract Unit Price bid per Square Foot, complete in place, which price shall include all labor, materials, equipment and incidental costs required to complete the work, including but not limited to the removal and disposal or staking of the existing signage, the coordination of proposed signage locations, style and size with the Engineer, furnishing materials and the installation of new signs and hardware in accordance with these specifications.

ITEM 847.1 - SIGN SUP (N/GUIDE)+RTE MKR W/1 BRKWAY POST ASSEMBLY – STEEL

Description

Work to be done under this item shall conform to the relevant provisions Section 828 "Traffic Signs" as directed by the DPW Commissioner, and the following:

Materials

Supports for signs shall be 2lb per foot hot dipped galvanized, square steel posts, painted black . The posts shall include a base section cast into the sidewalk or driven into grade and an upper section attached to the base section with 2 galvanized bolts.

Construction Method

The contractor shall replace the existing sign posts as directed, with new square steel posts, painted black. The new posts shall be set in the same location as it was prior to construction and the existing sign shall be reset or as directed the sign shall be replaced with a new sign and the old sign discarded.

Measurement and Payment

The work under this item shall be paid for at the contract unit price for Item 847.1 Sign Sup (N/Guide) + Rte Mkr W/1 Brkway Post Assembly – Steel per Each. Such payment shall be considered full compensation for all labor, equipment and materials needed to install sign supports as specified. The cost of removing and resetting the existing sign on the new post is considered incidental to this item. The cost of new signs to be installed as directed shall be paid for at the contract unit price for Item 832 Warning Regulatory and Route Marker Alum. Panel Type A per Square Foot.

ITEM 852.01 – TEMPORARY TRAFFIC CONTROL

Description

Work under this item shall conform to the applicable requirements of Section 850 of the Standard Specifications, The Manual on Uniform Traffic Control Devices (MUTCD), and/or as directed by the Engineer.

The Contractor shall furnish, erect, maintain, wash, move, adjust, repair, relocate, re-erect, and store all temporary construction signs, sign mountings, portable barricades, traffic cones, delineators, and other warning devices when, where, and as specified.

Construction Method

Temporary Traffic Control devices shall cover all work related to the furnishing, installation, maintenance, and movement of traffic protective devices on the project. The Contractor shall provide a sufficient number of signs and other warning devices as required by the nature of the work as determined by the MUTCD and/or the Engineer. Devices that do not meet or exceed MUTCD standards will not be considered an acceptable means for temporarily controlling traffic.

When, in the opinion of the Engineer, the sign or device shall be so severely damaged as to warrant replacement, the Contractor shall provide a new device that shall be deemed to be included in this item.

The Contractor shall keep all signs, barricades, and other protective devices in proper position, clean, and legible at all times. Care shall be taken so that weeds, shrubbery, construction materials and equipment, and spoil are not allowed to obscure any sign, lights, or barricade. Signs that do not apply to existing conditions shall be removed or adjusted so that the legend is not visible to approaching traffic. All signs and markers shall indicate actual conditions existing and shall

be moved, removed, or changed immediately, as conditions require. When construction is not in progress, all unnecessary signs will be adequately covered.

No work is to be undertaken until the Contractor has established construction signs and/or safety devices around and about the project zone periphery. To that end the Contractor shall not commence operations until he has verified that semi-permanent signs (i.e. 'Road Under Construction') and/or daily signing, (i.e. 'Detour') has been appropriately established. The Contractor shall be responsible for establishing supplemental signage, and/or safety devices, as he deemed necessary in order to further provide for the safety of the pedestrian and the motoring public, as well as for affording the opportunity to move the construction process forward without interruption. Under this clause the Contractor shall work closely with the Engineer in order to coordinate the signing activities in a timely and reasonable manner. Said devices shall conform to the Temporary Traffic Control section of the most recent version of the Manual on Uniform Traffic Control Devices (MUTCD). Further, due to the nature of this work, the Contractor shall be required, from time to time, to erect, move, relocate, repair, and/or to remove at days end, any site sign in order to either expedite his work or to otherwise accommodate the safety and/or delineate the project zone and/or its active or inactive detour status and route line, and this work shall be done either at his discretion and/or at the request of a City of Newton Agent(s) or Officer. Non-compliance with any such request, as herein described, shall be grounds for the City to halt work until such remedial measures have been taken, and any such loss of time by the Contractor shall be at his own expense. Any devices provided which are lost, stolen, destroyed or deemed unacceptable while their use is required on the project shall be replaced without additional compensation.

The lump sum for this item shall include full compensation for all labor, equipment, materials and incidentals needed to complete the following:

1. Fabricating, furnishing, erecting, maintaining, removing and relocating the traffic management devices for the overall project during construction activities, complete-in-place, as directed by the Engineer.
2. Providing additional traffic management devices to provide a clear and visible traffic control through the project area, if required.
3. The Contractor shall be required to reposition the traffic control devices as many times as necessary to ensure the safe passage of vehicular traffic and pedestrians. Supplemental signs and traffic control devices directing traffic around and/or through the work zones shall be supplied as operations require or as directed by the Engineer. Payment for these traffic control measures shall be included, as part of this item and no additional payment will be made.
4. At a minimum, traffic control shall include the following:
 - a. Temporary Traffic Control Signs including detour signs as required.
 - b. Channelizing Devices including drum barricades and/or traffic cones.
 - c. Type III Barricades, as required by the Engineer.
 - d. Temporary Barriers, as required by the Engineer.
 - e. Temporary Pedestrian Bypass, as required by the Engineer.

Other work, whether direct or incidental, associated with the traffic control not specifically identified herein.

Measurement and Payment

Payment under this item shall be by the Contract Unit Price bid per Lump Sum. If, after notice by the City, signage is determined to be inadequate, the City may withhold payment on this item until it is addressed satisfactorily by the Contractor. The prices so-stated constitute full and complete compensation for all labor, materials, and equipment associated with (but not limited to) furnishing, erecting, maintaining, washing, movement, adjustment, repair, relocation, re-erection, storing of all temporary construction signs, sign mountings, portable barricades, traffic cones, delineators, drum barricades, channelizing devices, and all other devices, clean-up, legal disposal of all materials, and all other incidentals required to finish the work, complete and accepted by the Engineer. Any damage shall be the Contractor's responsibility.

ITEM 874.2 – TRAFFIC SIGNS REMOVE AND RESET

Description

Work under this item shall conform to the applicable requirements of Sections 828 & 840 of the MassDOT Standard Specifications and the following:

The Contractor shall carefully remove and reset at new locations all existing signs, attachment hardware and sign support posts not included under other sign items as shown on the drawings and as directed by the Engineer.

Construction Method

Signs, attachment hardware and sign support posts shall be satisfactorily stored and protected until reset in the proposed work.

Signs, attachment hardware and sign support posts lost, damaged or otherwise made unsuitable for reuse while being removed, transported, stored or reset shall be replaced with new materials at no additional cost to the City. New attachment hardware shall be furnished and installed as necessary to replace any missing or unusable existing hardware.

Measurement and Payment

Payment for traffic signs removed and reset shall be made at the Contract unit price bid per each, which price shall include all labor, material, equipment and incidental costs required to complete the work.

Item 875.21 - PARKING METER REMOVED AND DISCARDED

Description

Work to be done under this item shall include the dismantling, removal, and discarding of the existing parking meters from locations indicated on the plans as directed by the Engineer.

The work also includes removal and disposal of the existing supports and foundations.

The Contractor is to notify the City before removing any parking meters. The City is to be responsible to remove the meter head and all monies.

The Contractor's work shall include removing the supports, excavating the existing foundation, the disposal of the concrete and supports, backfilling with compacted gravel of the holes resulting from the excavation, and removal of the supports and the replacement in kind of any surface material disturbed.

The Contractor shall backfill with compacted gravel all holes resulting from the removal of the existing parking meters and their foundations and restore the area to match existing conditions of adjacent areas.

Work under this Item shall conform to the relevant provisions of Sections 150 and 170 of the Standard Specifications and the following:

Gravel Borrow shall conform to Material Specifications M1.03.0 (Type B). Gravel Borrow shall be placed with a maximum lift thickness of six (6) inches. Where required, trenches shall be backfilled with approved granular materials and properly compacted to the minimum density of 90 percent of the maximum density as determined by ASTM D1557 (Modified Proctor). All other gravel areas shall be compacted to the minimum density of 95 percent of the maximum density. Any settlements or other defective work and material shall be promptly repaired or replaced at the Contractor's expense. The density of the compacted fill shall be determined by the ASTM D6938 Nuclear Method or latest ASTM standard.

The shaping, trimming, compacting, and finishing of the surface of the subgrade, the grading and finishing of all unpaved areas, and the preparation of all areas for topsoil, loam, slopes, and sidewalk/roadway paving shall be done in close conformance with the lines, grades and typical cross sections described in the specifications, or as directed by the Engineer. Fine grade and compaction shall be considered incidental to this item.

Measurement and Payment

Payment for removing and discarding parking meters will be at the respective contract unit price bid per each, which price shall include all labor, materials, equipment, fine grading, compaction, necessary testing, and any incidentals necessary to complete the work to the satisfaction of the Engineer.

Price shall include all labor, materials, and equipment necessary to complete the saw-cutting, excavation and disposal of cement concrete, and HMA sidewalks/aprons/ramps, legal disposal of unwanted or surplus material, trimming, fine grading, and compaction of subbase material, not covered by other items of this contract and permits.

Parking meters removed and discarded will be full compensation for dismantling, loading, transporting and discarding of parking meters as designated above, the excavation, backfill, and removal of their supports and foundations, and the disposal of supports.

Item 999.01 – MISCELLANEOUS WORK ALLOWANCE

Description

The intent of this section is not for work or materials typically incidental to other work items performed and/or rendered under this contract, or is for work and/or materials which are otherwise called for under these specifications, and/or for work which is indicated on the plans, but for work and materials which are unique in nature and rendered as a direct request of the Engineer. These items of work shall be completed only when and as directed by the Engineer. The Contractor may not proceed with any work under this section without the written notice of the Engineer to complete the work under the “Miscellaneous Work Allowance”.

The sum to be allowed for the work of this item shall be 3% of the total contract cost. All work under this item shall be paid for by one or more or a combination of the following methods at the City’s discretion:

- a. Unit prices previously bid
- b. An agreed lump sum
- c. The actual cost of:
 1. labor, including foreman;
 2. materials entering permanently into the work;
 3. the ownership or rental cost of construction plant & equipment during the time of use on the extra work;
 4. power and consumable supplies for the operation of power equipment;
 5. insurance;
 6. social security and old age, and unemployment benefits.

To the cost under c. there shall be added a fixed fee to be agreed upon, but **not to exceed fifteen per cent (15%) of the actual cost of the work**. The fee shall be compensation to cover the cost of supervision, overhead, bond, profit and any other general expense.

The City shall retain a cash credit in full or in part, in the event that the final cost of materials and/or equipment is lower than the original cash allowance provided.

To the estimated cost or actual cost under (c) for work performed by subcontractors, there shall be added a fixed fee of ten per cent (10%) as compensation to cover the subcontractor’s cost of supervision, overhead, profit and any other

subcontract general expense, plus ten per cent (10%) as compensation to cover the General Contractor's cost of supervision, overhead, profit, bond, and any other general expenses.

Basis of Payment

Payment for work completed under **Item 999.01** shall be as specified above, in full or in part, as pre-approved by the Engineer.

ITEM 999.02 - ALLOWANCE FOR PAYMENT OF TRAFFIC CONTROL OFFICERS

Description

The Contractor shall include in his bid an allowance for payment of Police traffic officers as approved by the Engineer. This allowance will be used as a basis for comparison of bids only.

Under this item the Contractor shall be responsible for ordering, and for canceling details on a day-to-day basis. In the event the Contractor has ordered police details, and does not give the police department ample advance notice that work has been cancelled for that day due to inclement weather or for any other reason, then the Contractor shall bear the expense of that billed detail.

The Contractor shall completely familiarize himself with the current policies regarding and/or regulating police details. In the event police detail requests cannot be completely filled to cover the Contractor's scheduled work for any particular day then the Contractor shall adjust his work schedule accordingly and shall not hold the City responsible for any loss of time, or for any other financial loss. The City of Newton will however grant an extension of time to the original contract term for each day lost due to insufficient police staffing.

Uniformed Traffic Officers will be required during the construction period and shall be paid for directly by the City. It shall be the responsibility of the Contractor to arrange for the necessary police details when approved by the City for each police detail required. This request and approval may be verbal or in writing at the discretion of the City. **Forty-Eight (48) hour notice to the Police Department is required.**

The City will pay the exact charges for police details ordered, with the approval of the Engineer, by the Contractor for this project. There will be no administration fee, mark-ups, or any other additional costs paid to the Contractor.

If the Contractor fails to cancel any police detail not needed, by the required deadline, as set forth by the Newton Police Department, the cost for such detail as invoiced to the City shall be deducted from the total reimbursement to the Contractor, unless otherwise waived by the City. There will be no separate payment for the Contractor's coordination with the Police Department or City to obtain police details."

Measurement and Payment

Under Item 999.02 the Contractor shall submit paid invoices to the Engineer. The Contractor shall then be reimbursed the full invoice amount for City of Newton Police Department charges and/or, when applicable, for Massachusetts State Police charges, as full reimbursement under the allowance for payment of Police officers.

The original invoice issued by the billing authority must be submitted to the Engineer for payment under this item.

END OF SECTION