

CITY OF NEWTON, MASSACHUSETTS

# GENERAL CONSTRUCTION DETAILS

(CONFORMING TO THE CITY OF NEWTON STANDARD SPECIFICATIONS)

REVISED THROUGH DECEMBER 2021

PREPARED AND ISSUED BY:

DEPARTMENT OF PUBLIC WORKS  
NEWTON ENGINEERING DIVISION  
1000 COMMONWEALTH AVENUE  
NEWTON CENTRE, MA, 02459  
617-796-1020

# STREET DESIGN AND PAVEMENT DETAILS

- 1 TYPICAL CROSS SECTION OF STREETS
- 2 DRIVEWAY, CURB, AND SIDEWALKS INSTALLATION
- 3 SIDEWALK AND CURB SCHEME
- 4 CEMENT CONCRETE CURB CUTS
- 5 "T" INTERSECTION PEDESTRIAN RAMP
- 6 PEDESTRIAN RAMP FOR ONE CONTINUOUS DIRECTION OF PEDESTRIAN TRAVEL
- 7 PEDESTRIAN RAMP ON NARROW SIDEWALK WITH DETECTABLE WARNING PANEL
- 8 PEDESTRIAN RAMP WITH LANDSCAPING STRIP
- 9 PEDESTRIAN RAMPS GREATER THAN 12'-4" SIDEWALK
- 10 PEDESTRIAN RAMPS LESS THAN 12'-4" SIDEWALK
- 11 SIDEWALK THROUGH DRIVEWAYS WITH CURB RETURNS 2' CURB CORNERS
- 13 CURB TRANSITION LENGTH FOR PEDESTRIAN RAMPS
- 14 GRANITE PRODUCTS
- 15 GRANITE EDGESTONE / SLOPE CURB
- 16 CAPE COD BERM
- 17 VERTICAL GRANITE CURB
- 18 SIDEWALK SLAB PROTECTION
- 19 TYPICAL TRENCH REPAIR & PAVEMENT SECTION DETAIL
- 20 SIGN AND METER POSTS
- 20B BOLLARD

# WATER, SEWER, AND DRAINAGE

- 21 GRAVITY SEWER TRENCH DETAIL
- 22 TYPICAL WATER TRENCH DETAIL
- 23 TYPICAL C.D.F. (CONTROL DENSITY FILL) TRENCH SECTION
- 24 PAYMENT LIMITS FOR ROCK EXCAVATION IN TRENCHES
- 25 INVERT AND BASE FOR RETROFIT DRAIN MANHOLES
- 26 MANDATORY REQUIREMENTS MANHOLE AND CATCHBASIN
- 27 STANDARD DRAIN MANHOLE (CONCRETE BLOCK TYPE)
- 28 PRECAST CEMENT CONCRETE DRAIN MANHOLE
- 29 STANDARD CATCH BASIN (CONCRETE BLOCK / NEW CONSTRUCTION)
- 30 PRECAST CATCH BASIN
- 30B GUTTER INLET
- 31 TYPICAL PRECAST CONCRETE CATCH BASIN (GAS TRAP TYPE SHOWN)
- 32 SPECIAL CATCH BASIN TO WATERCOURSE (GAS TRAP TYPE SHOWN)
- 33 STANDARD CATCH BASIN DROP INLET (PIPE TO PIPE)
- 34 DROP INLET (CHUTE AND "D" TYPES)
- 35 CATCH BASIN AND GAS TRAP
- 36 INTERNAL DROP CONNECTION
- 37 TYPICAL UNDERDRAIN
- 38 SINGLE CATCH BASIN FRAME AND GRATE
- 39 DOUBLE CATCH BASIN FRAME AND GRATES
- 40 MANHOLE FRAMES AND COVERS
- 41 TYPICAL PVC SEWER HOUSE CONNECTION
- 42 SHALLOW CUT SEWER MANHOLE
- 43 STANDARD SEWER MANHOLE (EXISTING CONSTRUCTION) DROP CONNECTION
- 44 SPECIALSEWER MANHOLE - DEPTH 10'+ (EXISTING CONSTRUCTION)
- 45 PRECAST CEMENT CONCRETE SEWER MANHOLE & OUTSIDE DROP
- 46 TYPICAL SEWER INVERT TABLE PLAN
- 47 SEWER SERVICE INTERIOR DROP MANHOLE
- 48 SEWER CHIMNEY
- 49 SEWER CHIMNEY (PVC)
- 50 HYDRANT DETAIL
- 51 VALVE CHAMBER FOR PIPE 12" AND UP
- 52 WATER METER PIT
- 53 PRECAST CONCRETE METER PIT
- 54 METER PIT ASSEMBLY WITH BYPASS
- 55 TYPICAL THRUST BLOCK CONFIGURATIONS
- 56 TYPICAL WATER SERVICE CONFIGURATIONS
- 57 8" TO 12" GATE VALVE AND CHAMBER

LAYOUT WIDTH	PAVEMENT WIDTH	CROWN
40'	24'	4"
(NEW SUBDIVISION)	29'	4½"
50'	34'	5"

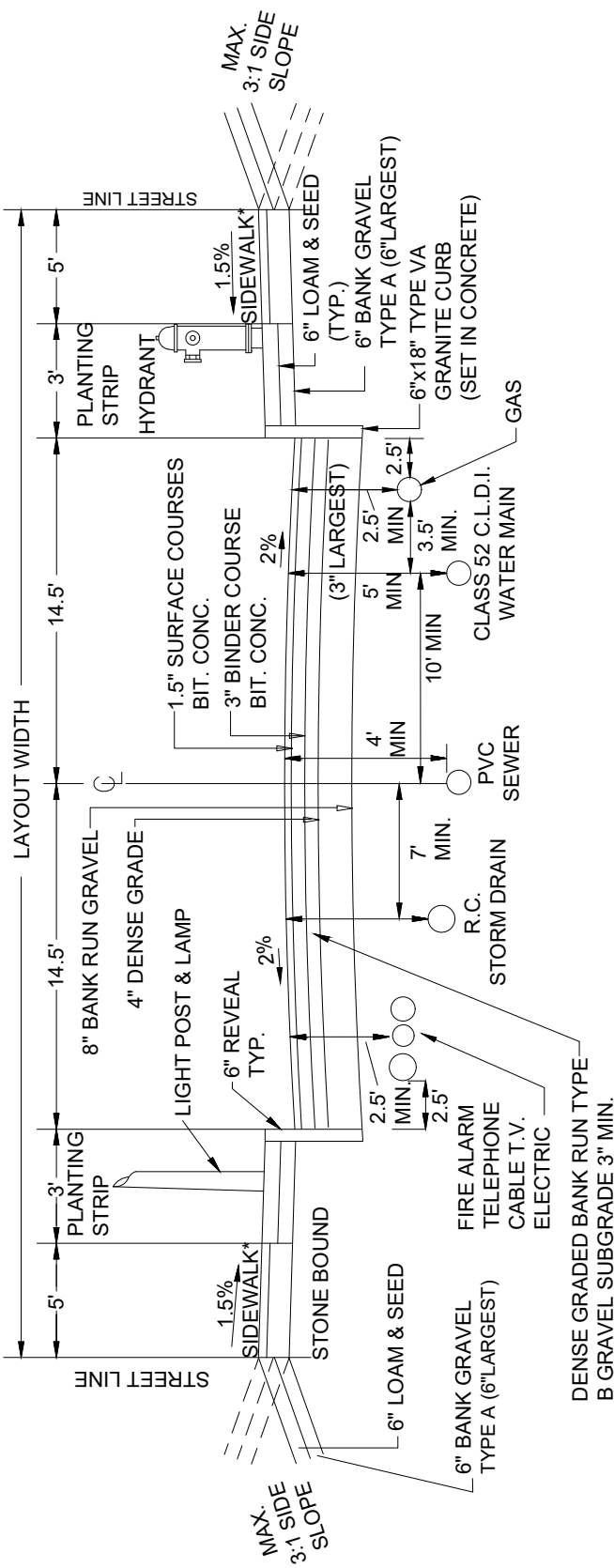

- ALL SOIL IS TO BE COMPACTED TO 95% DENSITY PER A.S.T.M. STANDARDS**
- \*SIDEWALK NOTES:**
- 6" GRAVEL (8" AT DRIVEWAYS) AND 2" DENSE GRADED CRUSHED STONE FOR LEVELING AS DIRECTED (BANK RUN GRAVEL MUST CONFORM TO M1.03.0 OF THE MASSDOT STANDARD SPECIFICATIONS)
  - 4" CEMENT CONCRETE WITH 4000 PSI, ¾" STONE (6" AT DRIVEWAYS, 8" AT PEDESTRIAN RAMPS)
- BITUMINOUS CONCRETE WALKS IN THE PUBLIC WAY ONLY AS DIRECTED**
- 3" BITUMINOUS CONCRETE (1¾" BINDER & 1¼" TOP). SUPERPAVE PAVEMENT.
  - 4" BINDER COURSE REQUIRED IN BUSINESS/INDUSTRIAL SUBDIVISIONS.
  - 6" MINIMUM RECLAMATION MATERIAL ON STREETS WHERE THE EXISTING BIT. ROADWAY IS RECLAIMED

**GENERAL NOTES:** This graphic represents the standards upon which the ENGINEERING DIVISION bases its estimates and driveway feasibility assessments.

No driveway opening will be installed unless the designated 9' x 19' (See Note 2) minimum footprint is clear of any obstructions and is readily accessible.

In those situations where the minimum standards are not clearly met then the applicant must first consult with INSPECTIONAL SERVICES for clarifications of feasibility and possible SPECIAL PERMIT procedures.

Curb cut/street opening permits required for MASSDOT before installation of drive on Needham St. or Rt. 9 and by DCR for Quinobequin Road and Hammond Pond Parkway.

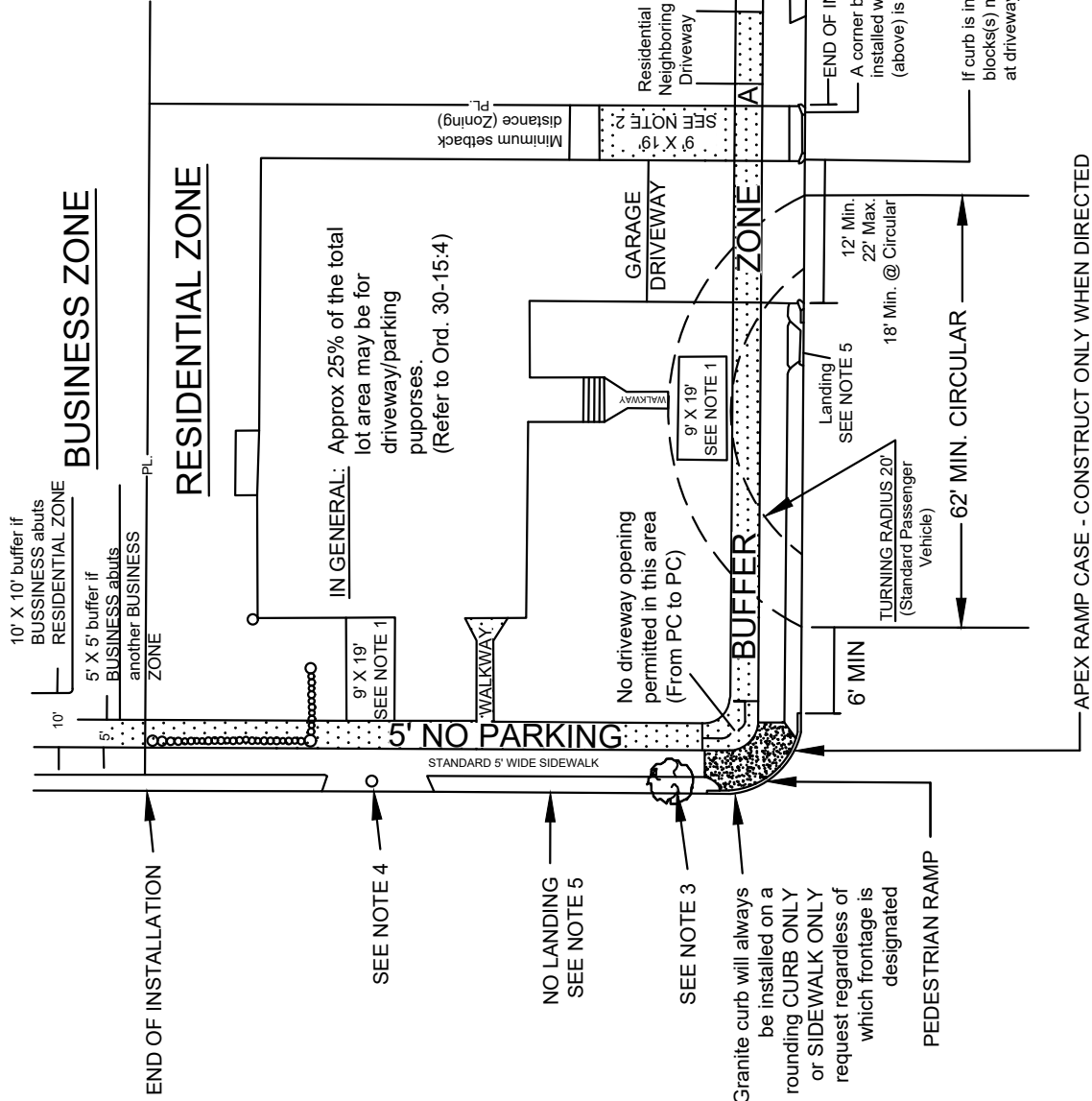

**\*NOTE 1:** CIRCULAR OR STANDARD PULL-IN DRIVEWAY

Compliance with minimum dimensional and/or open space restrictions will allow for a single or double drive opening to be installed.

**\*NOTE 2:** PULL-IN DRIVE (9' X 19') IN A MINIMUM SETBACK ZONE

Compliance with minimum dimensional and/or open space restrictions will allow for a pull-in drive opening when approved by the INSPECTIONAL SERVICES DEPARTMENT.

**\*NOTE 3:** TREE AND/OR STUMP REMOVAL

Tree and/or stump removals must be arranged by the applicant by contracting the City of Newton FOREST DEPT. (No betterment work will be undertaken until the obstruction has been removed.)  
-Ref. to City Tree Ord. #21-72

**\*NOTE 4:** UTILITY RELOCATIONS

Utility relocation (pole, hydrant, sign, etc.) must be arranged by the applicant by contacting the governing UTILITY AGENCY. All costs to relocate any and all utilities will be undertaken until the obstruction has been removed.

**\*NOTE 5:** LANDING

Only one landing per household unless otherwise approved. Granite curb shall always be installed at the face of the landing.

**\*NOTE 6:** 6" Cement concrete shall be used at all driveway aprons.

**\* ORDINANCE REFERENCES:**  
30-1 @ Driveway  
30-15.4 @ Open space  
30-19.9 @ Parking / less than 5 stalls

APEX RAMP CASE - CONSTRUCT ONLY WHEN DIRECTED

## IMPORTANT NOTES:

- REFER TO DETAIL 1 FOR SIDEWALK SECTION.
- CEMENT CONCRETE IS SHOWN. SCHEME APPLIES TO BITUMINOUS CONCRETE ALSO. HOWEVER, ALL JOINTS AND SCORE MARKS ARE ELIMINATED & "TACK" ABUTTING ADJACENT BITUMINOUS CONCRETE PAVEMENTS SHALL BE USED.
- 2" RADIUS CORNER BLOCKS THROUGHOUT UNLESS OTHERWISE SPECIFIED.
- ALL CEMENT CONCRETE IS TO BE BROOM FINISHED.
- ALL DRIVEWAY APRONS TO REMAIN 1" ABOVE ADJACENT GUTTER.
- DEPTH: 4" FOR SIDEWALK, 6" FOR DRIVEWAY APRON, 8" FOR PEDESTRIAN RAMPS
- SEE DETAILS 4 THROUGH 13 FOR PEDESTRIAN CURB RAMPS AND DRIVEWAY APRONS.

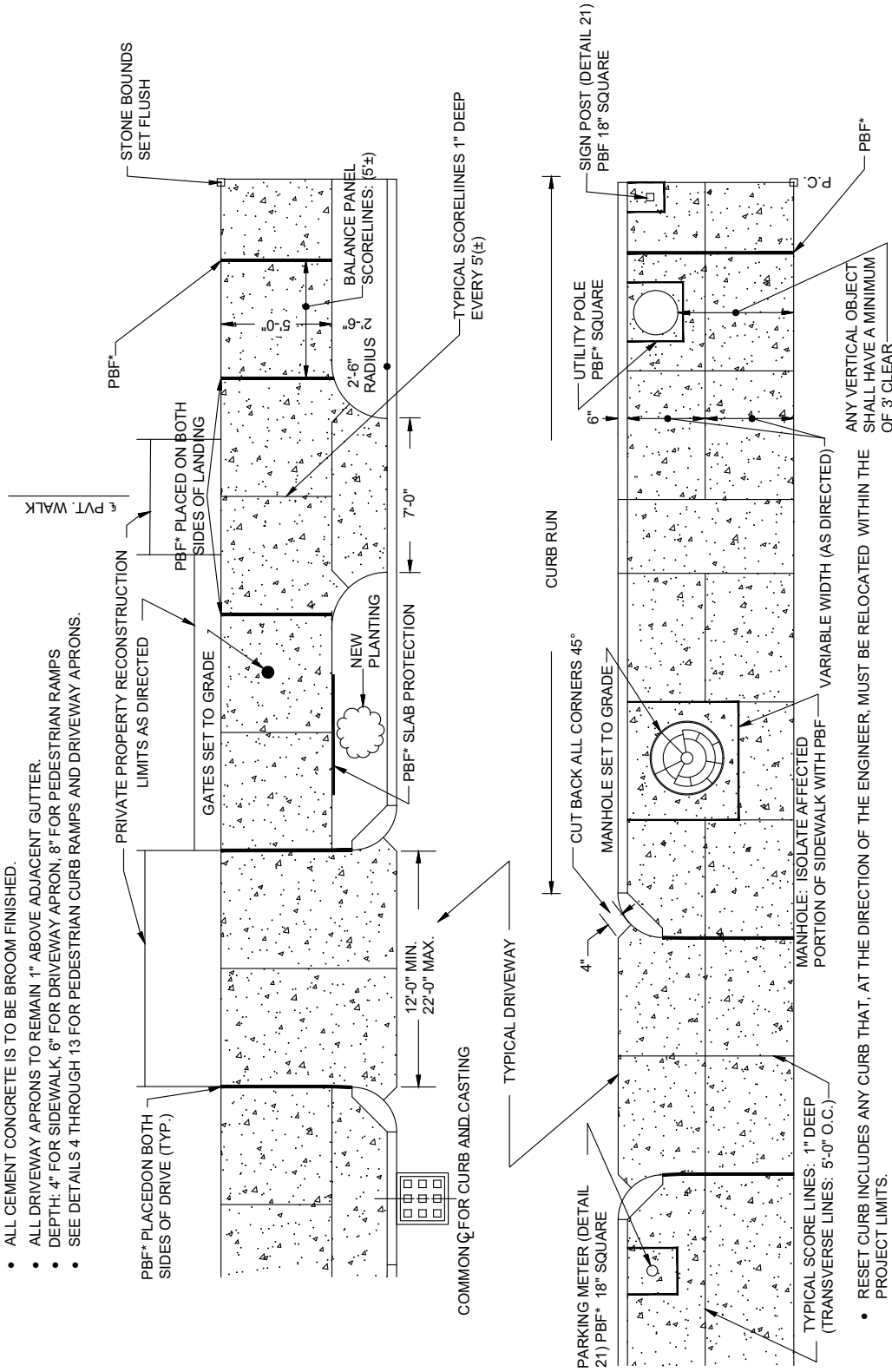

- RESET CURB INCLUDES ANY CURB THAT, AT THE DIRECTION OF THE ENGINEER, MUST BE RELOCATED WITHIN THE PROJECT LIMITS.
- ALL CONCRETE IS TO BE FINISHED FLUSH WITH THE TOP BACK AND ENDS OF ALL CURBING AND CORNER BLOCKS.
- NO MORE THAN TWO PIECES OF CURBING LESS THAN SIX FEET LONG WILL BE ALLOWED TO BE PLACED WITHIN THE SAME "CURB RUN" AND THEY SHALL NOT BE SET SIDE BY SIDE.
- ALL CURB JOINTS SHALL NOT BE GREATER THAN 1/2", SHALL BE POINTED BEFORE THE WEARING COURSE IS PLACED, IF NOT SOONER, AND SHALL BE WIPED CLEAN WITH A CLOTH IMMEDIATELY AFTER POINTING.

\*1/2" T x 4"D PREMOULDED BITUMASTIC FILLER (MAXIMUM SPACING: 30")

\*\*1/2" T x 6"D PREMOULDED BITUMASTIC FILLER (AS APPROVED BY THE CITY ENGINEER)

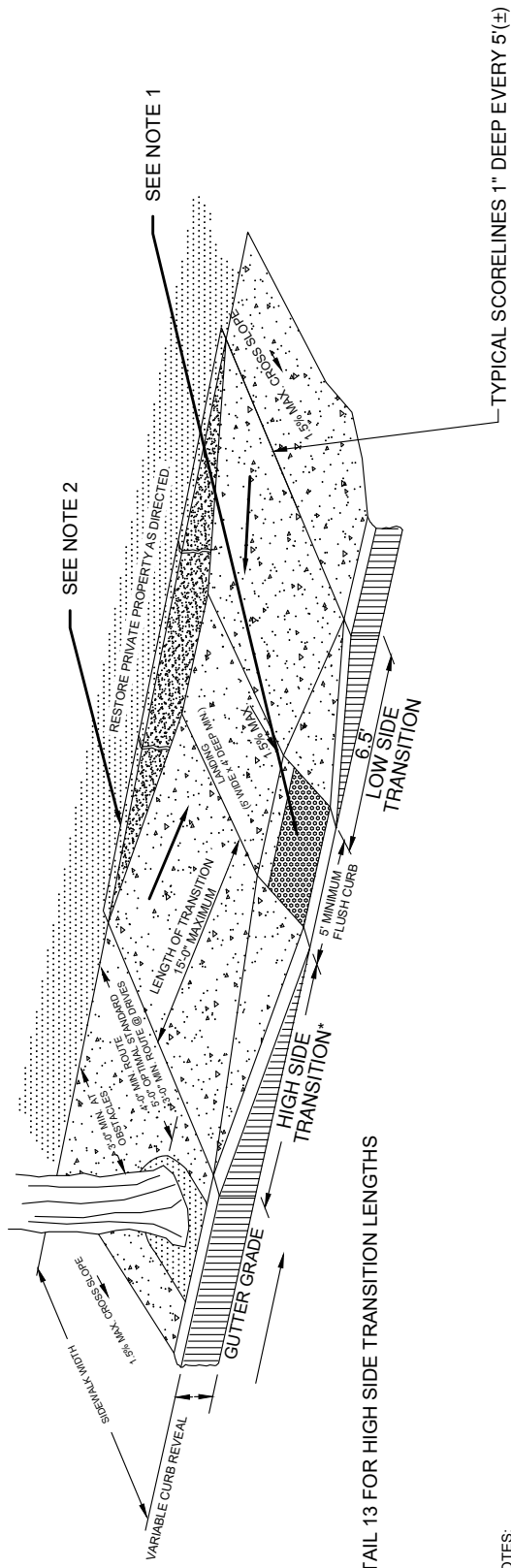

\*SEE DETAIL 13 FOR HIGH SIDE TRANSITION LENGTHS

TYPICAL SCORELINES 1" DEEP EVERY 5(±)

- NOTES:
1. DETECTABLE WARNING PANELS SHALL BE INSTALLED AS DETAILED IN MASSDOT CONSTRUCTION STANDARDS DETAILS E.107.6.5, DATED 2017. THE TILE SHALL CONFORM TO AMERICANS WITH DISABILITIES ACT ADA SOLUTIONS "WET-SET" REPLACEABLE COMPOSITE TACTILE PANELS, 60 INCHES BY 24 INCHES, AND THE COLOR SHALL BE FEDERAL YELLOW.
  2. INSTALL TYPE SC GRANITE EDGESTONE (M9.04.2) AS SHOWN ON THE PLANS OR ONLY AS DIRECTED. EDGESTONE IS TO BE SET VERTICALLY AND IS TO BE CLEANLY BROKEN AND NEATLY FITTED ALONG RADIAL LINES IN 1' INCREMENTS WHERE APPLICABLE. OTHERWISE, NO EDGESTONE LESS THAN 6" IN LENGTH IS TO BE USED ON STRAIGHT RUNS.
  3. SURFACE: 8" CEMENT CONCRETE EMULSIFIED 7% AIR ENTRAINED 4000 PSI, 3/4", 610 (PER MASSDOT STD SPEC M4.02.00)
  4. ALL DIMENSIONAL INFORMATION IS FOR GUIDELINES PURPOSES ONLY. THE FINAL PRODUCTS AND ROUTE CRITERIA SHALL BE PER THE RULES & REGULATIONS OF THE MASSACHUSETTS ARCHITECTURAL ACCESS BOARD AND THE AMERICANS WITH DISABILITIES ACT.

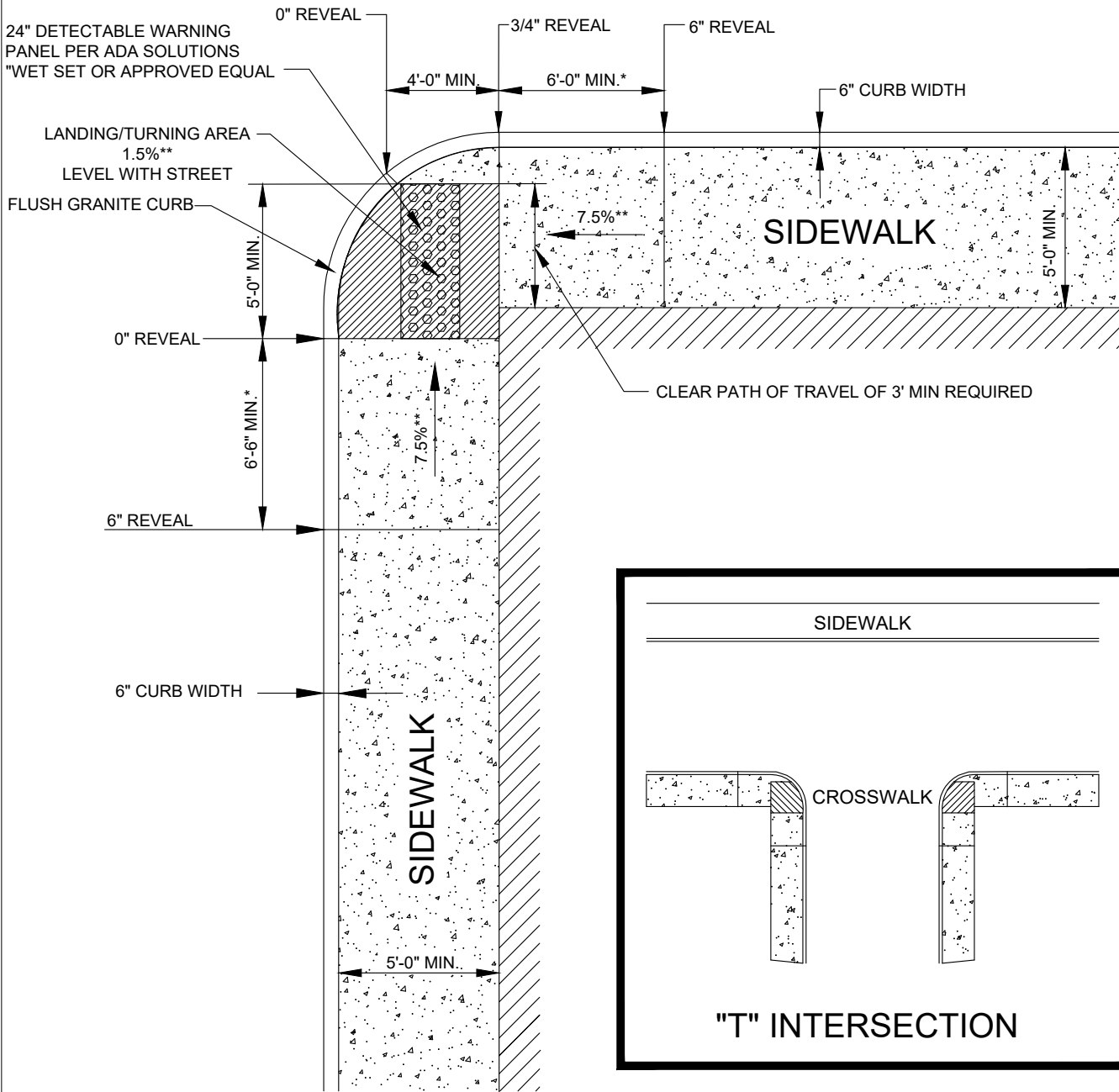

 BUILDING OR OTHER UNALTERABLE CONDITION

\* TRANSITION LENGTH SHOWN IS MINIMUM (SEE DETAIL 13)

\*\* TOLERANCE FOR CONSTRUCTION ± 0.5%

**NOTES:**

ROADWAY, GUTTER, AND FIRST 6" OF SIDEWALK TO BE ADJUSTED FOR FIELD CONDITIONS.

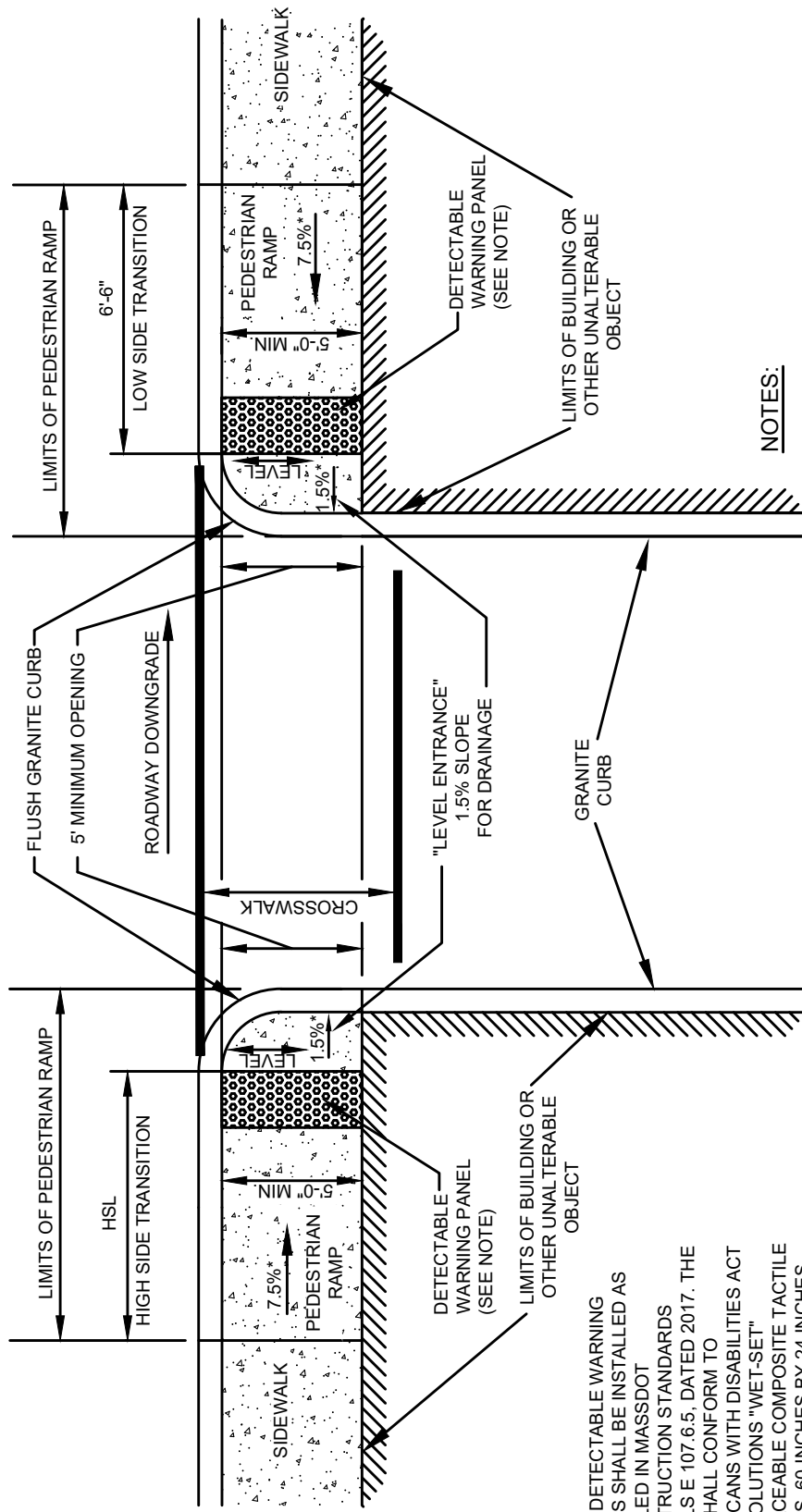

NOTE: DETECTABLE WARNING PANELS SHALL BE INSTALLED AS DETAILED IN MASSDOT CONSTRUCTION STANDARDS DETAILS E 107.6.5, DATED 2017. THE TILE SHALL CONFORM TO AMERICANS WITH DISABILITIES ACT ADA SOLUTIONS "WET-SET" REPLACEABLE COMPOSITE TACTILE PANELS, 60 INCHES BY 24 INCHES, AND THE COLOR SHALL BE FEDERAL YELLOW.

ROADWAY, GUTTER, AND FIRST 6" OF SIDEWALK TO BE ADJUSTED FOR FIELD CONDITIONS.

**LEGEND:**

HSL = HIGH SIDE TRANSITION LENGTH  
(DETAIL 13)

\* = TOLERANCE FOR CONSTRUCTION + 0.5%



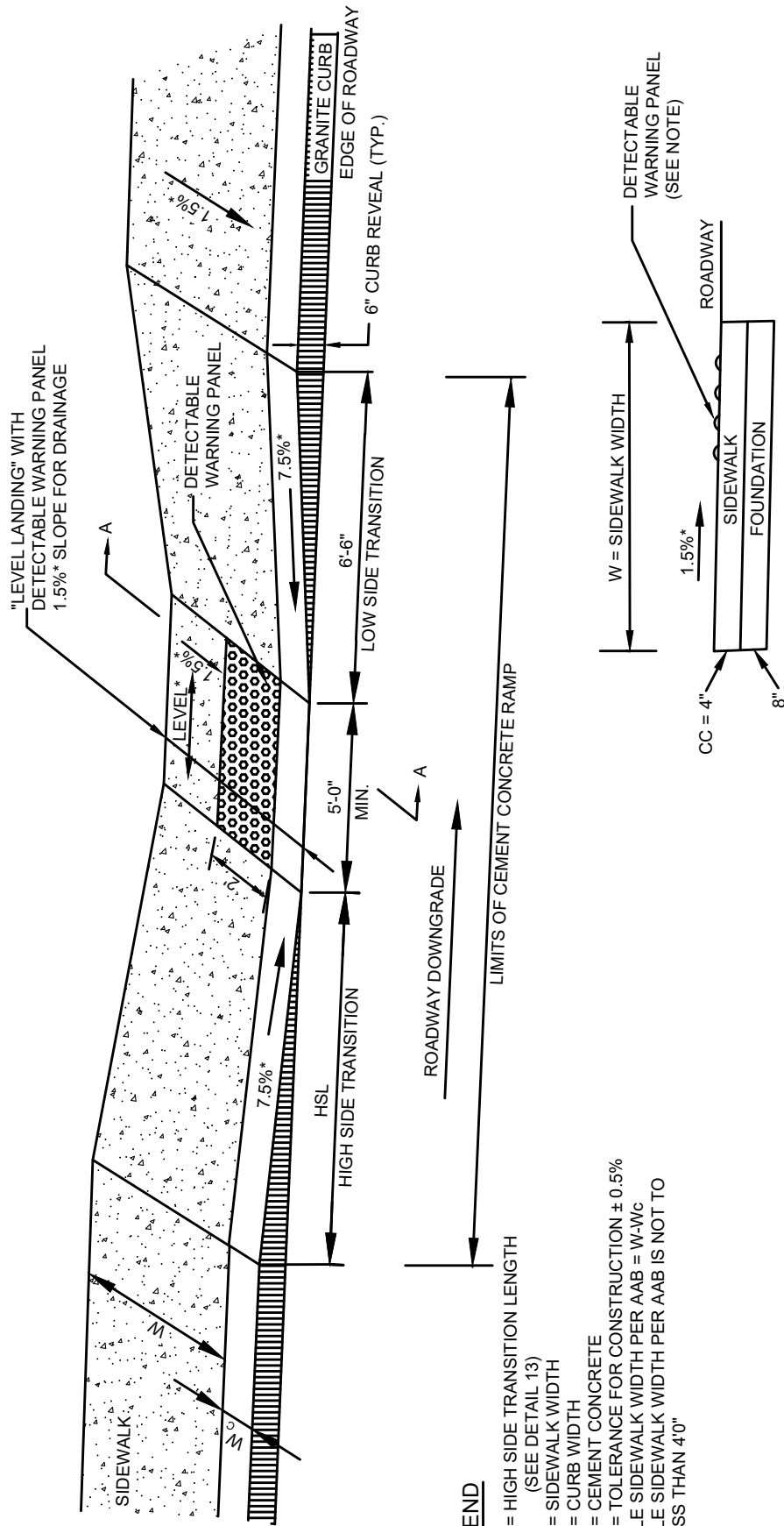

**LEGEND**

- HSL = HIGH SIDE TRANSITION LENGTH (SEE DETAIL 13)
- W = SIDEWALK WIDTH
- W<sub>c</sub> = CURB WIDTH
- CC = CEMENT CONCRETE
- \* = TOLERANCE FOR CONSTRUCTION ± 0.5%
- USABLE SIDEWALK WIDTH PER AAB = W-W<sub>c</sub>
- USABLE SIDEWALK WIDTH PER AAB IS NOT TO BE LESS THAN 4'0"

**NOTE:**  
 DETECTABLE WARNING PANELS SHALL BE INSTALLED AS DETAILED IN MASSDOT CONSTRUCTION STANDARDS DETAILS E 107.6.5, DATED 2017. THE TILE SHALL CONFORM TO AMERICANS WITH DISABILITIES ACT ADA SOLUTIONS "WET-SET" REPLACEABLE COMPOSITE TACTILE PANELS, 60 INCHES BY 24 INCHES, AND THE COLOR SHALL BE FEDERAL YELLOW.

ROADWAY, GUTTER, AND FIRST 6" OF SIDEWALK TO BE ADJUSTED FOR FIELD CONDITIONS

**SECTION A-A**

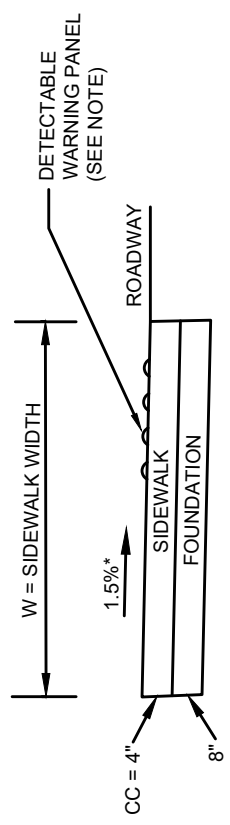

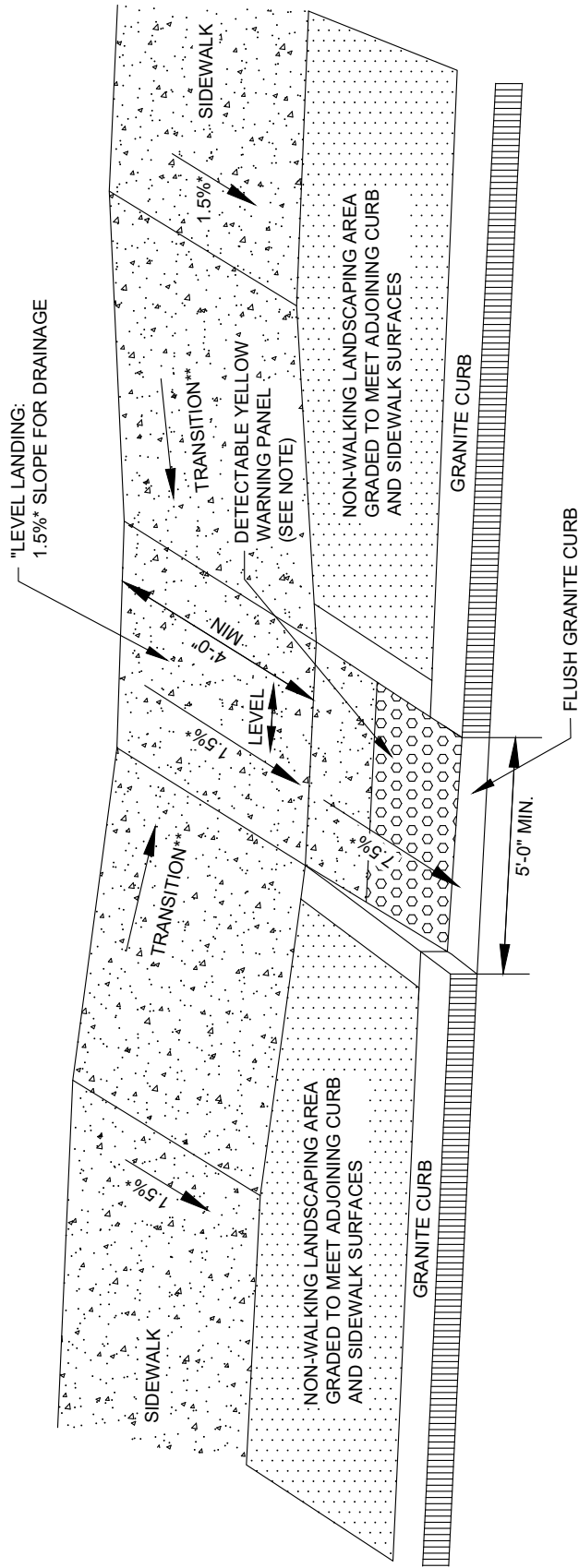

**LEGEND:**

- \* = TOLERANCE FOR CONSTRUCTION + 0.5%
- \*\* = SEE DETAIL 13 FOR TRANSITION LENGTH

**NOTE:**  
 DETECTABLE WARNING PANELS SHALL BE INSTALLED AS DETAILED IN MASSDOT CONSTRUCTION STANDARDS DETAILS E 107.6.5, DATED 2017. THE TILE SHALL CONFORM TO AMERICANS WITH DISABILITIES ACT ADA SOLUTIONS "WET-SET" REPLACEABLE COMPOSITE TACTILE PANELS, 60 INCHES BY 24 INCHES, AND THE COLOR SHALL BE FEDERAL YELLOW.

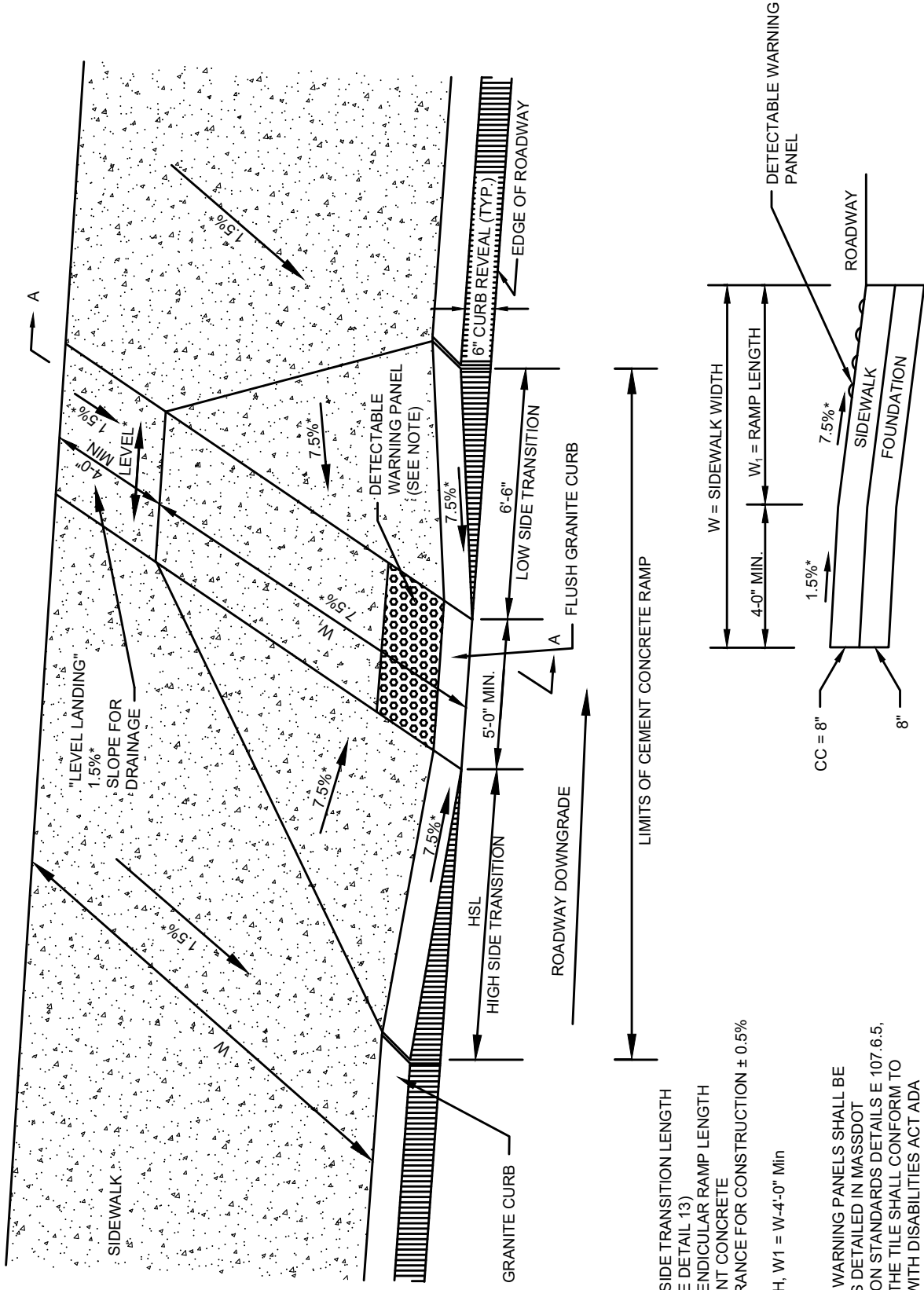

**LEGEND:**

- HSL = HIGH SIDE TRANSITION LENGTH (SEE DETAIL 13)
  - W = PERPENDICULAR RAMP LENGTH
  - CC = CEMENT CONCRETE
  - \*<sub>1</sub> = TOLERANCE FOR CONSTRUCTION ± 0.5%
- RAMP LENGTH,  $W_1 = W - 4'-0"$  Min

**NOTE:**  
 DETECTABLE WARNING PANELS SHALL BE INSTALLED AS DETAILED IN MASSDOT CONSTRUCTION STANDARDS DETAILS E 107.6.5, DATED 2017. THE TILE SHALL CONFORM TO AMERICANS WITH DISABILITIES ACT ADA SOLUTIONS "WET-SET" REPLACEABLE COMPOSITE TACTILE PANELS; 60 INCHES BY 24 INCHES, AND THE COLOR SHALL BE FEDERAL YELLOW.

**SECTION A-A**

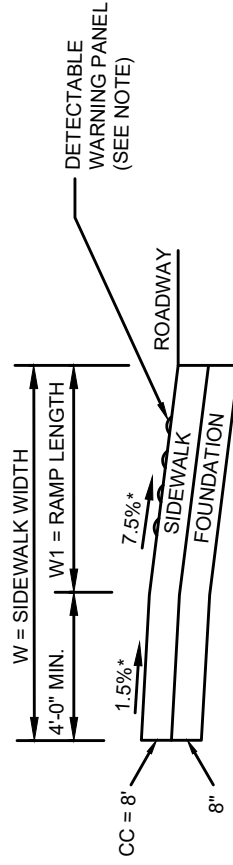
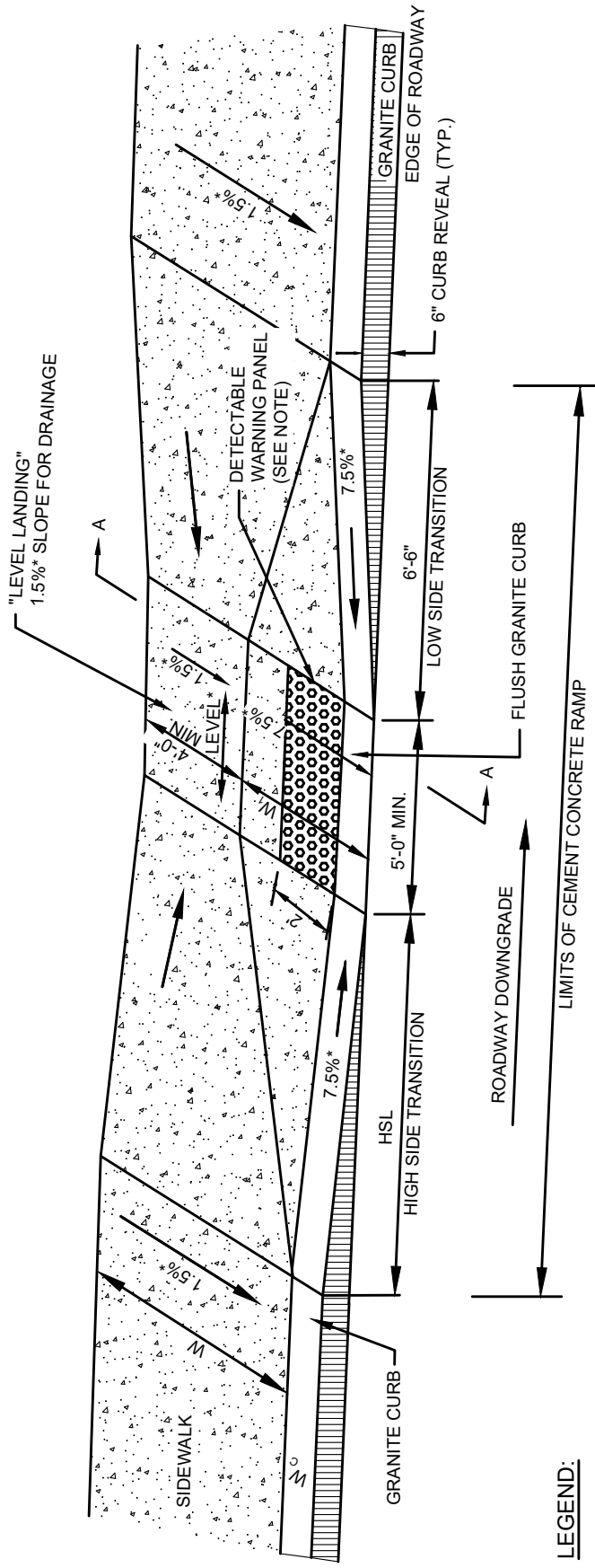

SECTION A-A

**LEGEND:**

HSL = HIGH SIDE TRANSITION LENGTH  
(SEE DETAIL 13)

W<sub>c</sub> = PERPENDICULAR RAMP LENGTH

CC = CEMENT CONCRETE

\* = TOLERANCE FOR

CONSTRUCTION ± 0.5%

RAMP LENGTH, W<sub>1</sub> = W-4'-0" Min

NOTE: DETECTABLE WARNING PANELS SHALL BE INSTALLED AS DETAILED IN MASSDOT CONSTRUCTION STANDARDS DETAILS E 107.6.5, DATED 2017. THE TILE SHALL CONFORM TO AMERICANS WITH DISABILITIES ACT ADA SOLUTIONS "WET-SET" REPLACEABLE COMPOSITE TACTILE PANELS, 60 INCHES BY 24 INCHES, AND THE COLOR SHALL BE FEDERAL YELLOW.

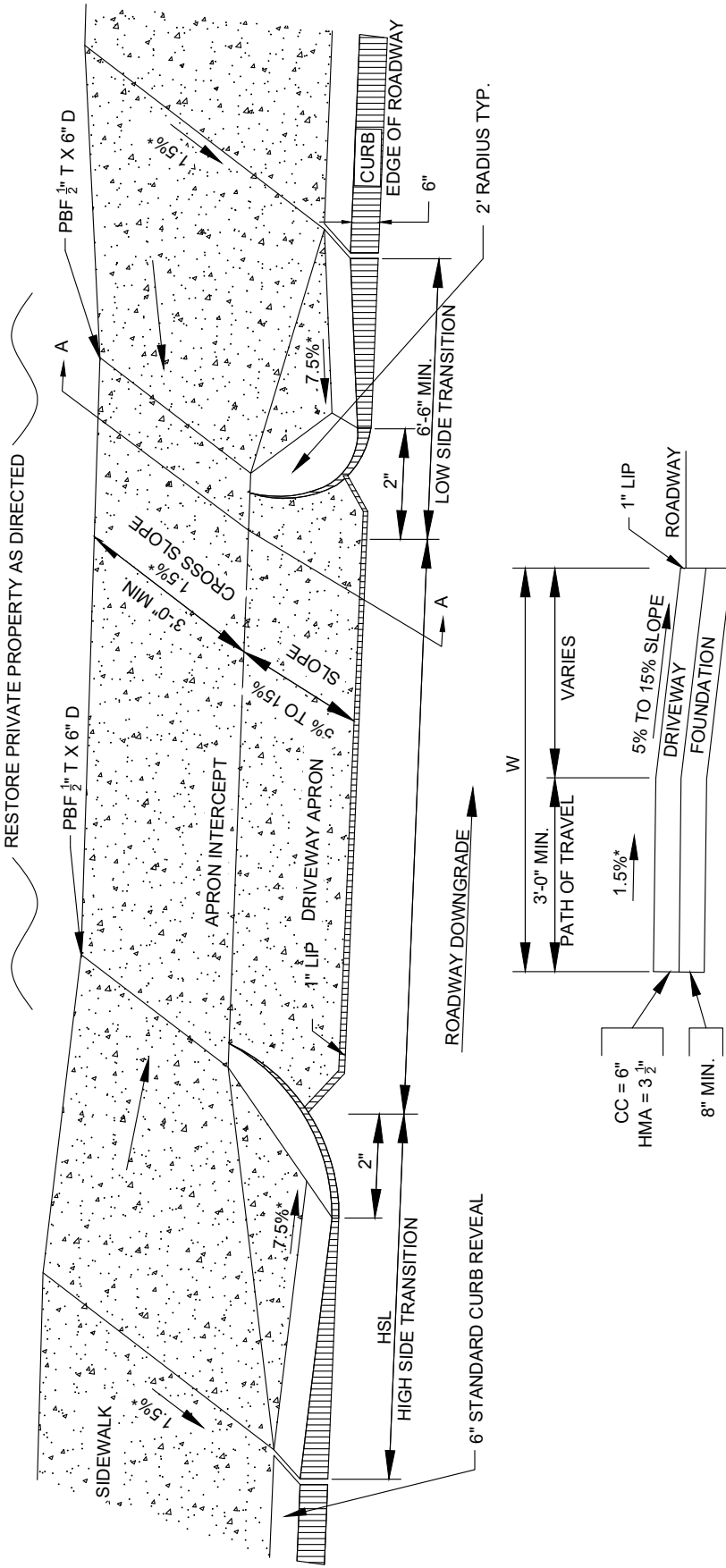

SECTION A-A

LEGEND:

- HSL = HIGH SIDE TRANSITION LENGTH (SEE DETAIL 13)
- W = SIDEWALK WIDTH
- \* = TOLERANCE FOR CONSTRUCTION + 0.5%
- CC = CEMENT CONCRETE
- HMA = HOT MIX ASPHALT
- R = RADIUS

ROADWAY PROFILE GRADE	* HIGH SIDE TRANSITION LENGTH
%	ENGLISH UNITS
=0%	6'-6"
>0% TO 1%	7'-8"
>1% TO 2%	9'-0"
>2% TO 3%	11'-0"
>3% TO 4%	14'-0"
>4% TO 5%	15'-0" MAX

NOTE:

\* BASED ON A DESIGN SLOPE OF 7.5% AND A REVEAL OF 6" .

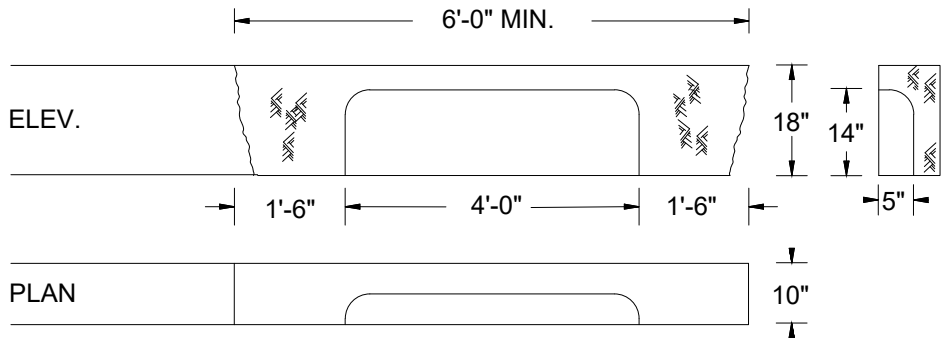
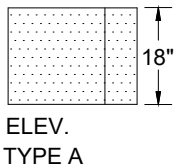
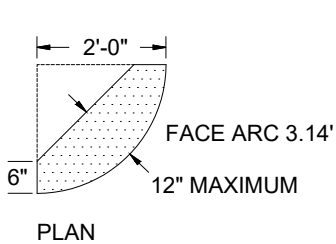

### 7' GRANITE CURB INLET

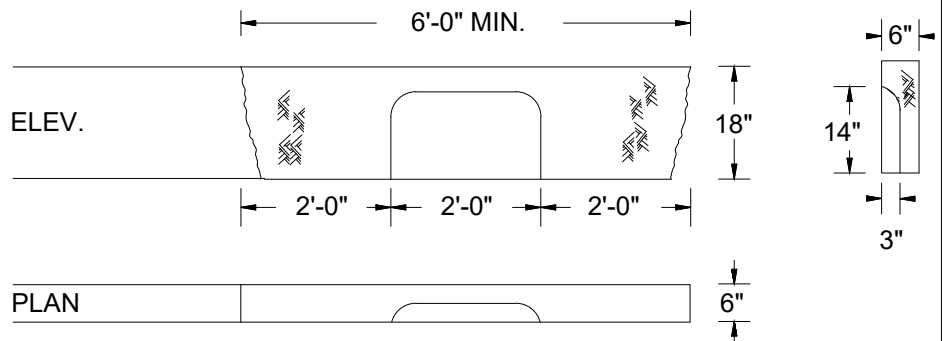
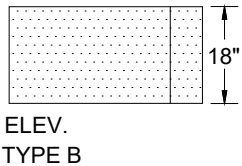
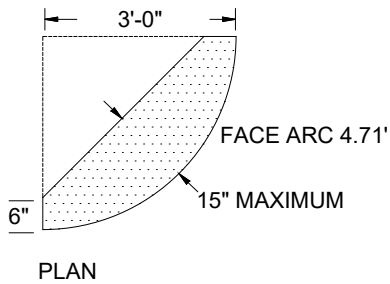

### 6' GRANITE CURB INLET (STRAIGHT TYPE SHOWN)

### CURVED CURB CORNERS (CORNER BLOCKS)

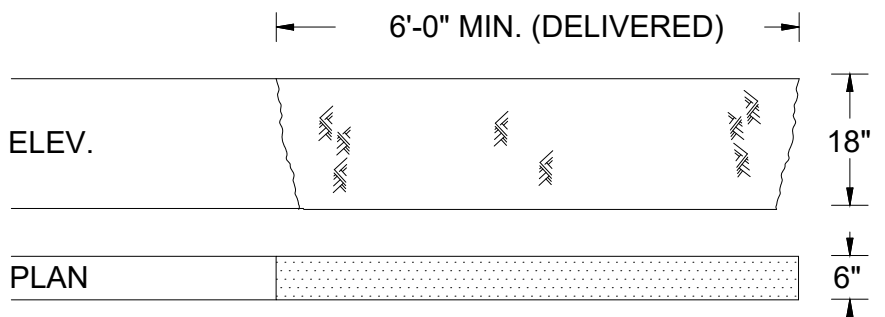
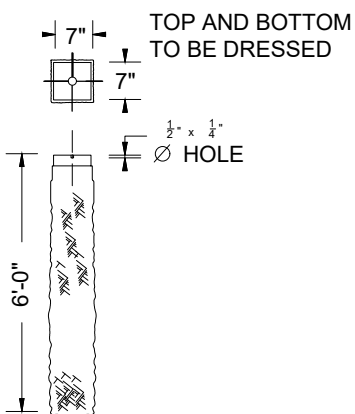

### STRAIGHT AND CURVED CURB

NOTE: ALL CURBING COMPONENTS SHALL BE SPLIT  
FACE WITH A SAWN TOP AND BOTTOM.

#### IMPORTANT NOTE:

ALL BOUNDS ARE TO SET ACCURATELY  
FROM REFERENCE POINTS GIVEN BY THE PLS.  
THE CONTRACTOR SHALL REMOVE AND RESET ALL  
BOUNDS FOUND TO BE INACCURATE.

### STONE BOUNDS

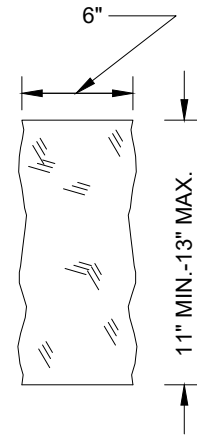
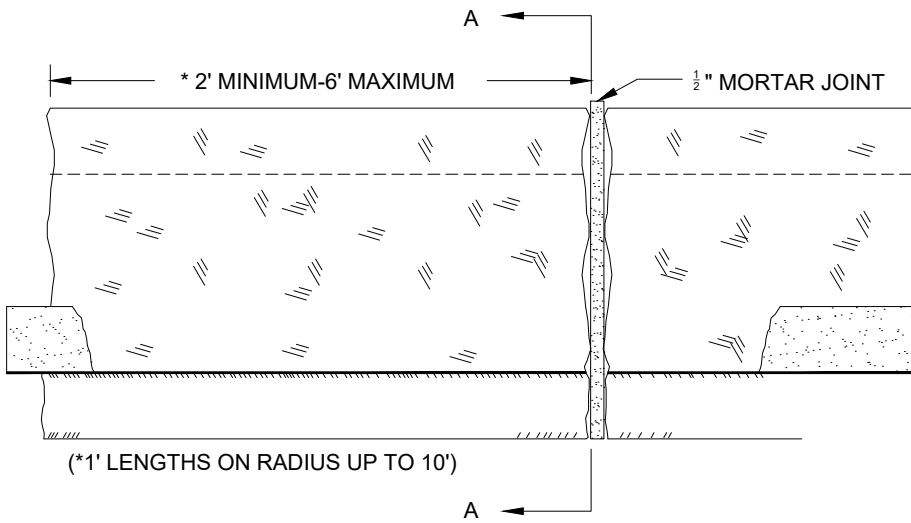

END VIEW

ELEVATION

TYPE SB EDGE CURB  
SAWN TOP/SPLIT FACE

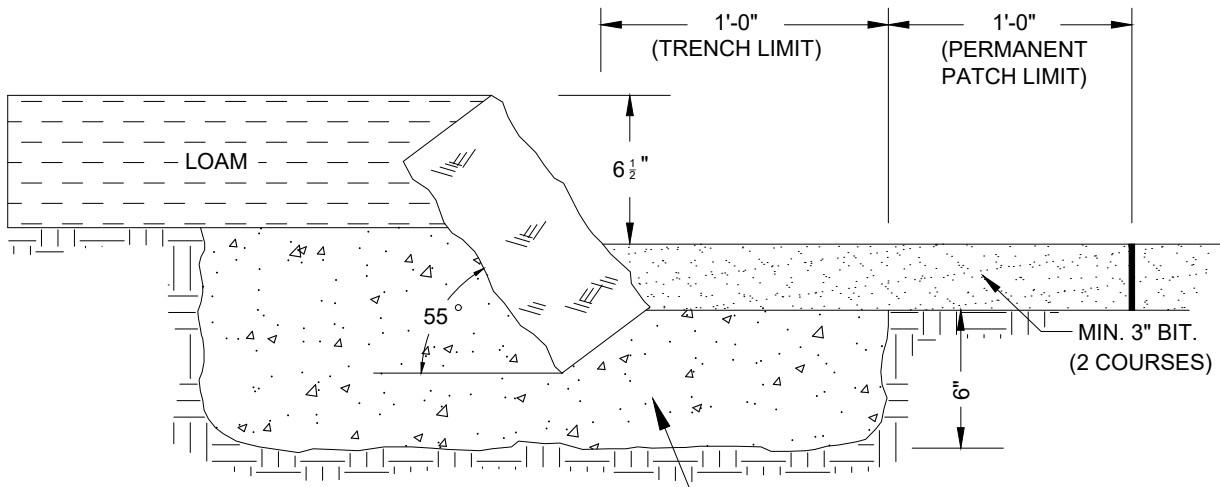

SECTION A-A

SET IN TYPE 'B' CONCRETE



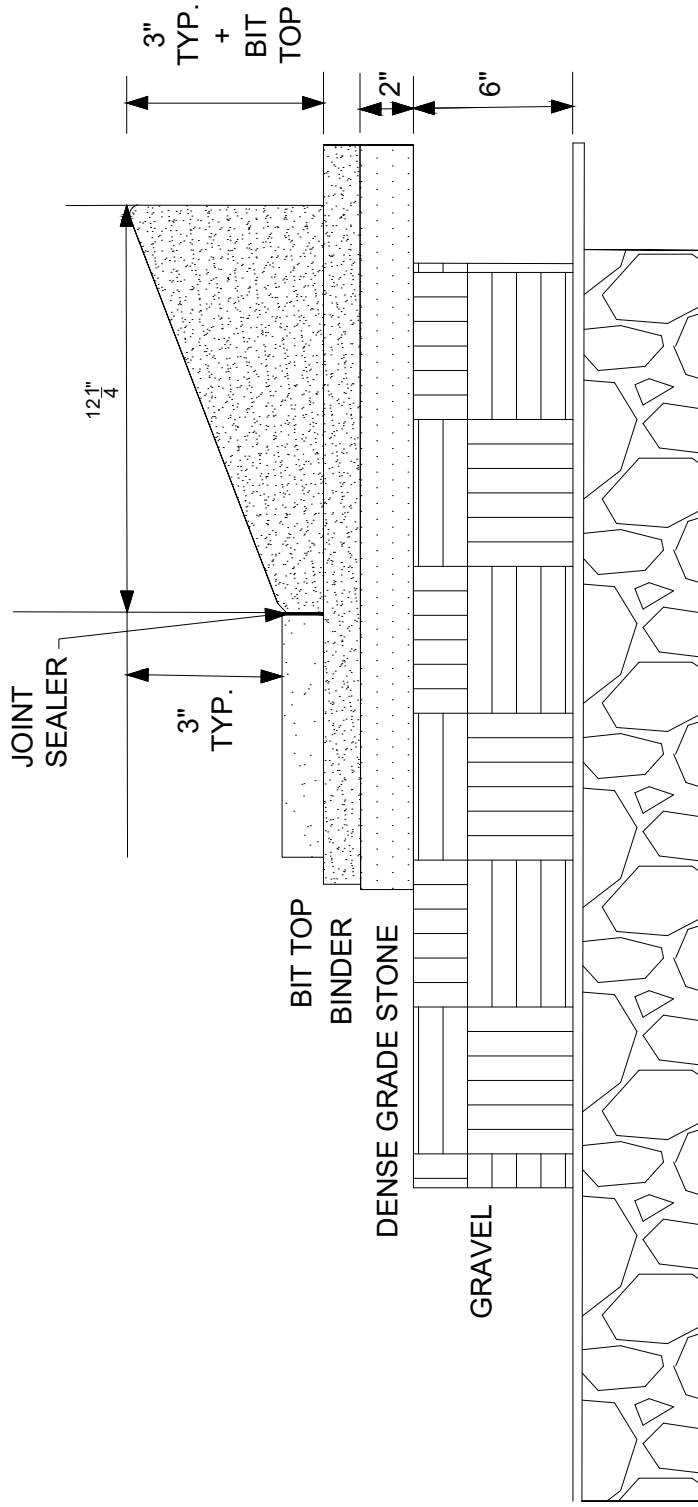

BITUMINOUS CAPE COD BERM  
 (INSTALLED ON TOP OF BINDER COURSE & TACK COATED TO BINDER COURSE)

NTS

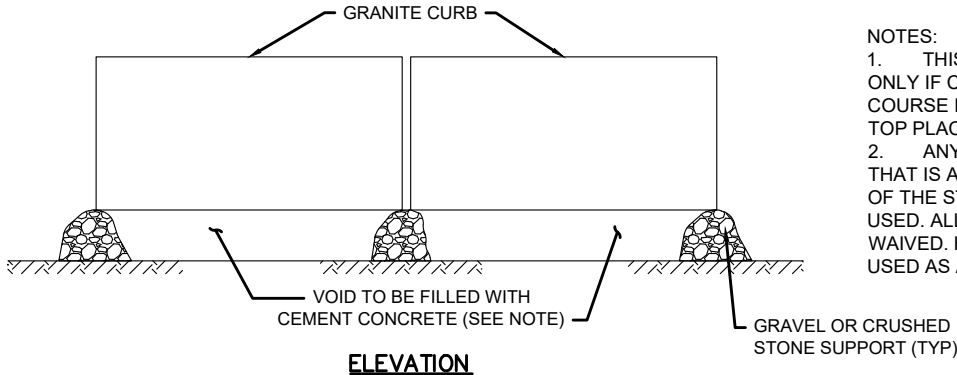

- NOTES:
1. THIS PROCEDURE IS APPLICABLE ONLY IF CURB IS TO BE SET AFTER BASE COURSE IS IN PLACE PRIOR TO BINDER AND TOP PLACEMENT.
  2. ANY DESIGNATED CEMENT CONCRETE THAT IS ACCEPTABLE UNDER SECTION M4 OF THE STANDARD SPECIFICATIONS MAY BE USED. ALL TEST REQUIREMENTS ARE WAIVED. HOT MIX ASPHALT SHALL NOT BE USED AS A SUBSTITUTE.

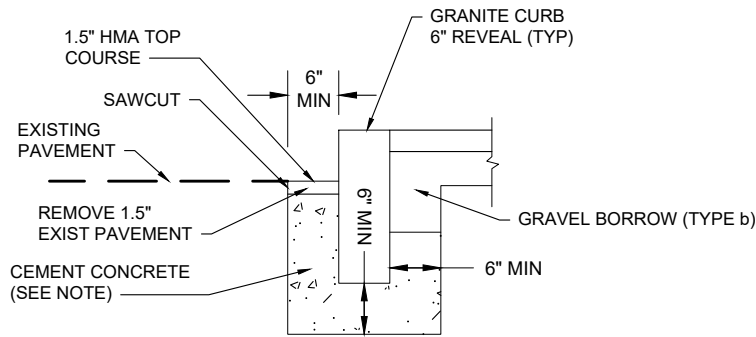

**GRANITE CURB IN EXISTING PAVEMENT**

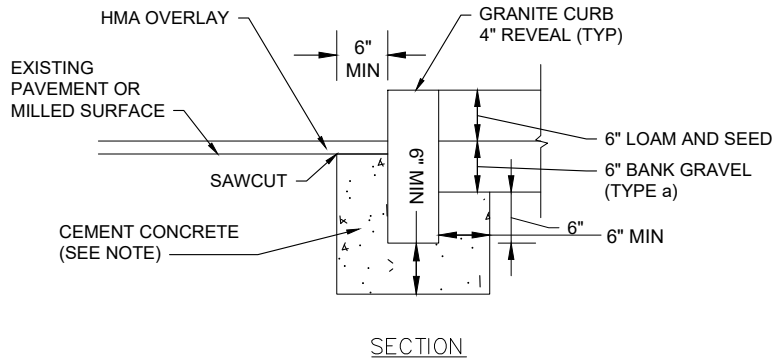

**GRANITE CURB IN EXISTING PAVEMENT WITH OVERLAY**

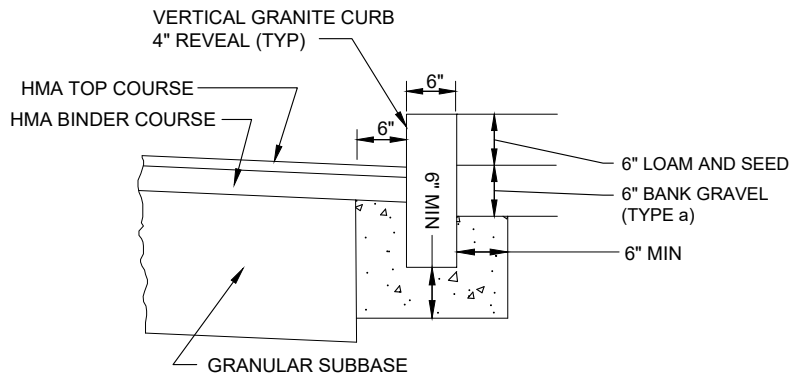

**GRANITE CURB IN FULL DEPTH PAVEMENT**

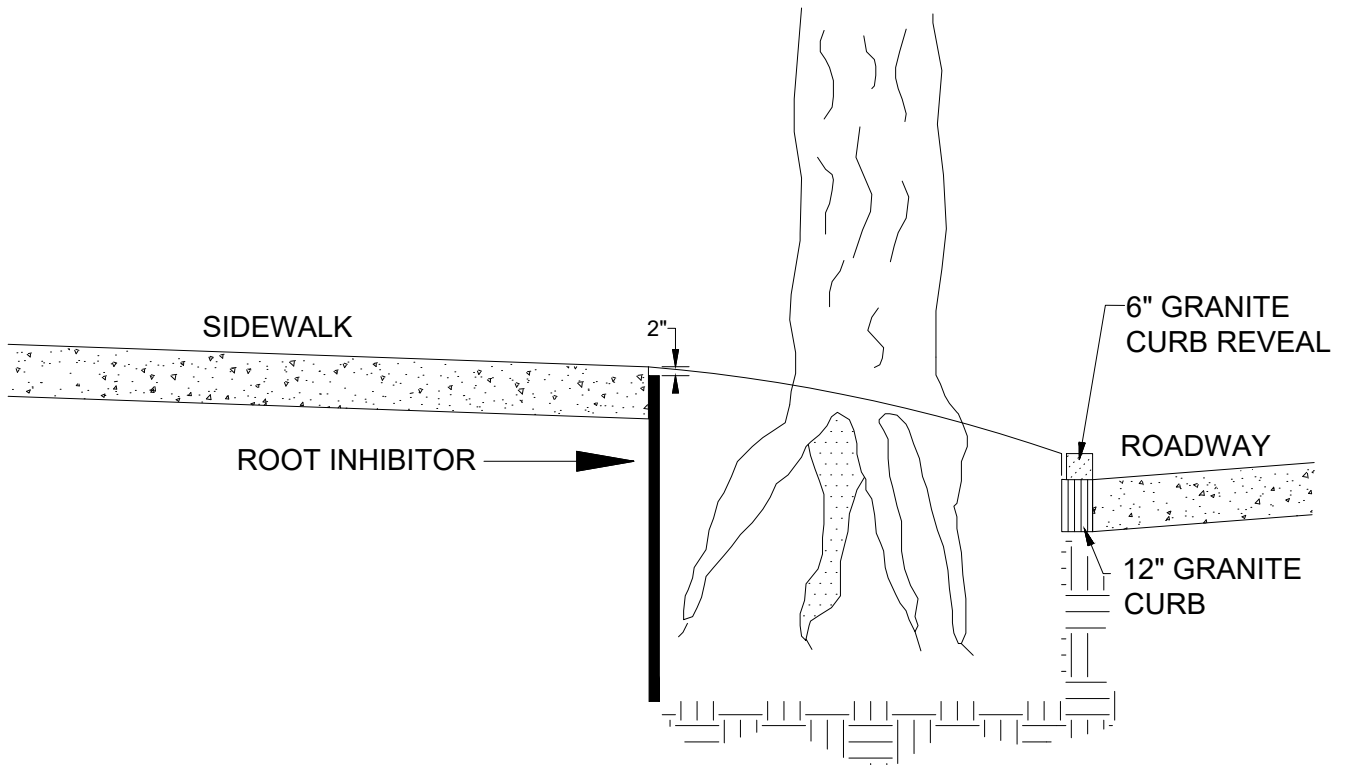
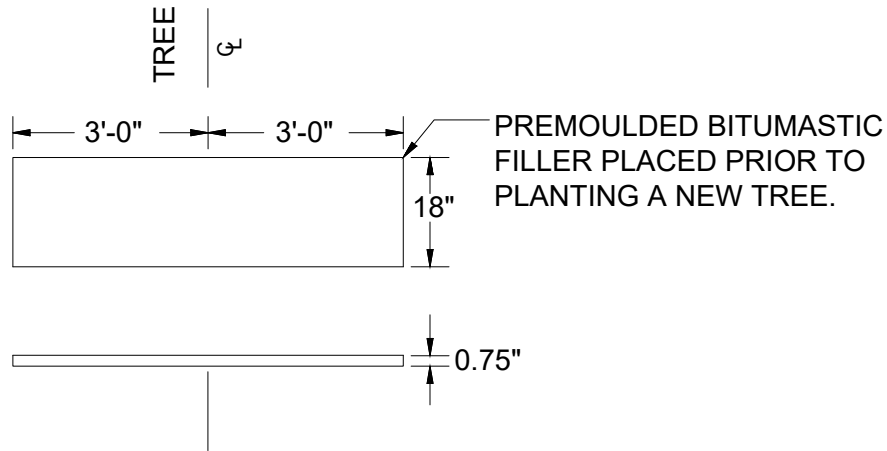
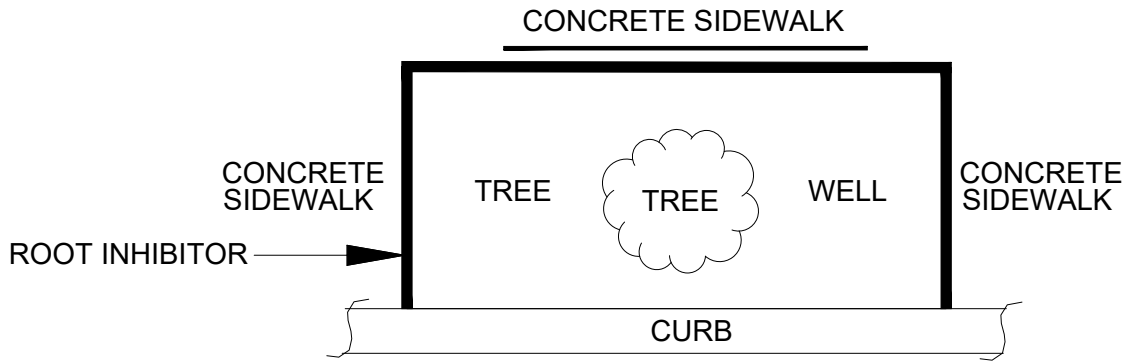

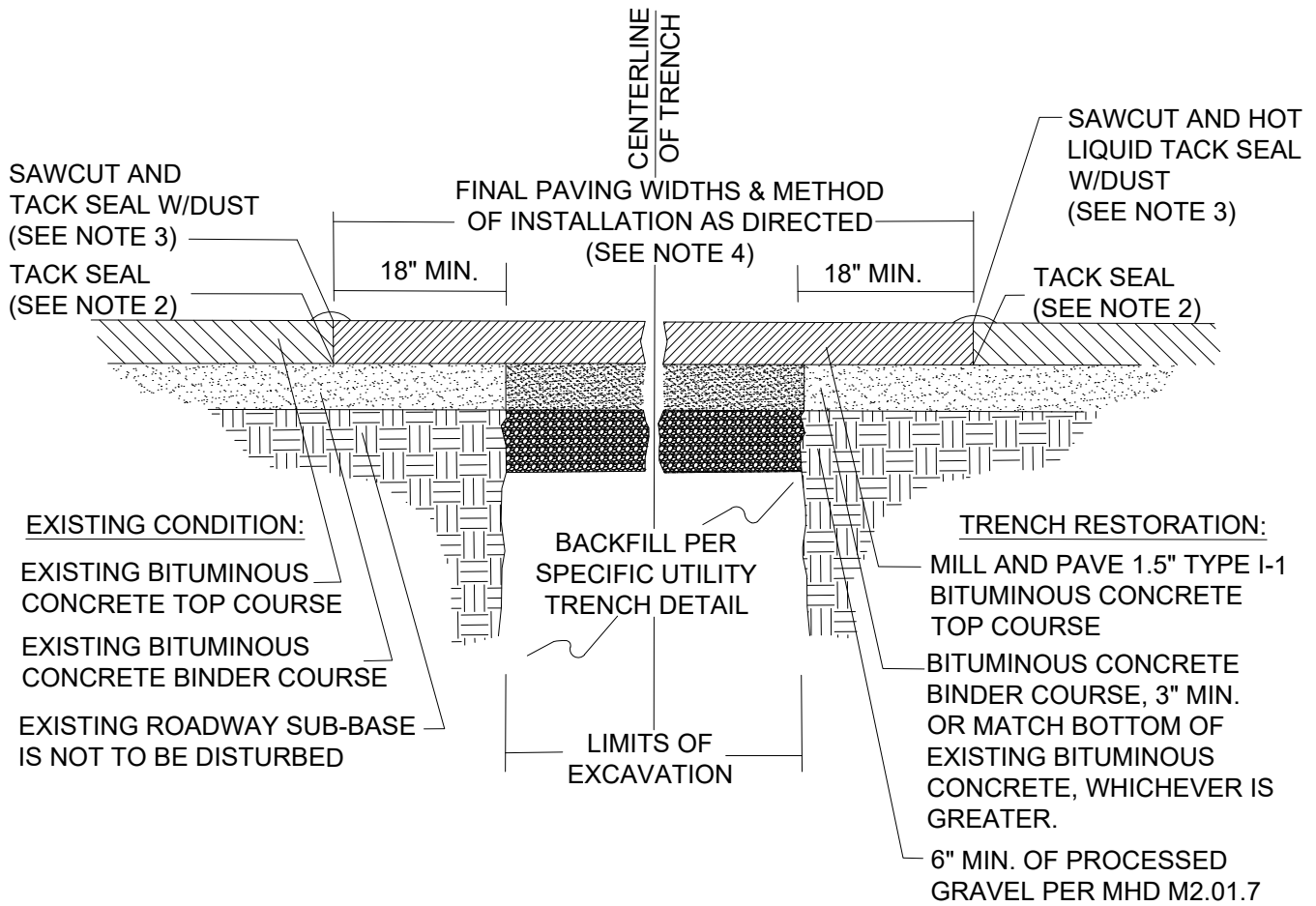

1. ALL INSTALLATION AND MATERIAL SPECIFICATIONS PER MASSDOT DEPARTMENT OF TRANSPORTATION STANDARD SPECIFICATIONS FOR HIGHWAYS AND BRIDGES, 2020 AS AMENDED.
2. ALL EXPOSED BITUMINOUS CONCRETE IS TO BE TACKED PER MASSDOT PRIOR TO NEW BITUMINOUS CONCRETE INSTALLATION.
3. ALL EXPOSED JOINTS ARE TO BE SEALED WITH HOT LIQUID TACK AND STONE DUST.
4. ANY TOP COURSE APPLIED AT A WIDTH OF 6' WIDE OR GREATER IS TO BE PLACED BY MACHINE/BOX SPREADER WHEN & AS DIRECTED BY THE CITY OF NEWTON.
5. SUPERPAVE FOR PAVEMENT

**NOTES:**

1. ALL POSTS ARE TO BE SET PLUMB.
2. ALL FOOTINGS TO BE CEMENT CONCRETE.
3. MAXIMUM DIMENSION TO THE TOP OF THE PARKING METER HEAD SHALL BE 48".

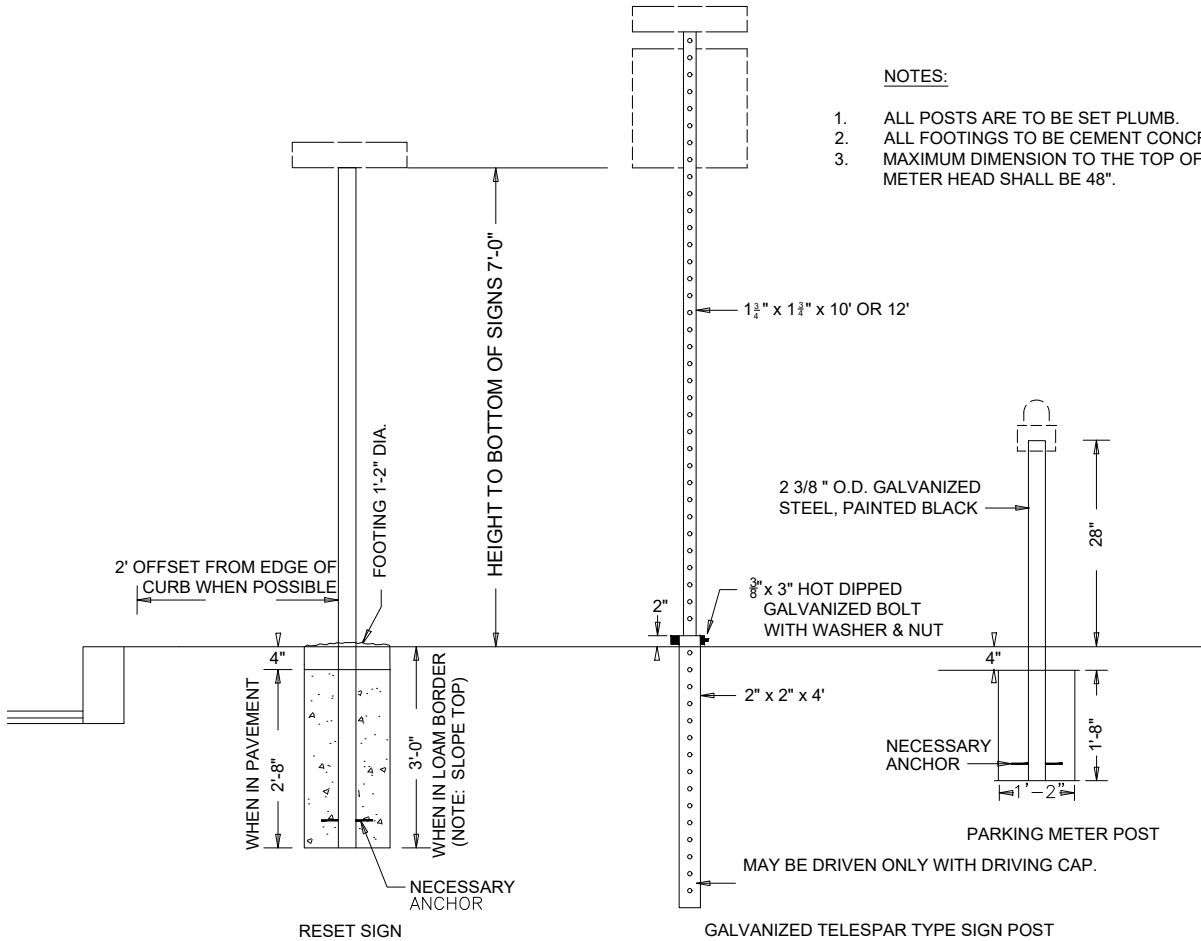

RESET SIGN  
(REMOVE OLD FOOTING & RESET AS SHOWN)

GALVANIZED TELESPAR TYPE SIGN POST  
(NEW INSTALLATIONS OR AS DIRECTED)

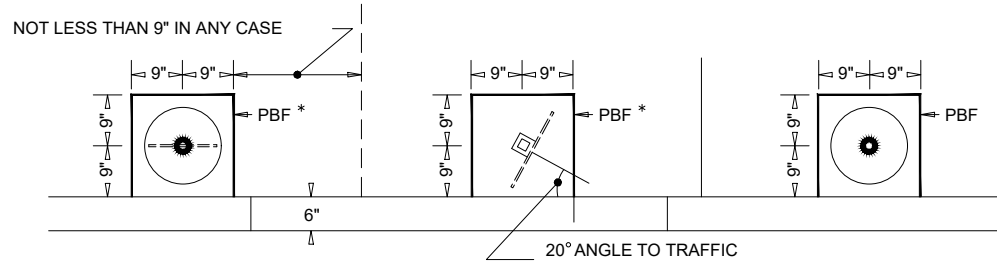

\* PREMOULDED BITUMASTIC FILLER TO BE USED ONLY WHEN POST IS SET IN CEMENT CONCRETE SIDEWALKS

**NOTES:**

1. MIN. 0.91 GA. EXTRUDED ALUMINUM SIGN BLADE WITH HIGH INTENSITY SHEETING (GREEN BACKGROUND WITH 4" MIN SILVER COPY AND 3/8" SILVER BORDER.)
2. EACH SIGN SHALL HAVE LEGEND ON BOTH SIDES.
3. POSTS SHALL HAVE A MIN. 0.64" WALL ON BOTH SIDES
4. WHEN APPLICABLE: STREET SIGNS ARE REQUIRED TO BE INSTALLED BY THE DEVELOPER, FOLLOWING THE INSTALLATION OF THE BASE COURSE OF THE ROADWAY.
5. ALL SIGNS SHALL BE MAINTAINED BY THE DEVELOPER OR CONTRACTOR UNTIL ALL WAYS ARE ACCEPTED BY THE CITY.
6. ALL POSTS ARE TO BE SET PLUMB.
7. ALL FOOTINGS ARE TO BE CEMENT CONCRETE CLASS B MIN.

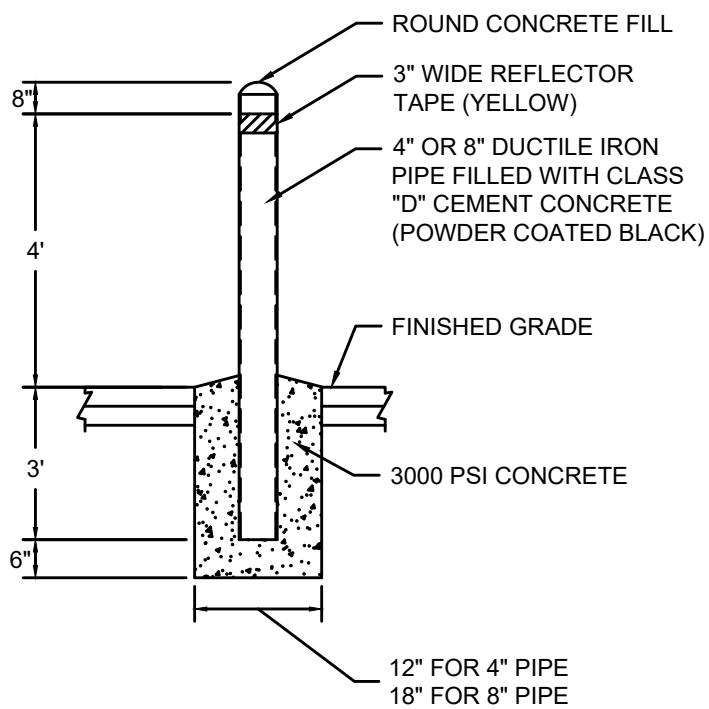

**PROPOSED FOUR OR EIGHT INCH (4" OR 8") DIAMETER  
CONCRETE FILLED DUCTILE IRON FIELD FABRICATED  
BOLLARD**

NOTE: THE (CUT) EDGES ARE TO BE BEVELED & RENDERED  
SAFE PRIOR TO PLACEMENT OF THE DOME-TOPPED  
CONCRETE FILLER MATERIAL

**CDF ONLY IN PAVED AREAS!**

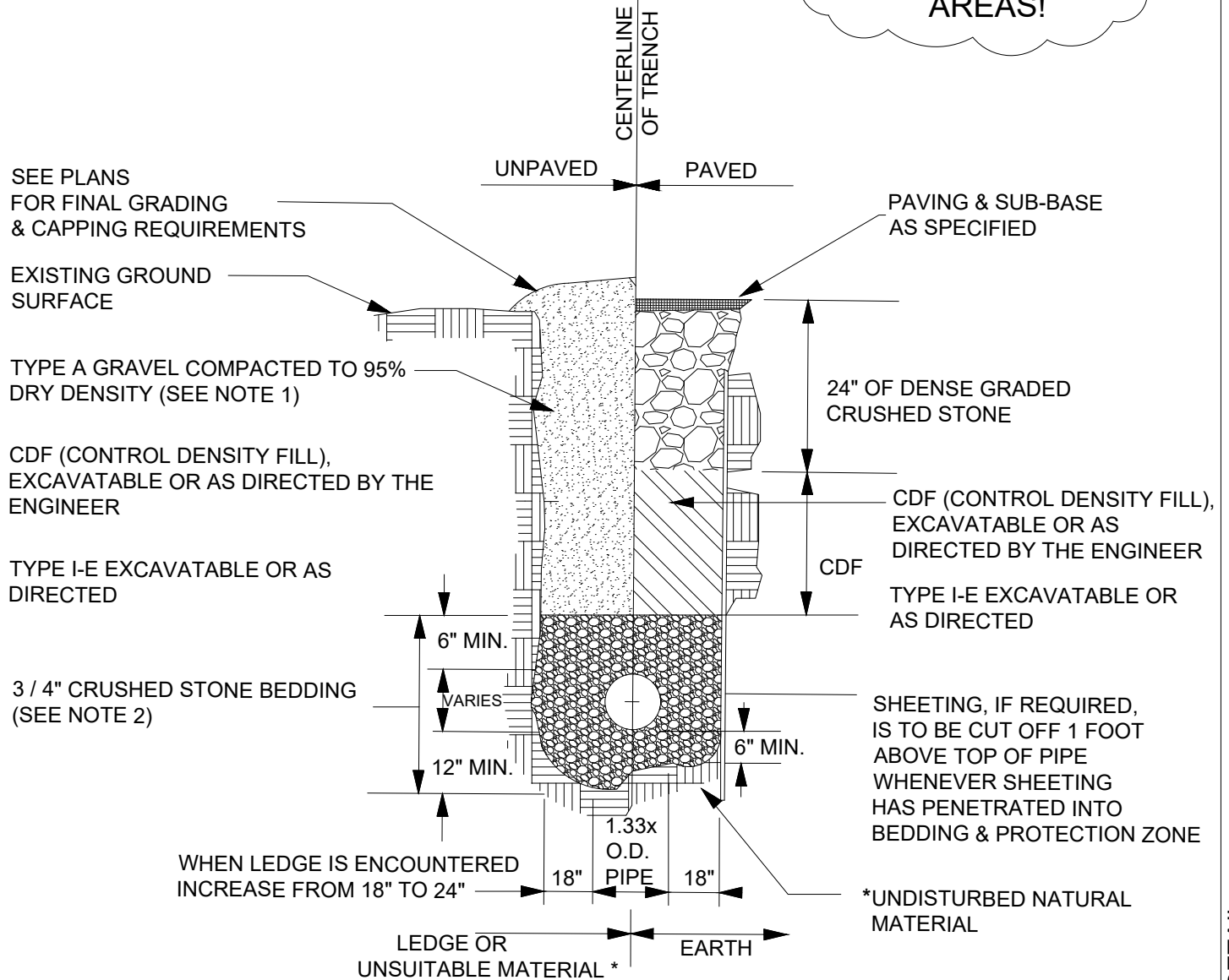

- \* SUITABILITY OF MATERIAL IS TO BE DETERMINED BY THE CITY OF NEWTON.
- 1. GRAVEL BORROW SHALL CONFORM TO MASSDOT SPECIFICATION M1.03.0
- 2. CRUSHED STONE BEDDING SHALL CONFORM TO MASS HIGHWAY SPECIFICATION M2.01.1

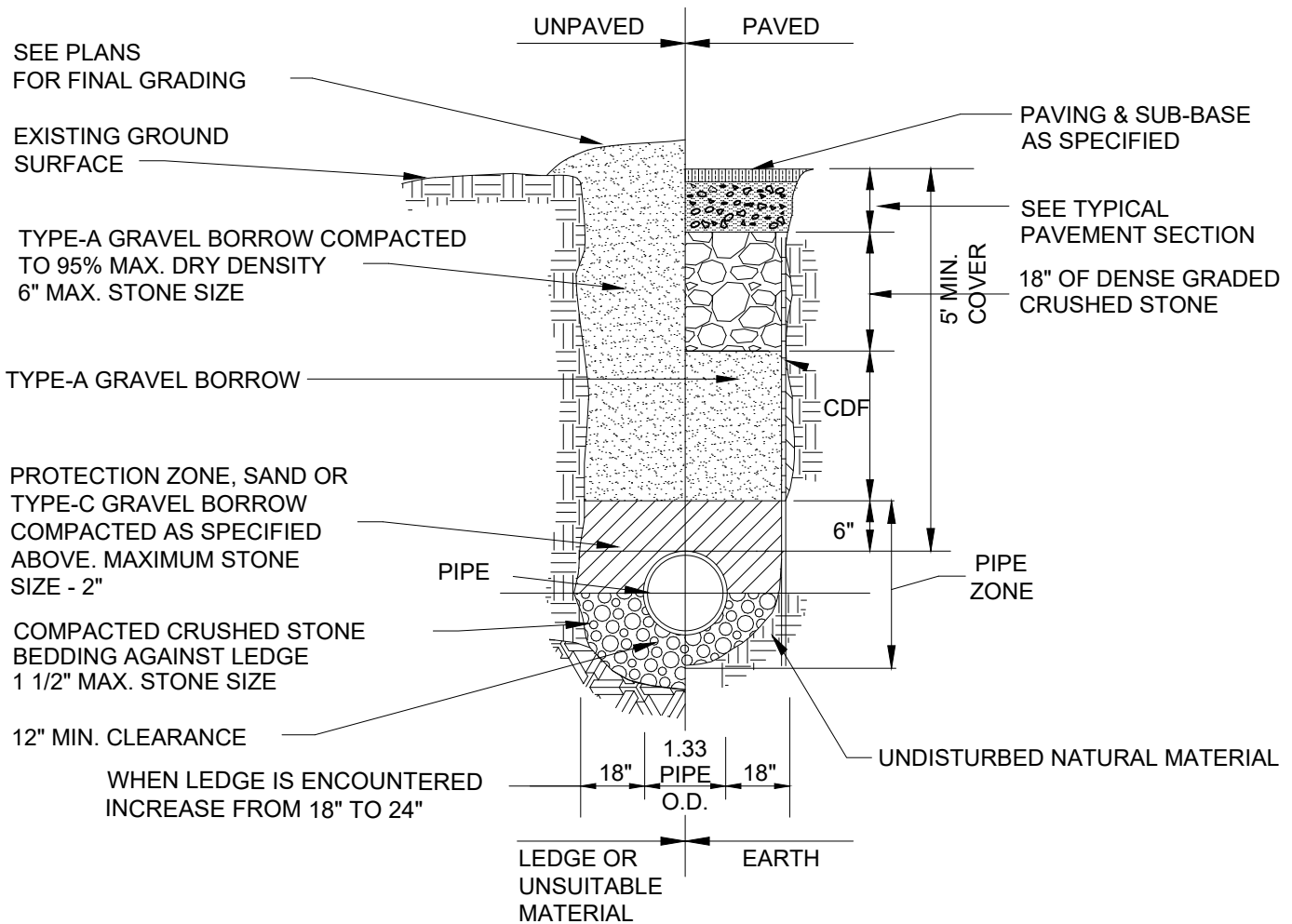

\* SUITABILITY OF MATERIALS IS TO BE DETERMINED BY THE CITY OF NEWTON

1. GRAVEL BORROW SHALL CONFORM TO MASS HIGHWAY SPECIFICATION M1.03.0
2. CRUSHED STONE BEDDING SHALL CONFORM TO MASSDOT SPECIFICATION M2.01.1

NOTE: TRENCHBOX OR SHEETING SHALL MEET OSHA STANDARDS.



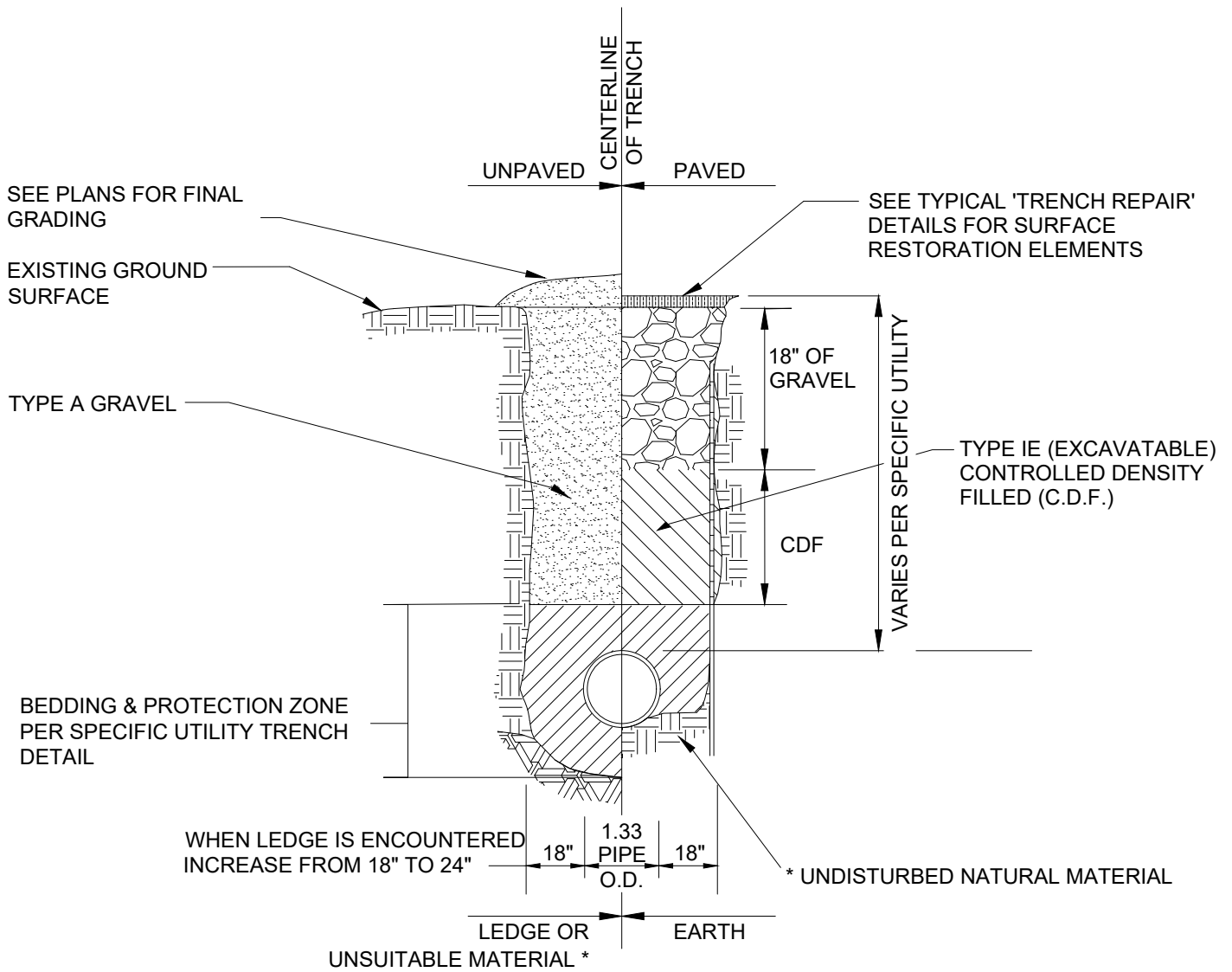

\* SUITABILITY OF MATERIAL IS TO BE DETERMINED BY THE CITY OF NEWTON.

NOTE: TRENCHBOX OR SHEETING SHALL MEET OSHA STANDARDS.

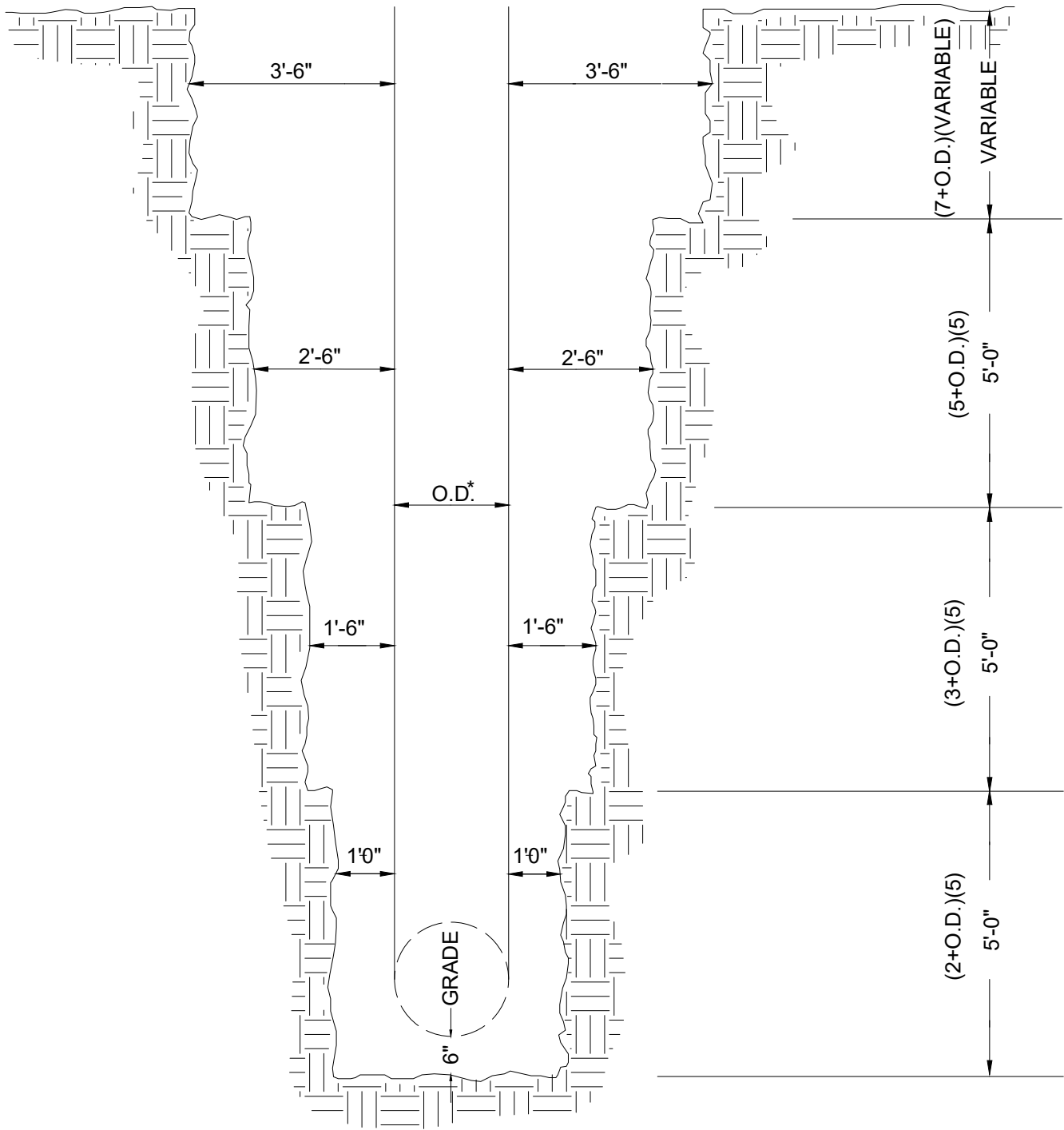

\* OUTSIDE DIAMETER OF INSTALLED PIPE

PLAN VIEW

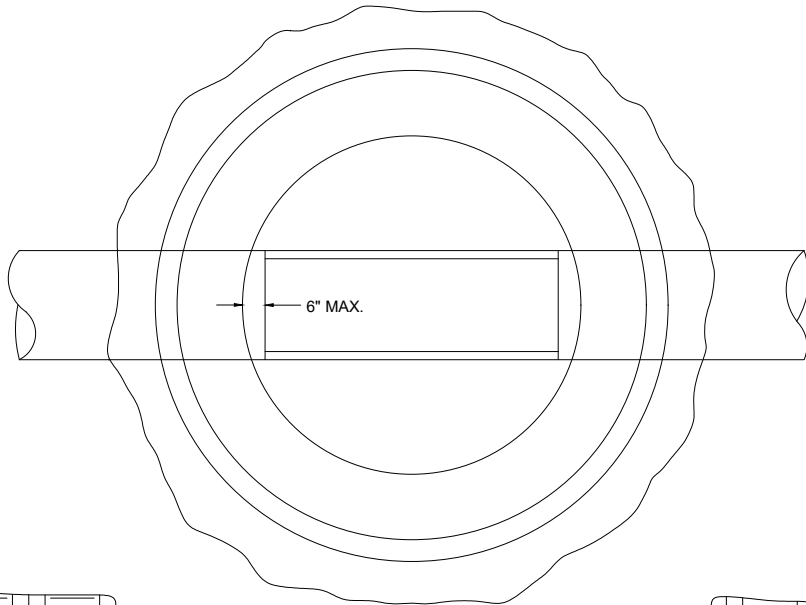

ELEVATION

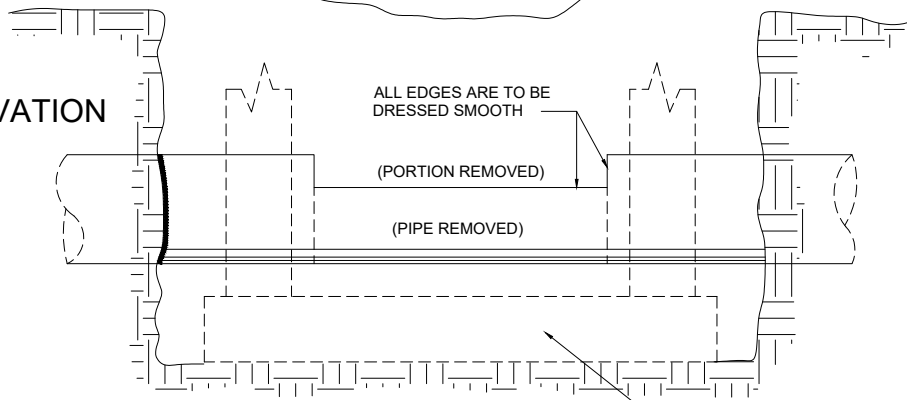

END VIEW

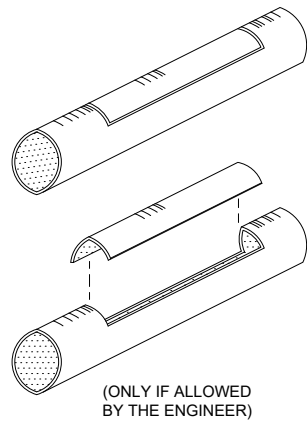
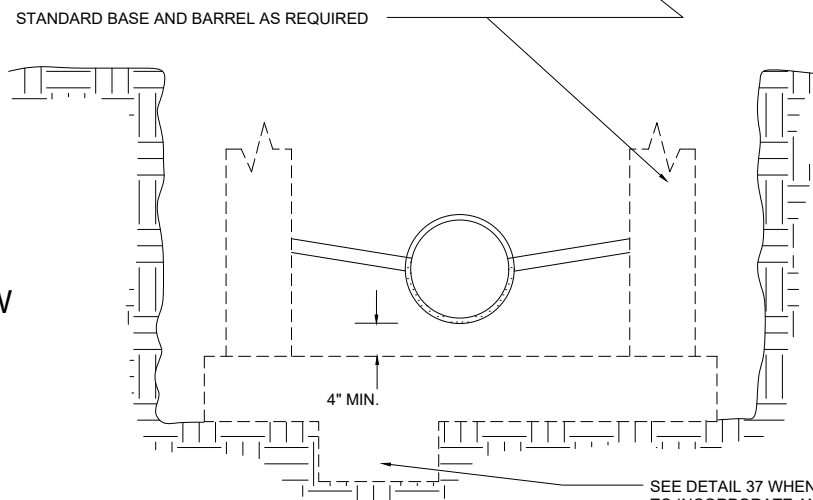

SEE DETAIL 37 WHEN IT IS DIRECTED TO INCORPORATE AN UNDERDRAIN INTO THE STRUCTURE.

KERF & CUT PIPE: ONLY A POWER CUT-OFF SAW AND BLADE MAY BE USED TO SEPARATE PORTIONS OF PIPE.

THIS METHOD OF BUILDING A MANHOLE OVER AN EXISTING PIPE WILL ONLY BE ALLOWED WHEN CONDITIONS WARRANT, THEN ONLY WHEN DIRECTED BY THE ENGINEER. IT IS NOT TO BE CONSIDERED WHEN PLACING A BID.

WHEN PLACING A BID WHERE A MANHOLE IS TO BE BUILT OVER AN EXISTING PIPE IT IS TO BE ASSUMED THE SECTION(S) OF PIPE WILL BE REMOVED AND A STANDARD STRUCTURE WILL THEN BE BUILT.

**MANHOLES**

**CATCH BASINS**

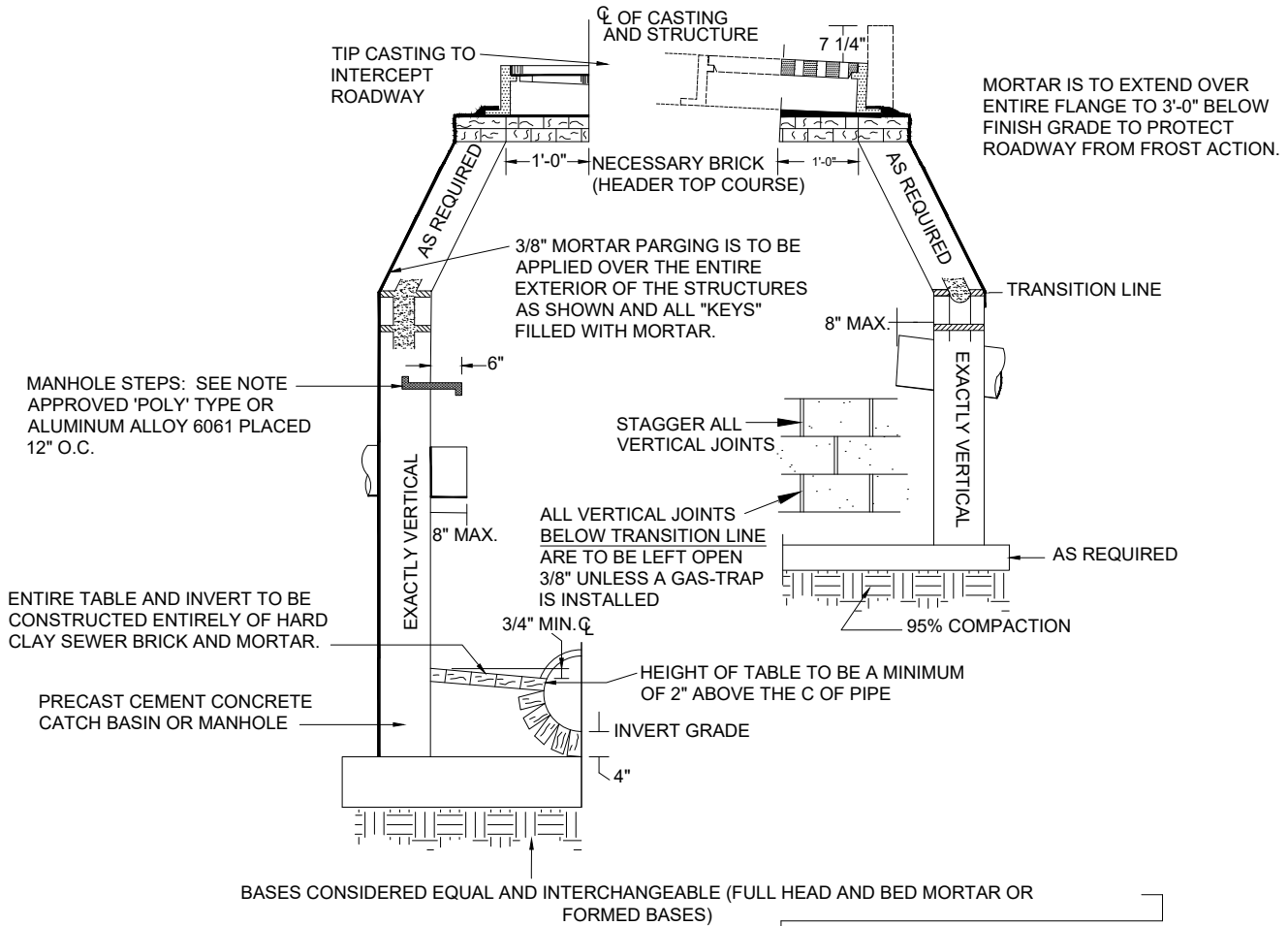

UNDER 10'	6" POURED 3000 lb. CEMENT CONCRETE. 8" PRECAST CEMENT CONCRETE BLOCK 8" HARD CLAY BRICK
OVER 10'	8" POURED 3000 lb. CEMENT PRECAST CONCRETE 10" HARD CLAY BRICK

**MORTAR:** ALL MORTAR TO BE ONE PART CEMENT TO TWO PARTS CLEAN WASHED SAND BY VOLUME.

**BLOCK:** ALL BLOCK IS TO BE SOLID PRECAST CEMENT CONCRETE.

**BRICK:** ALL BRICK IS TO BE COILED HARD CLAY TYPE M SEWER BRICK.

**MANHOLE STEPS:**

ALL MANHOLE STEPS TO BE PLACED WITHIN THE STRUCTURE VERTICALLY ABOVE ONE ANOTHER AND PLACED SO AS NOT TO BE INTERFERED WITH BY MANHOLE STRUCTURAL COMPONENTS OR INFLUENTS. STEPS TO EXTEND INTO CONE SECTION.

**COMPACTION AROUND FRAMES:**

AFTER THE FRAME HAS BEEN SET BOTH THE BACKFILL MATERIAL AND THE SUBSEQUENT BITUMINOUS BINDER ARE TO BE INDEPENDENTLY COMPACTED WITH AN APPROVED PNEUMATIC "HAMMER" AND TAMPING BIT. ALL STRUCTURES ARE TO BE BUILT AS SHOWN UNLESS A MODIFICATION IS NECESSARY TO MEET EXISTING FIELD CONDITIONS. NO ADJUSTMENT IN THE BID PRICE WILL BE MADE.

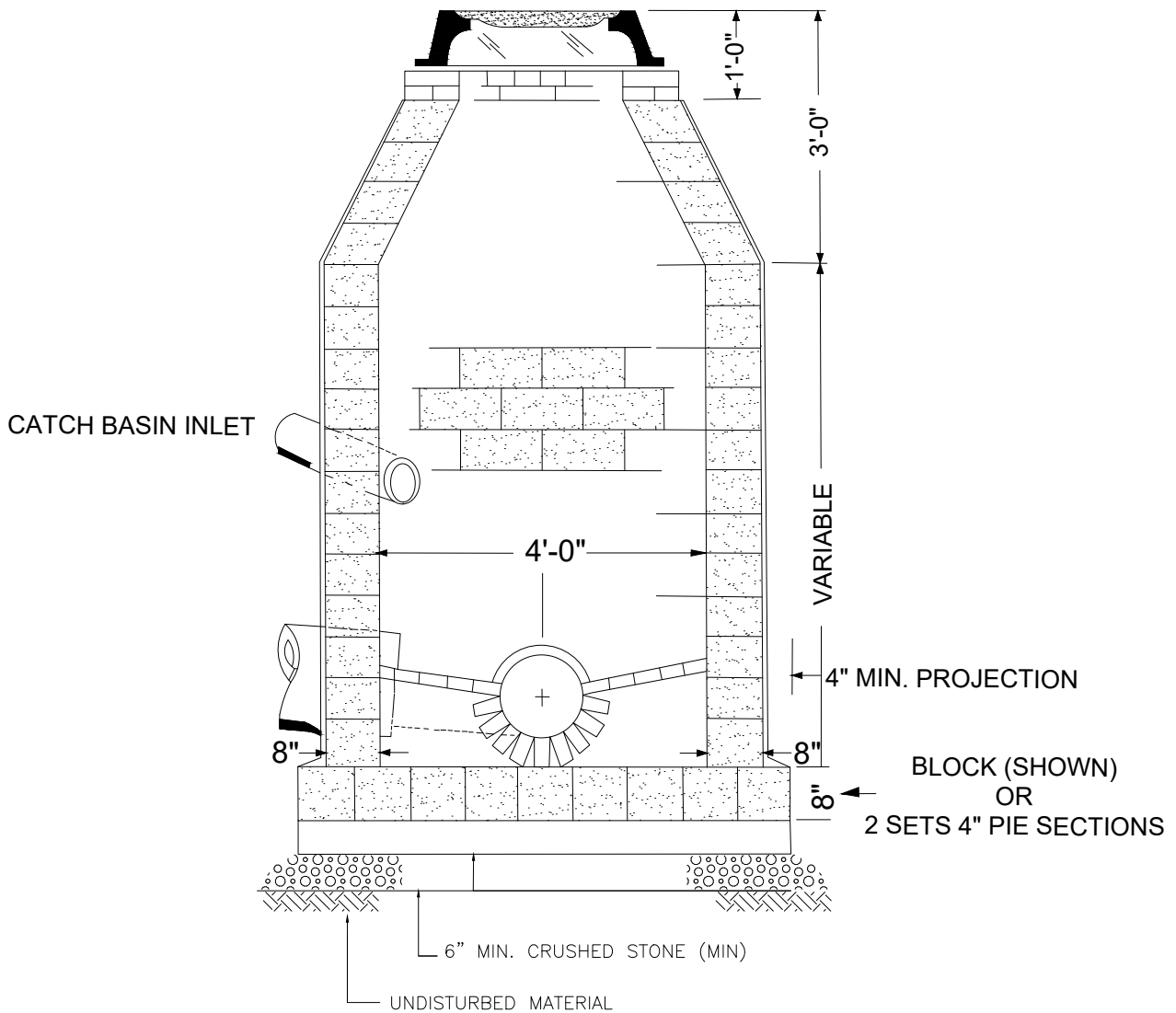
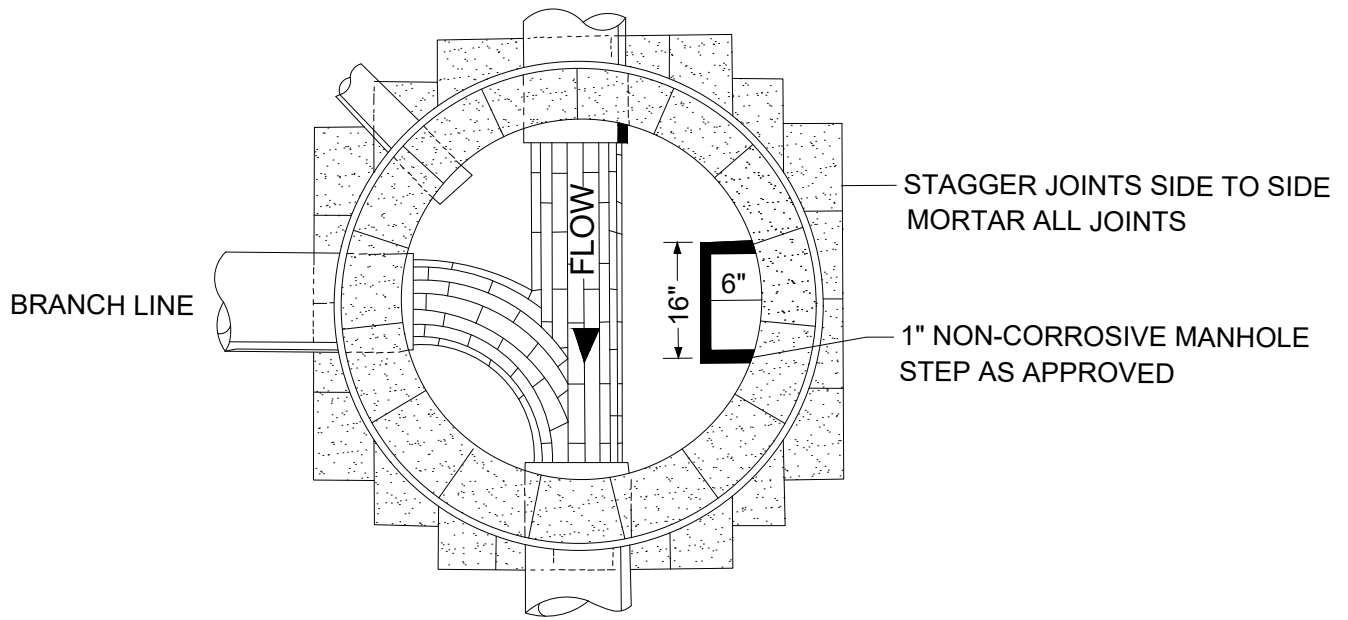

STANDARD DRAIN MANHOLE (CONCRETE BLOCK TYPE)

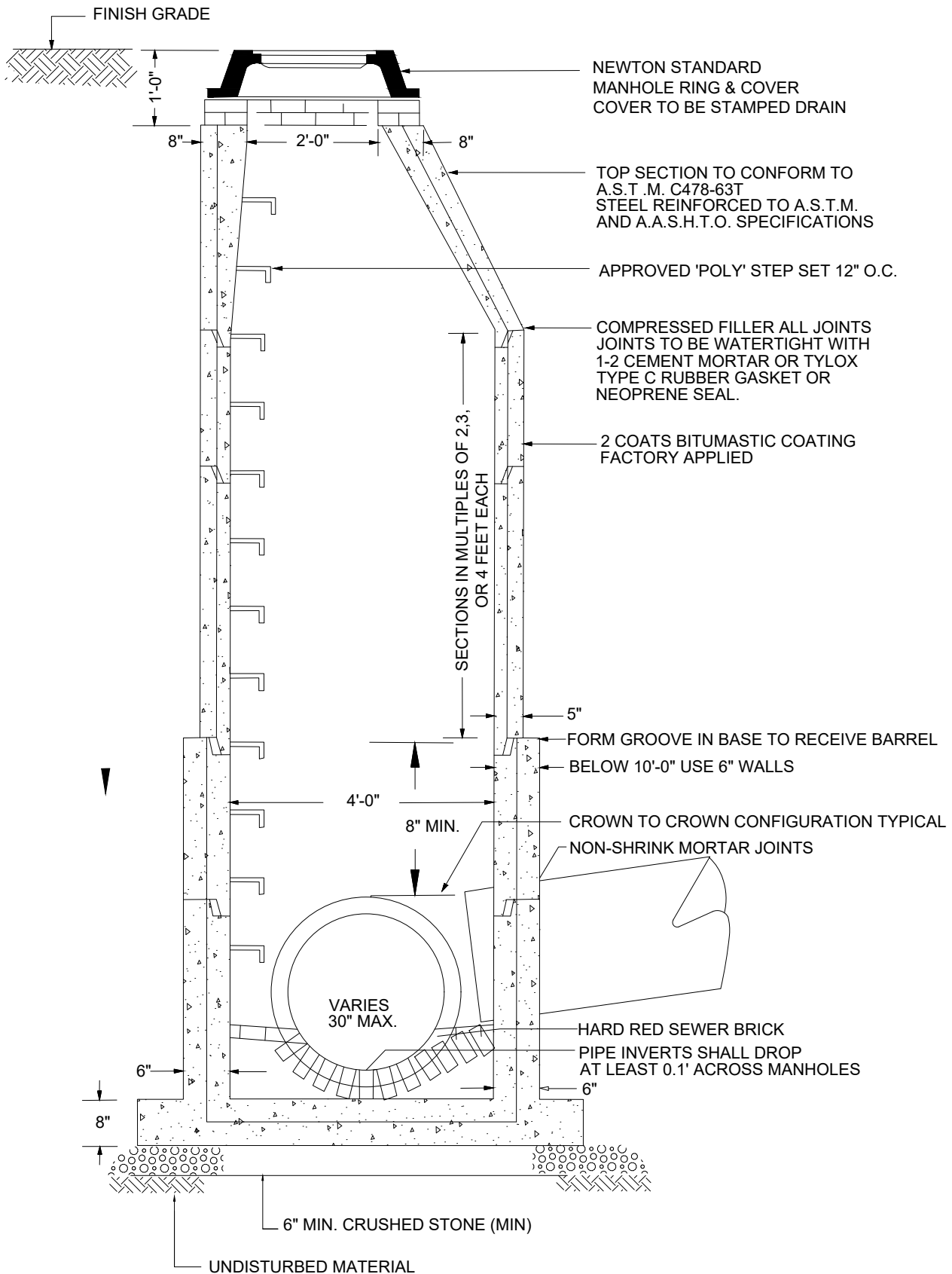

8" AUXILIARY FLANGE INTEGRALLY CAST (F DEPTH EXCEEDS 9')

OPENINGS ARE TO BE MANUFACTURED INTO THE STRUCTURE

H20 LOADING

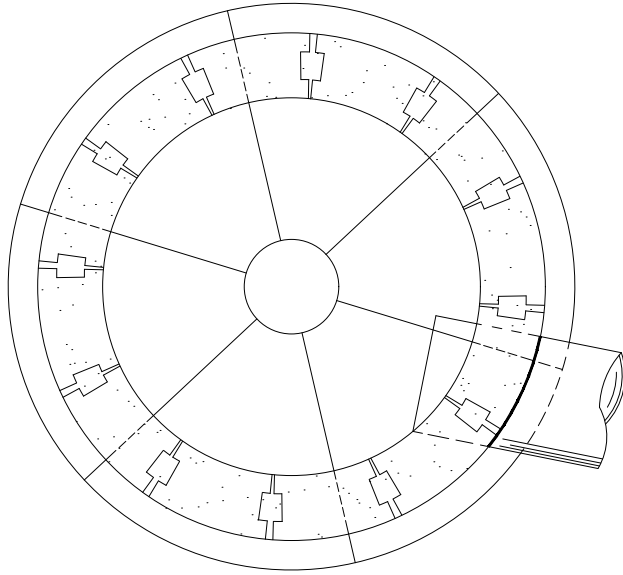

ALTERNATE: 4 PIECE SQUARE RING TO REPLACE TOP BLOCK ROW.

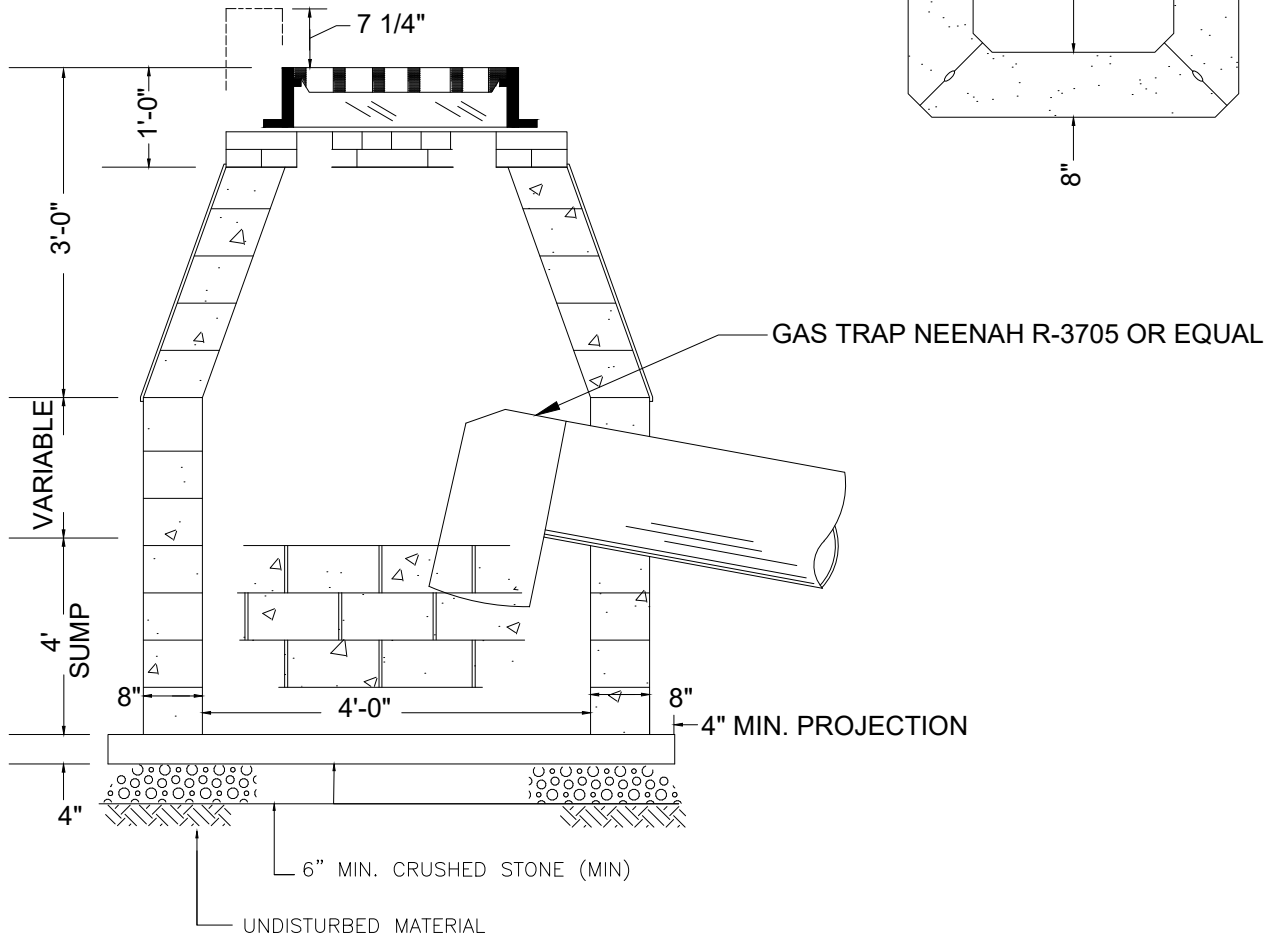
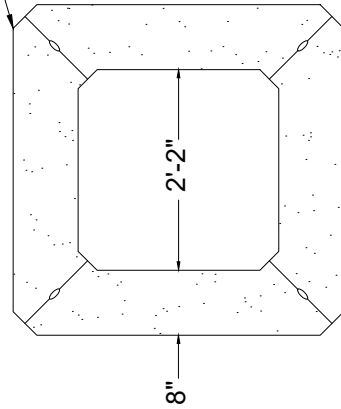

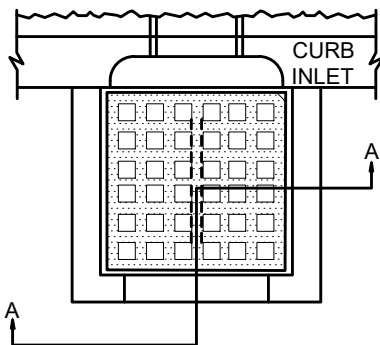

NOTES:

1. WHERE CURB INLET IS NOT USED INSIDE HORIZONTAL DIMENSIONS OF GUTTER INLET TO BE  $24" \pm 1"$  X  $24" \pm 1"$  IN WHICH CASE AND UNLESS OTHERWISE DIRECTED, A STANDARD 4-FLANGE FRAME TO BE USED.
2. BRICKS MAY BE USED BETWEEN TOP COURSE AND FRAME FOR GRADE ADJUSTMENT.
3. FOR DESCRIPTION, MATERIALS AND CONSTRUCTION METHODS, SEE MASSDOT SPECIFICATIONS.

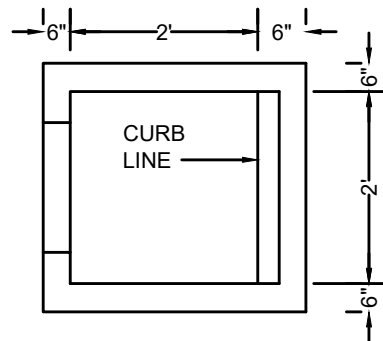

SECTION C-C

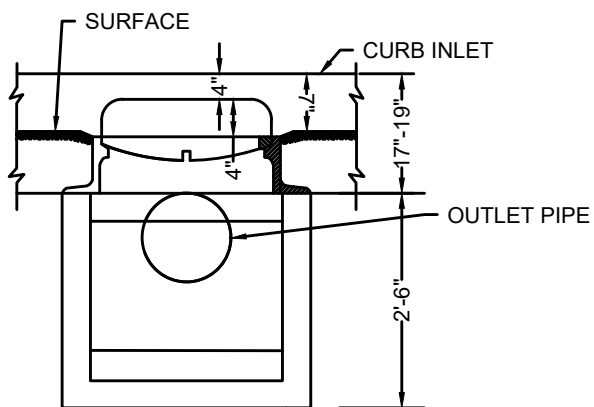

SECTION A-A

4000 PSI CEMENT CONCRETE  
(SEE SUBSECTION 201 OF MASSDOT SPECIFICATIONS  
FOR DESIGN REQUIREMENTS)  
OR PRECAST CONCRETE

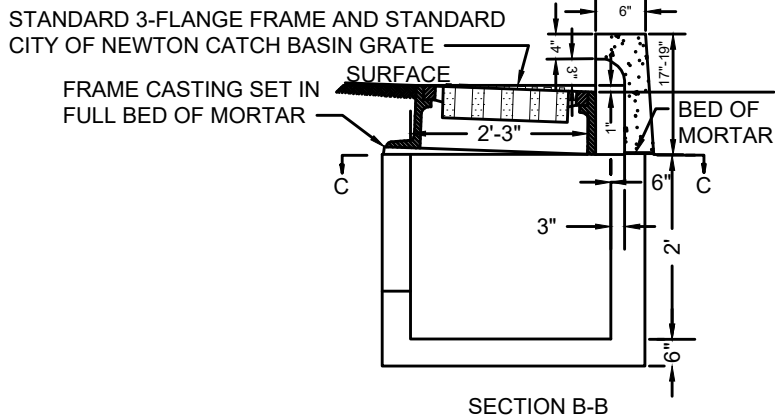

SECTION B-B

NOT TO SCALE



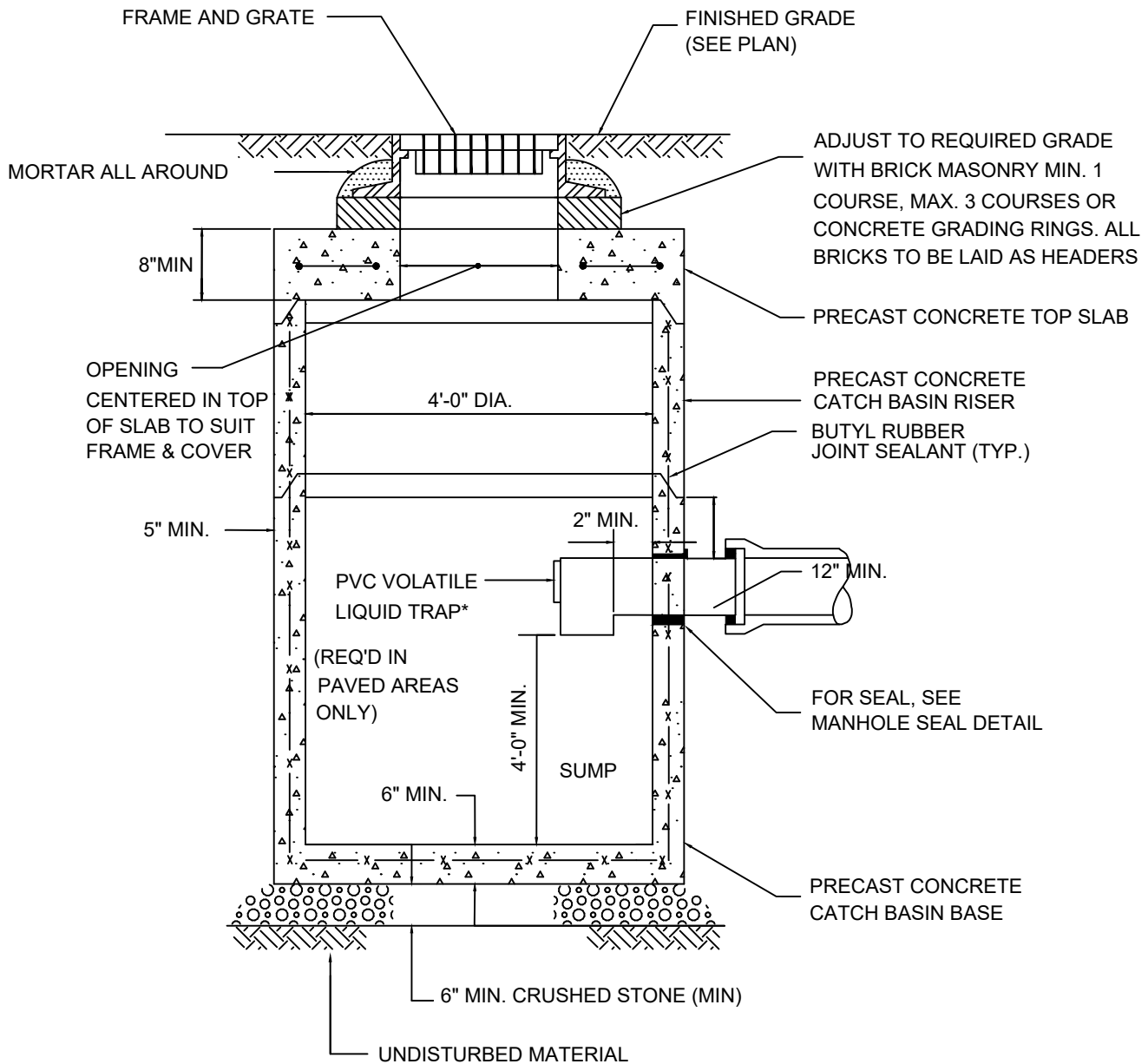

\*GAS TRAP SHALL BE NEENAH R-3705 OR APPROVED EQUAL

**NOTE:**

1. STEEL REINFORCING TO MEET OR EXCEED H2O LOADING
2. TOP SLAB SHALL BE CONCENTRIC WHEN NO CURBING IS USED  
ECCENTRIC WHEN CURBING IS USED

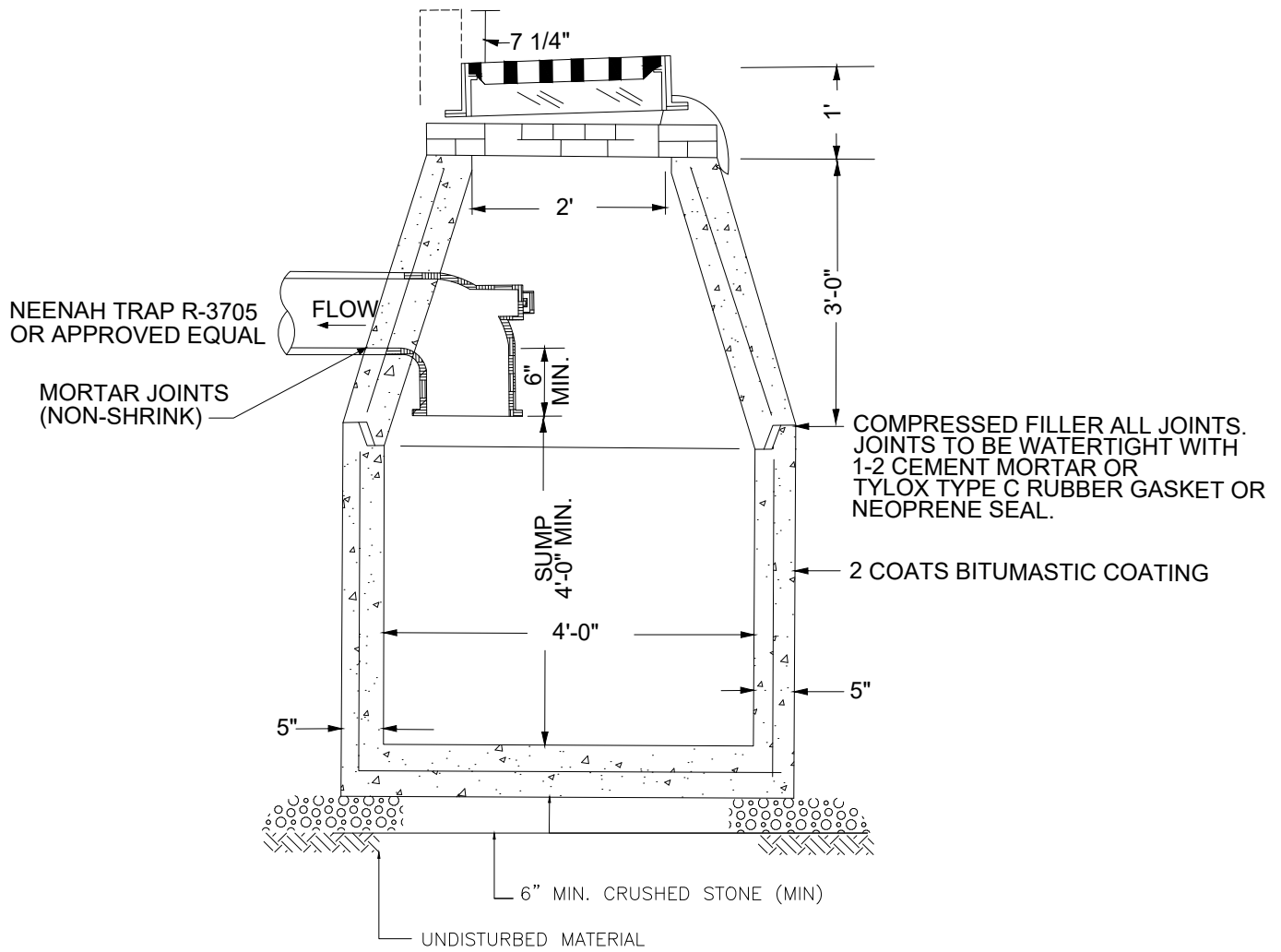

**H2O LOADING**

4000 PSI @ 28 DAY DENSITY 150 PCF PORTLAND  
 CEMENT TYPE I OR III PER ASTM C150-81  
 REINFORCING PER ASTM A615 FOR WIRE FABRIC

WHERE GAS-TRAP CATCH BASINS ARE SPECIFIED THE GAS TRAP IS TO BE INCLUDED IN THE BID PRICE OF THE STRUCTURE.

TYPICAL PRECAST CONCRETE CATCH BASIN (GAS TRAP TYPE SHOWN)

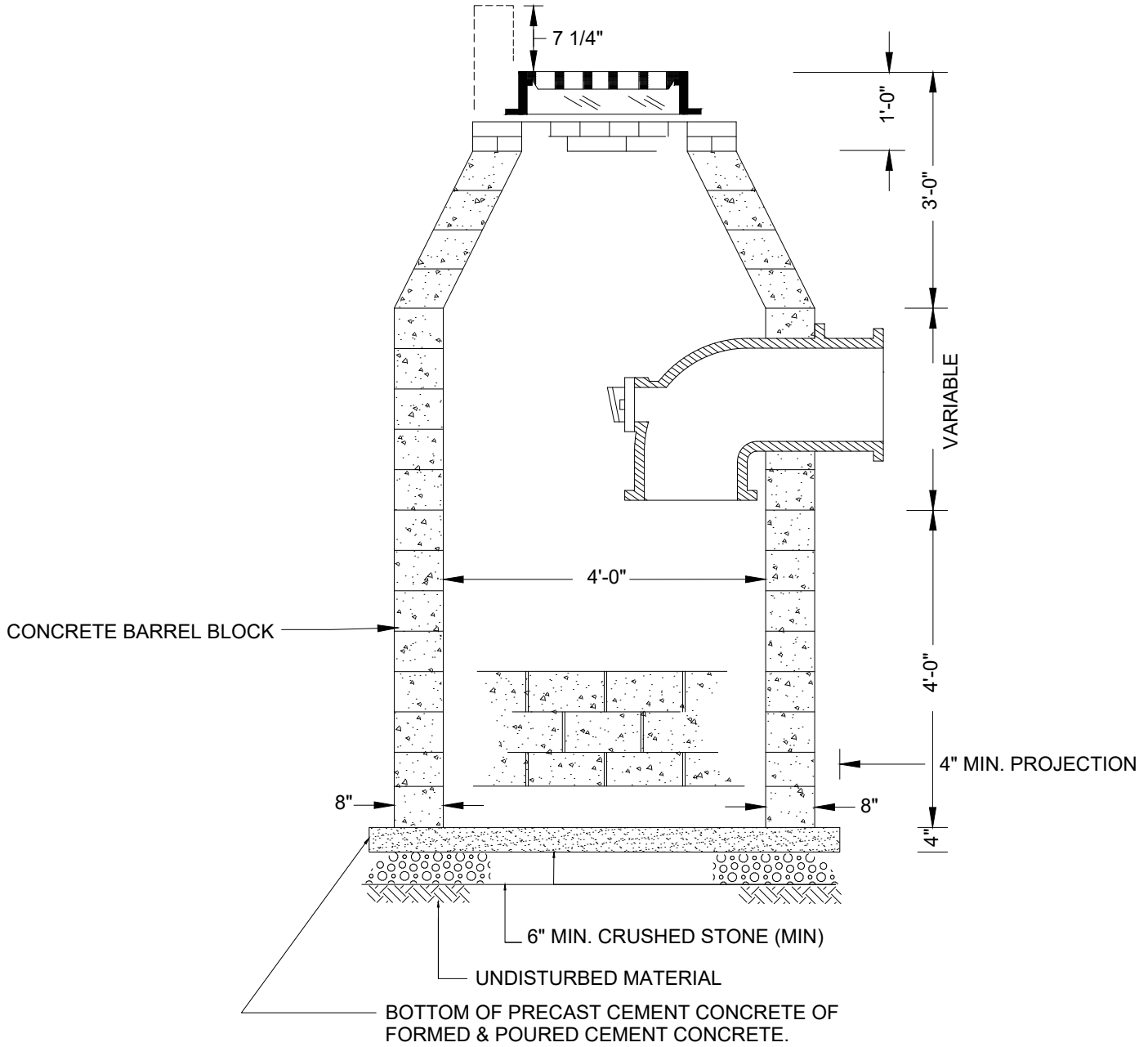

GAS TRAP: NEENAH R-3705 OR APPROVED EQUAL AND IS TO BE INCLUDED IN THE BID PRICE OF THE STRUCTURE.

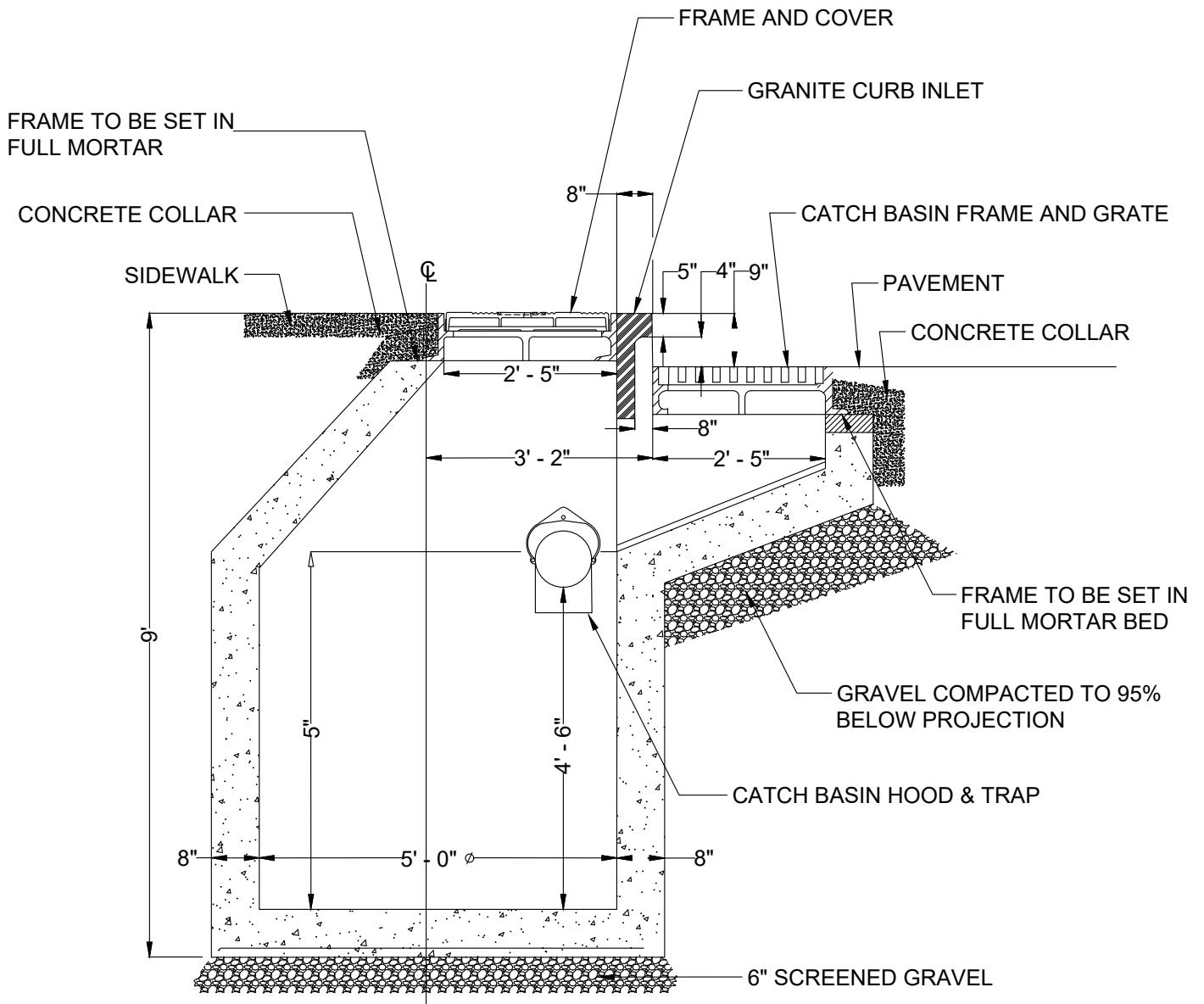

STANDARD CATCH BASIN DROP INLET (PIPE TO PIPE)

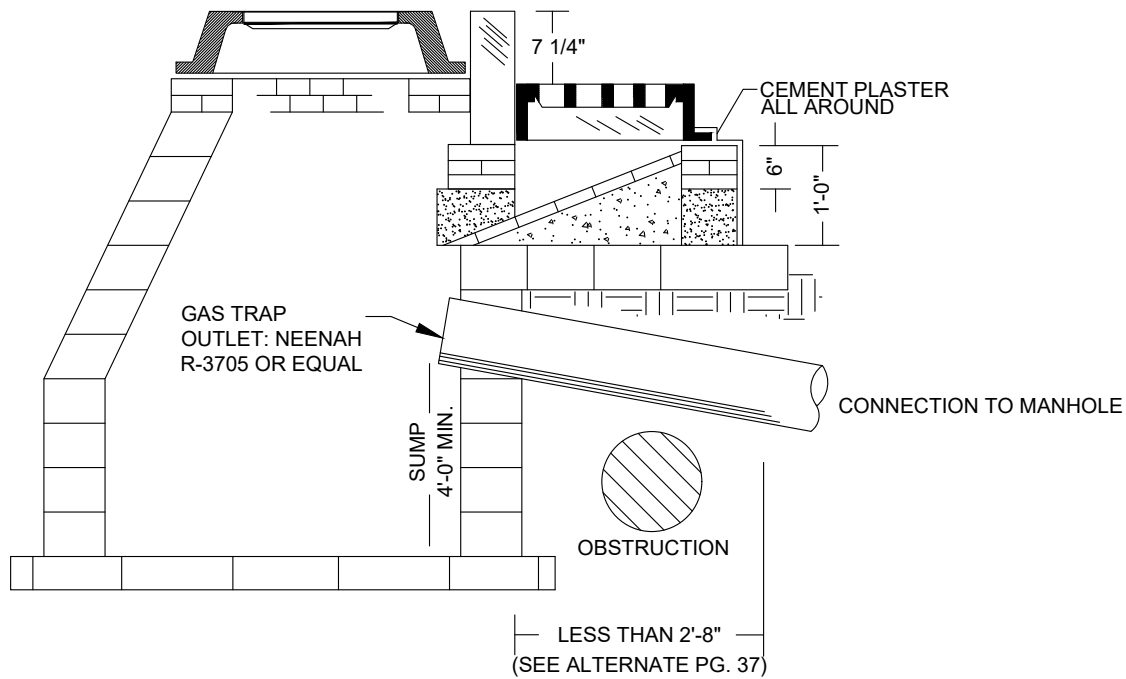
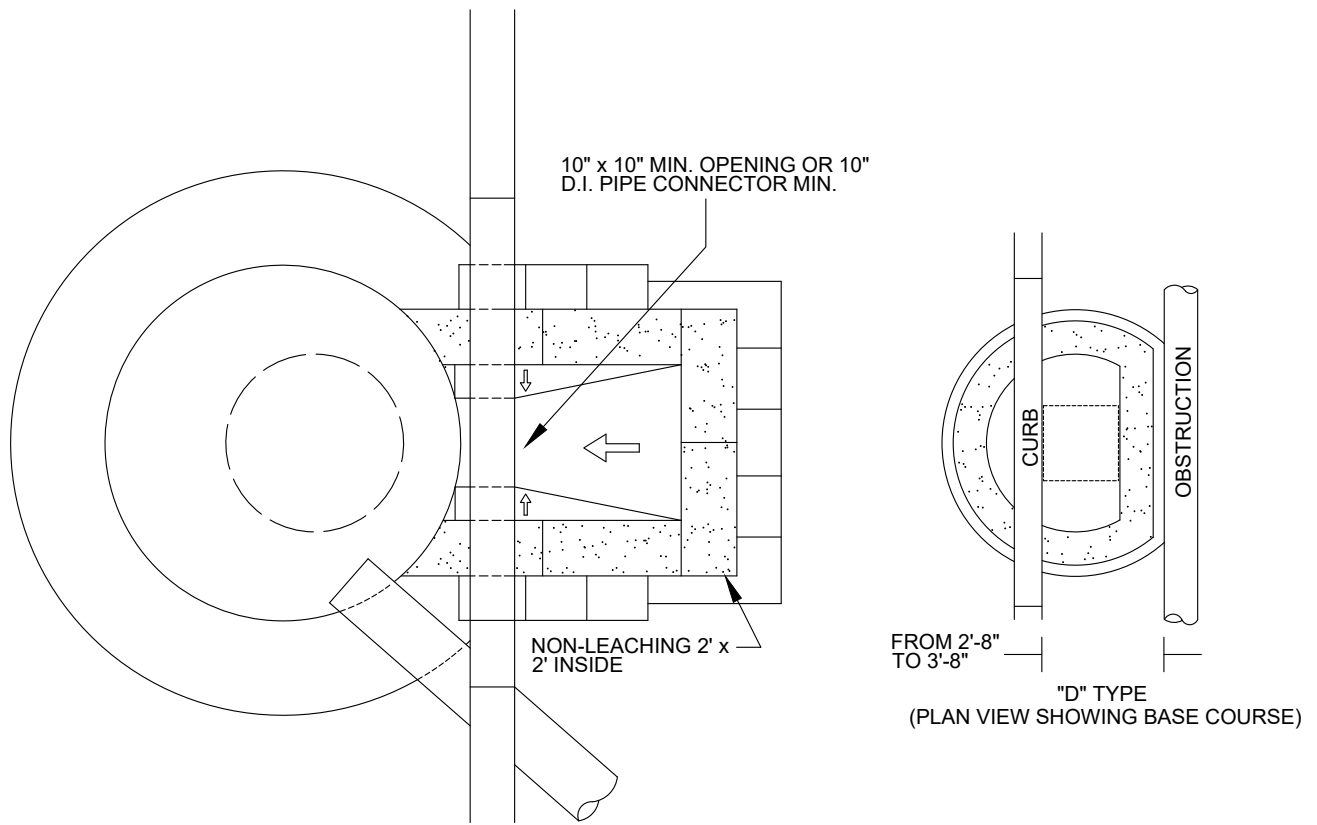

INLET	D	A	B	INLET	D	A	B
4"	3'-6"Ø	3'-0"	2'-6"	8"	5'-0"Ø	6'-0"	5'-0"
5"	3'-6"Ø	5'-0"	4'-0"		5'-6"x 5'-6"	4'-6"	4'-0"
	3'-6"x 3'-6"	4'-0"	3'-0"		6'-0"Ø	4'-0"	3'-6"
	4'-0"	3'-8"	3'-0"		6'-0"x 6'-0"	3'-0"	2'-6"
	4'-0"x 4'-0"	3'-0"	2'-6"	6'-6"Ø	3'-6"	3'-0"	
6"	4'-6"	3'-0"	2'-6"	6'-6"x 6'-6"	3'-0"	2'-6"	10"
	4'-0"Ø	5'-0"	4'-6"	5'-6"Ø	7'-6"	6'-6"	
	4'-0"x 4'-0"	4'-0"	3'-6"	6'-0"x 6'-0"	5'-6"	4'-6"	
	4'-6"Ø	4'-0"	3'-6"	6'-0"Ø	6'-6"	5'-6"	
	4'-6"x 4'-6"	3'-6"	3'-0"	6'-0"Ø	6'-6"	5'-6"	10"
	5'-0"Ø	3'-6"	3'-0"	6'-6"x 6'-6"	5'-0"	4'-0"	
	5'-0"x 5'-0"	3'-0"	2'-6"				

**NOTES:**

- FOR INLETS LARGER THAN 10" THE DESIGN AND DIMENSIONS WILL BE DETERMINED FOR EACH PARTICULAR CASE
- PRE-CAST SEPARATORS ARE TO HAVE ALL SPECIFIED HOLES EITHER CORE-BORED OR CAST IN PLACE

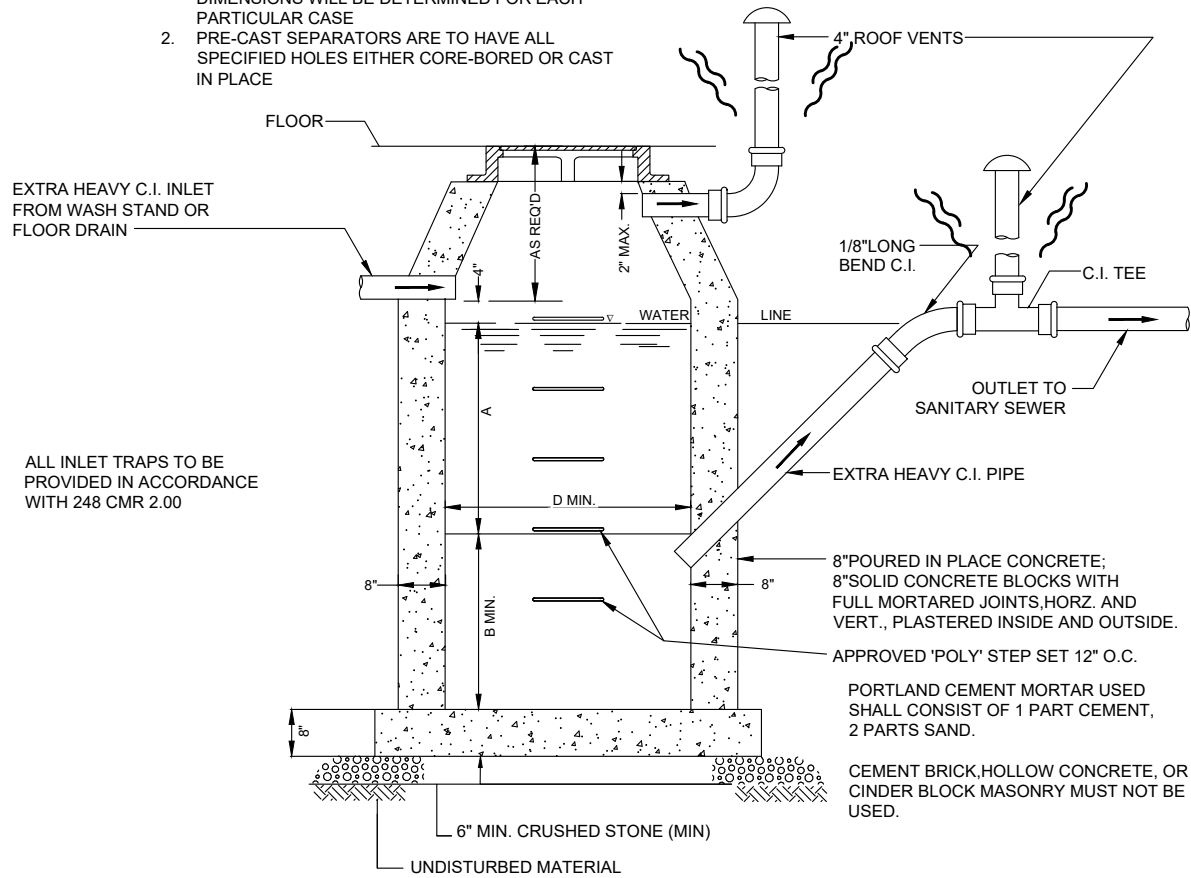

ALL INLET TRAPS TO BE PROVIDED IN ACCORDANCE WITH 248 CMR 2.00

**GENERAL CONSTRUCTION NOTES**

BASIN TO BE LOCATED OUTSIDE OF BUILDING WHERE POSSIBLE, COVER TO HAVE A CENTER HOLE.

A TIGHT COVER MUST BE USED IF BASIN IS LOCATED INSIDE OF BUILDING.

OPENING SHALL BE NOT LESS THAN 24" DIA.

THE CATCH BASIN SHALL BE SO LOCATED AND CONSTRUCTED THAT SURFACE WATER SHALL BE EXCLUDED.

INLET PIPE SHALL BE AT LEAST FOUR INCHES ABOVE NORMAL WATER LINE.

WHERE SUBJECT TO FROST OR CRUSHING CONDITIONS, OUTLET SHALL BE AT LEAST THREE FEET BELOW THE SURFACE.

THE NEW CATCH BASIN MUST BE FILLED WITH CLEAN WATER BEFORE USING, AND AFTER BEING EMPTIED FOR PERIODIC CLEANING.

ALL OIL AND GASOLINE MUST BE REMOVED BEFORE CLEANING OUT THE BASIN, AND MUST NOT BE DISCHARGED INTO THE SEWER THROUGH OTHER FIXTURES.

SPECIFICATIONS FOR COVERING SPECIAL CASES OR CONDITIONS, SHALL BE APPROVED BY THE LOCAL AUTHORITIES, AND THE AUTHORITIES OF THE M.W.R.A.

WROUGHT IRON STEPS SHALL BE SPACED ABOUT 18" APART.

BOTH VENTS SHALL BE EXTENDED INDEPENDENTLY 18" ABOVE THE ROOF, OR AS APPROVED BY THE LOCAL AUTHORITIES, AND THE AUTHORITIES OF THE M.W.R.A.

OUTLET PIPE TO BE 45 DEGREE ANGLE.

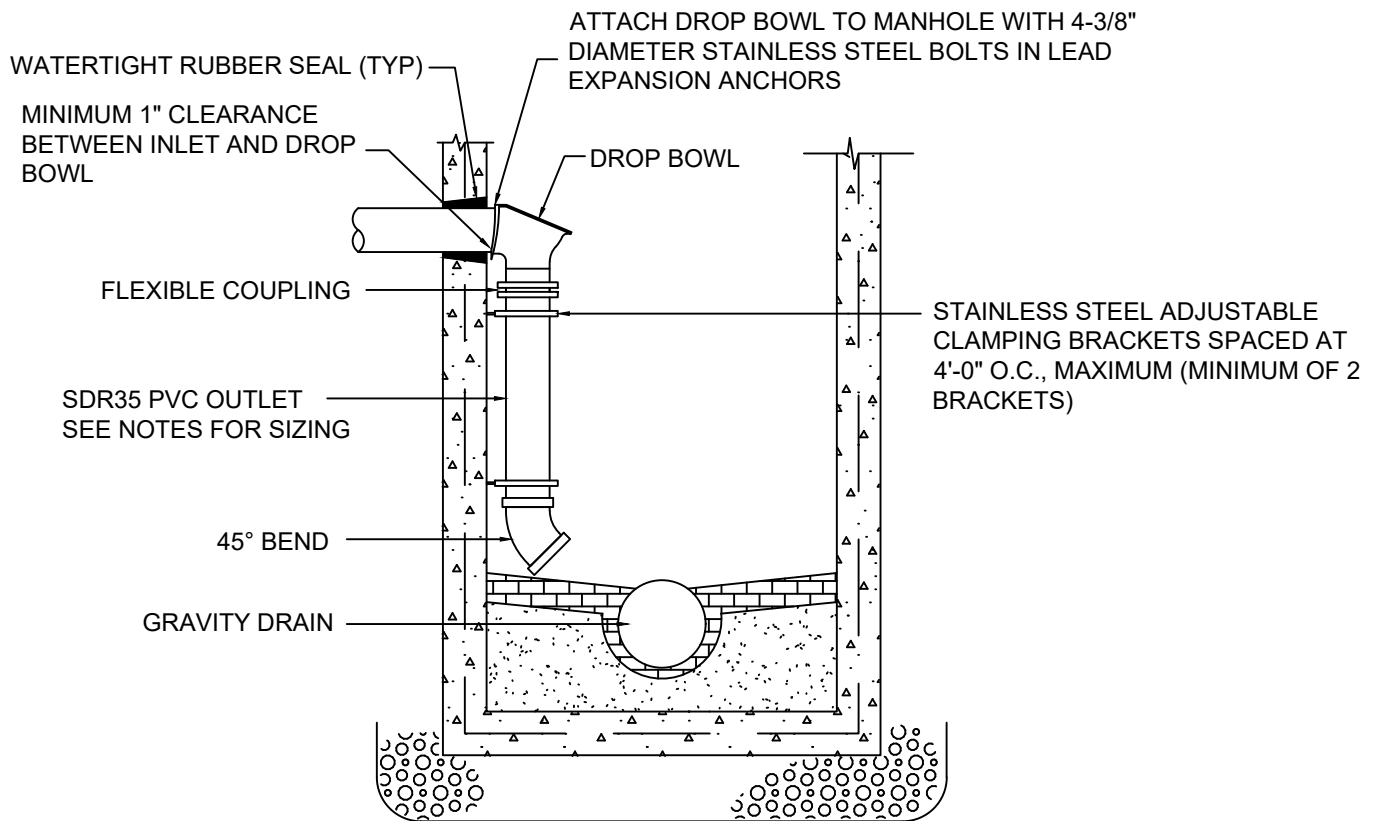

- NOTES:**
- USE 4" OUTLET FOR UP TO 6" INLET
  - USE 6" OUTLET FOR UP TO 8" INLET
  - USE 8" OUTLET FOR UP TO 10" INLET

# BLEEDER DRAIN

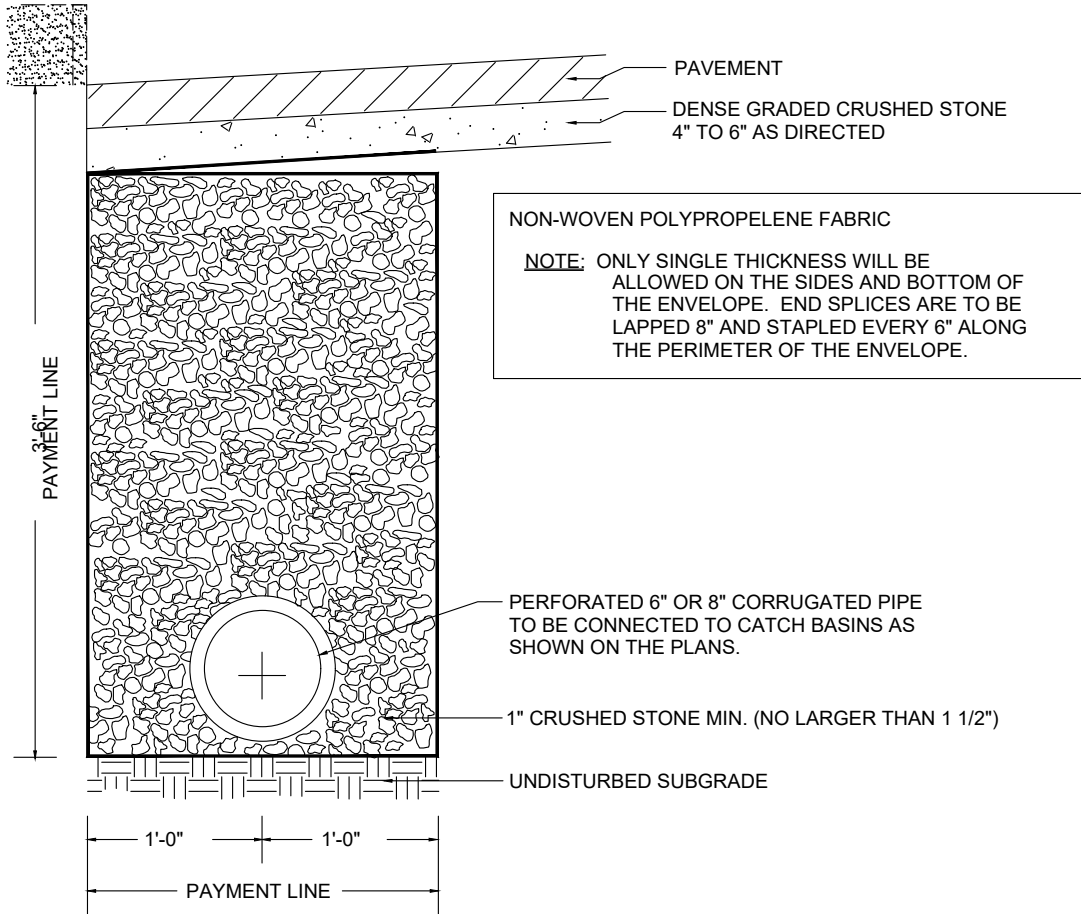

BLEEDER PIPE IS TO BE CONNECTED TO CATCH BASINS AND/OR MANHOLES ON THE "UPHILL" SIDE ONLY AND AT A LEVEL NO LOWER THAN THE UNIT

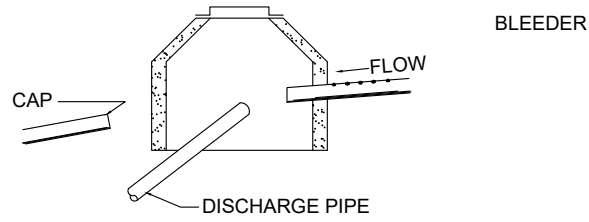



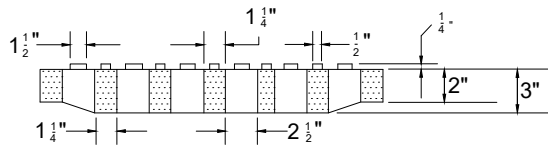
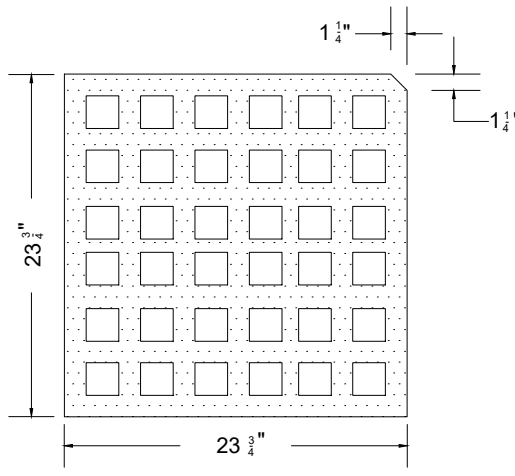

AUXILIARY FLANGE WHEN NO CURB IS PRESENT

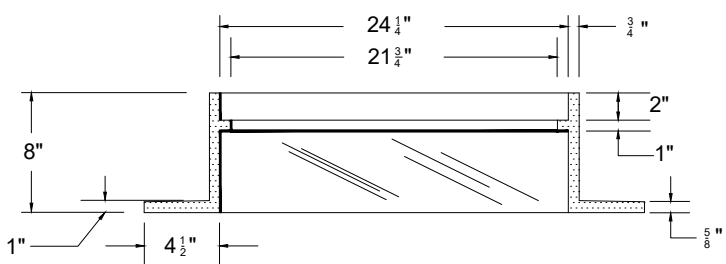
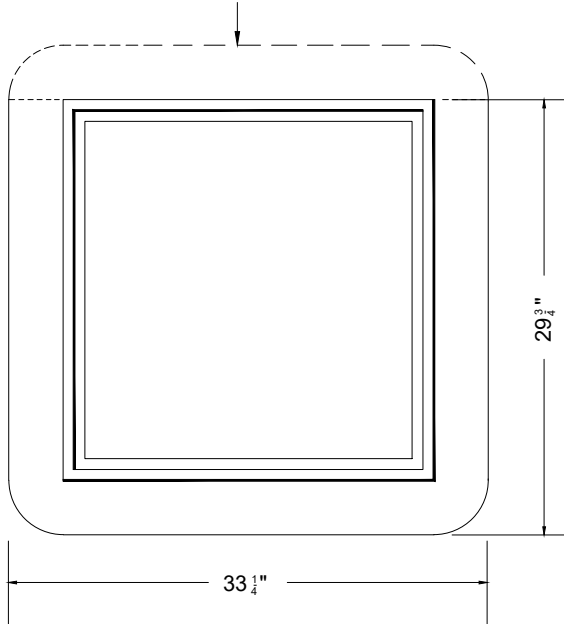

NOTES: MINIMUM WEIGHT OF GRATE AND FRAME - 480 lbs.

NORTH AMERICAN STEEL ONLY

ALL FRAMES AND COVERS SHALL MEET OR EXCEED H20 LOADING

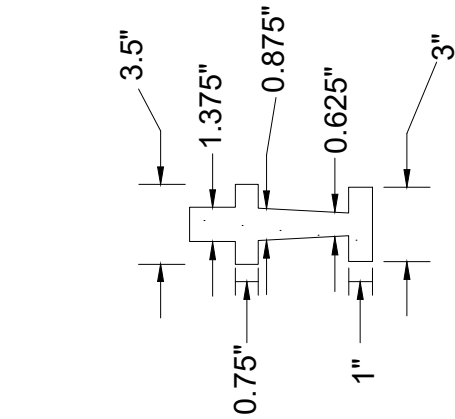

SECTION B-B

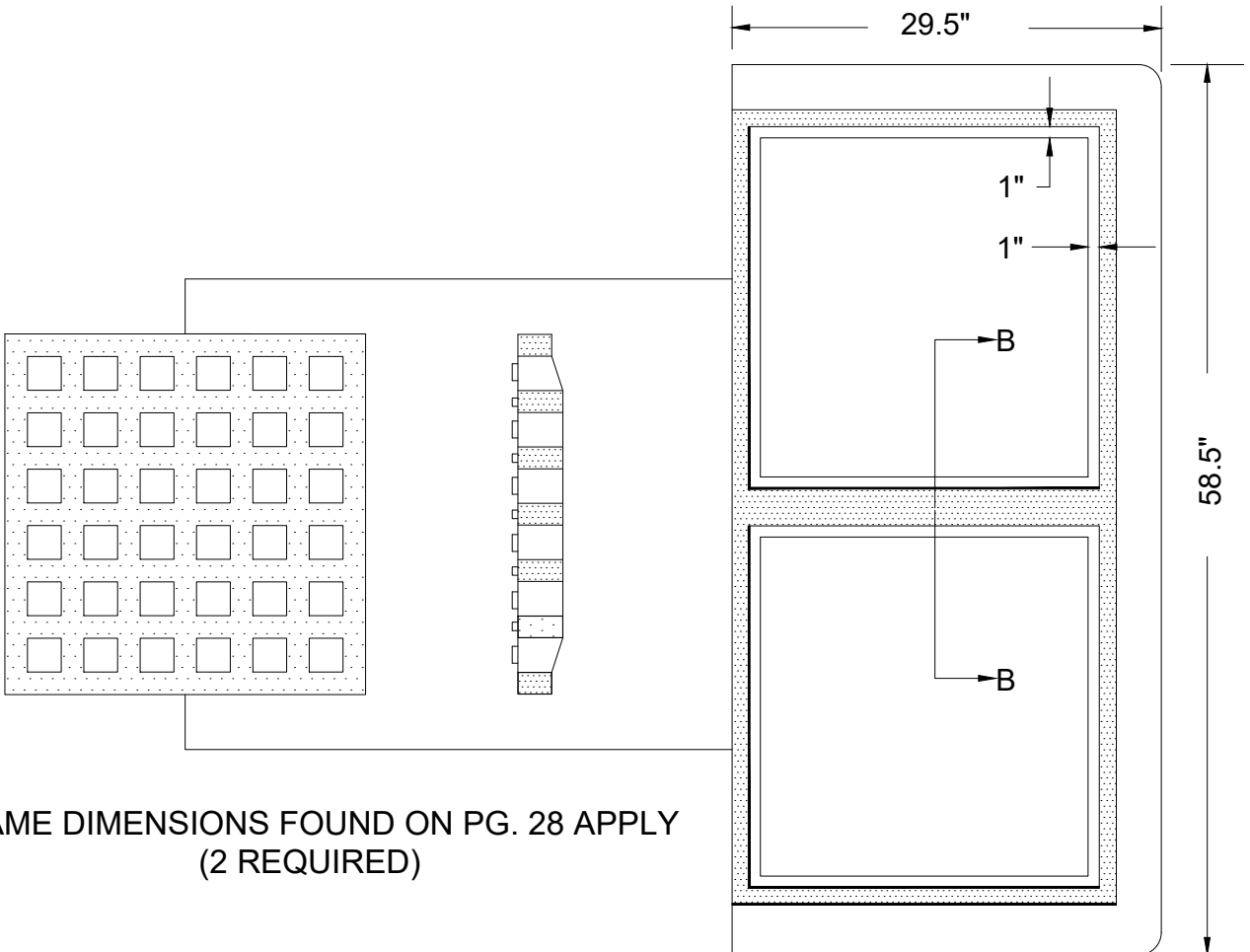
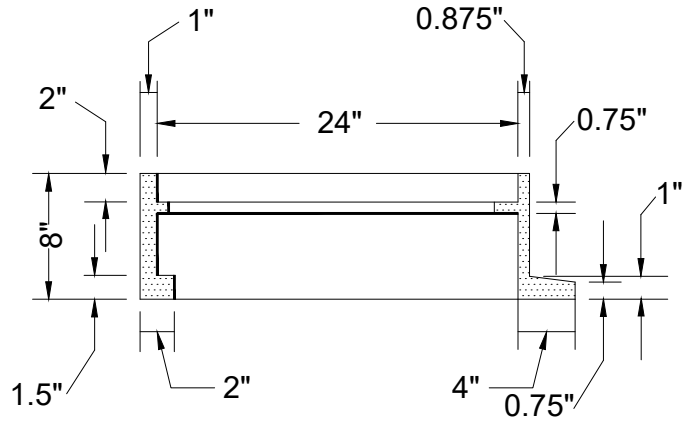

FRAME DIMENSIONS FOUND ON PG. 28 APPLY  
(2 REQUIRED)

NOTES: MINIMUM WEIGHT OF GRATE AND FRAME - 480 lbs.

NORTH AMERICAN STEEL ONLY

ALL FRAMES AND COVERS SHALL MEET OR  
EXCEED H20 LOADING

TOP

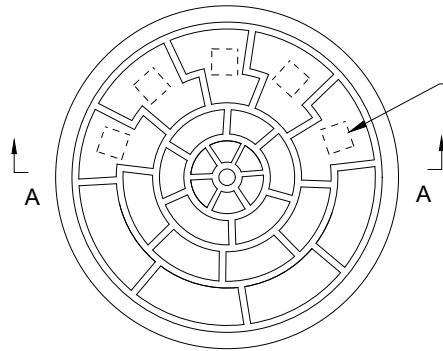

**NOTE:** TO BE CAST IN PLACE  
D-R-A-I-N  
S-E-W-E-R  
W-A-T-E-R  
(3" LETTERS)

BOTTOM

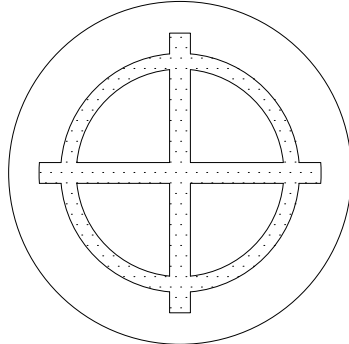

**NOTE:** COVERS ARE TO BE SUPPLIED WITHOUT HOLES

SIDE

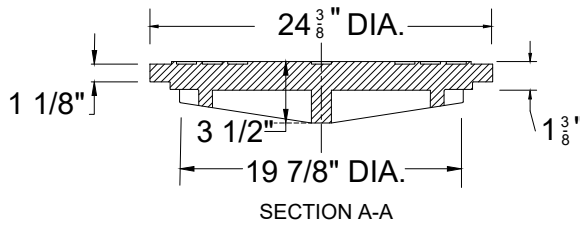

**NOTE:** MADE IN USA  
2225A  
ASTM A48 CL35B  
PROD NO.  
MO/DY/YR X

MINIMUM WEIGHT OF COVER: 230 lbs.

TOP

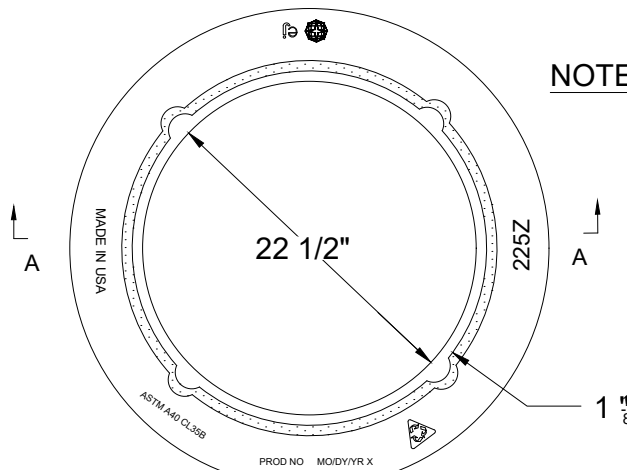

**NOTE:** CASTINGS ARE TO BE NORTH AMERICAN STEEL ONLY

SHALL MEET OR EXCEED H20 LOADING

SIDE

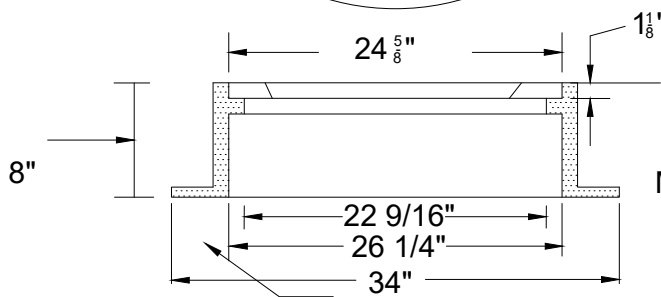

MINIMUM WEIGHT OF FRAME: 250 lbs.

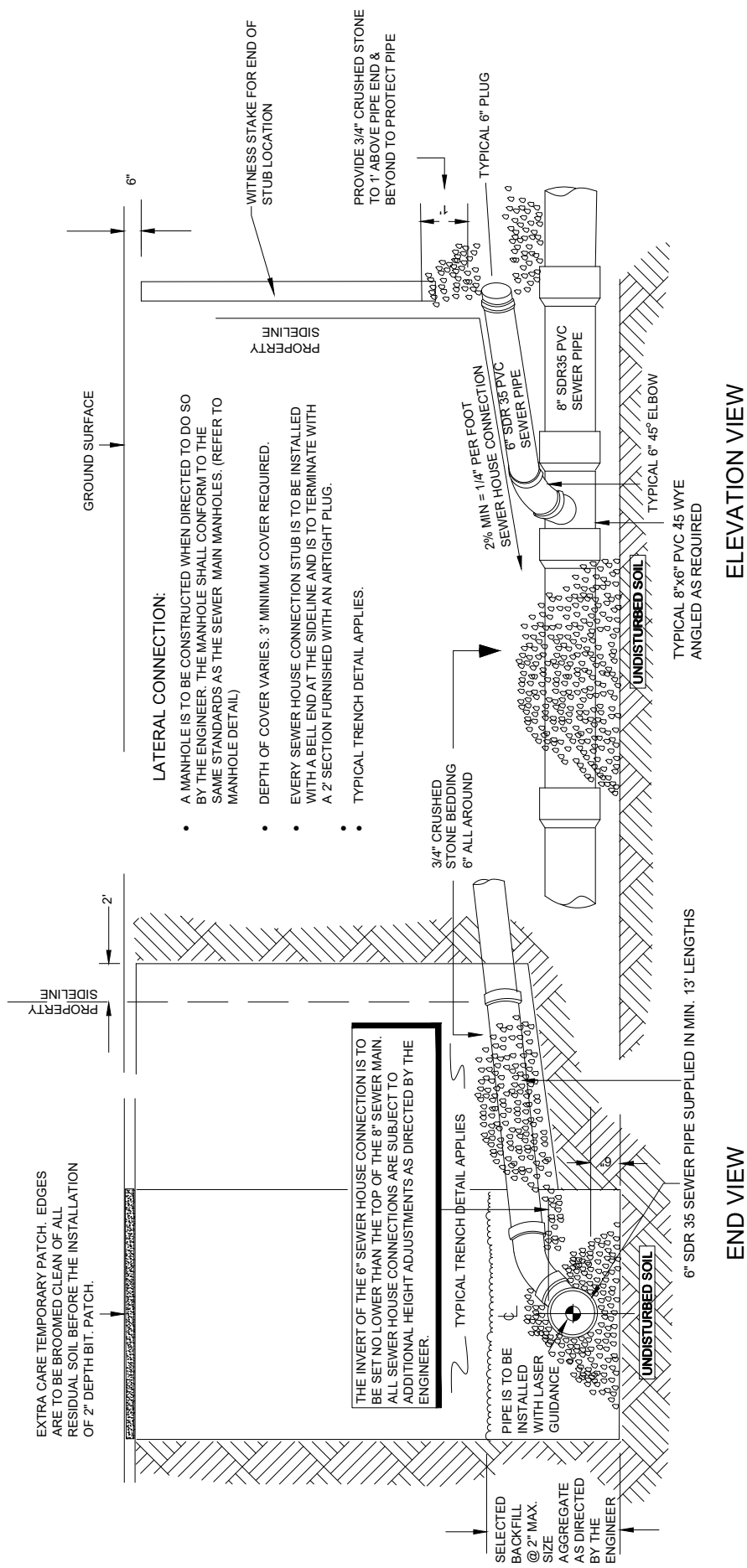

ELEVATION VIEW

END VIEW

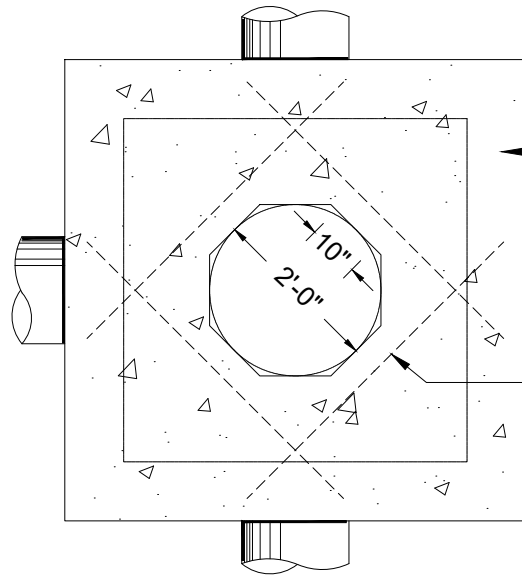

4000 PSI CEMENT CONCRETE

4-#5 REINFORCING BARS  
DIAGONALLY SET  
(SEE BELOW)

BRANCH  
LINE

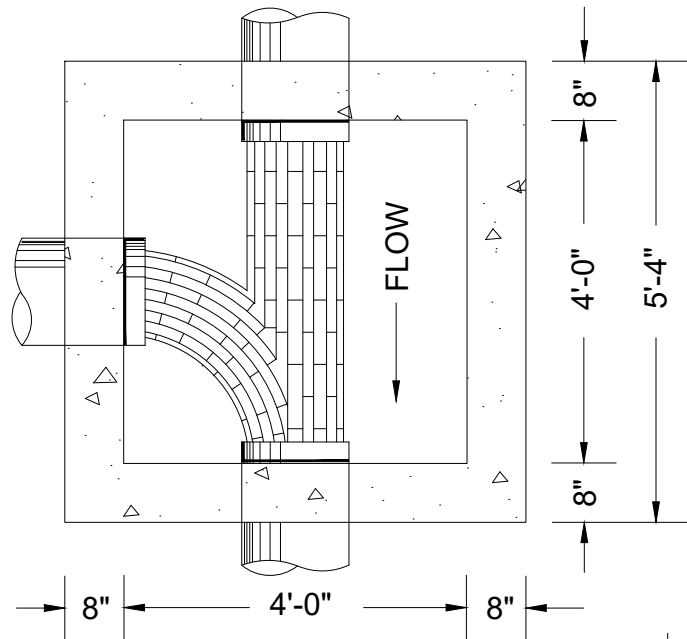

#5 REINFORCING  
BARS  
8" O.C.  
BOTH WAYS

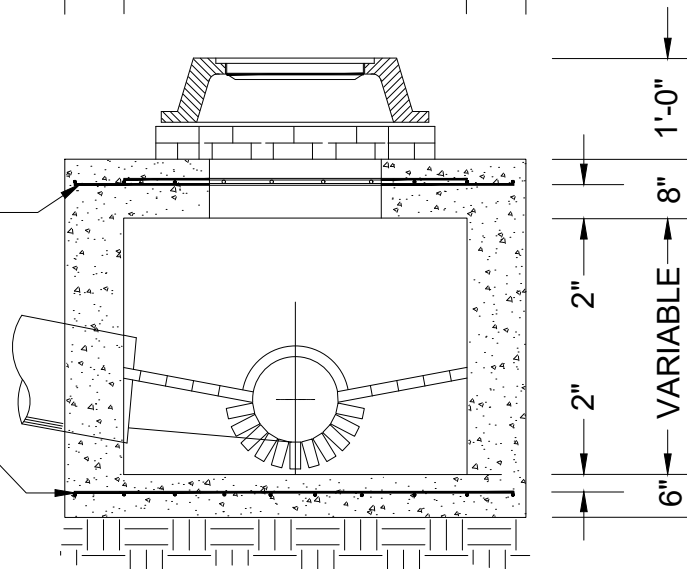

HEADER COURSE EVERY SEVENTH COURSE.  
MANHOLE STEP EVERY FIFTH COURSE FROM TABLE.

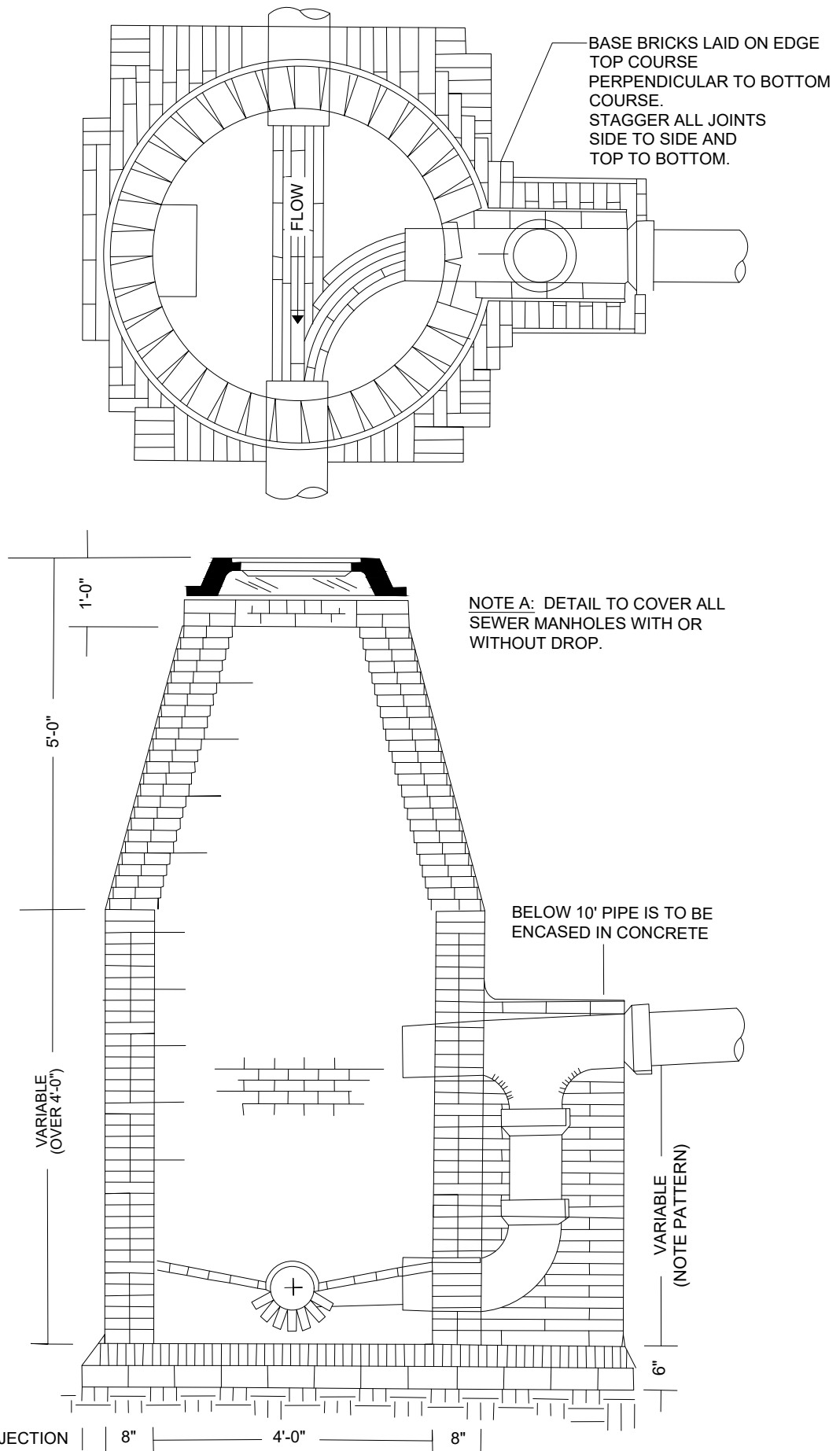

HEADER EVERY SEVENTH COURSE  
 MANHOLE STEP EVERY FIFTH COURSE FROM TABLE

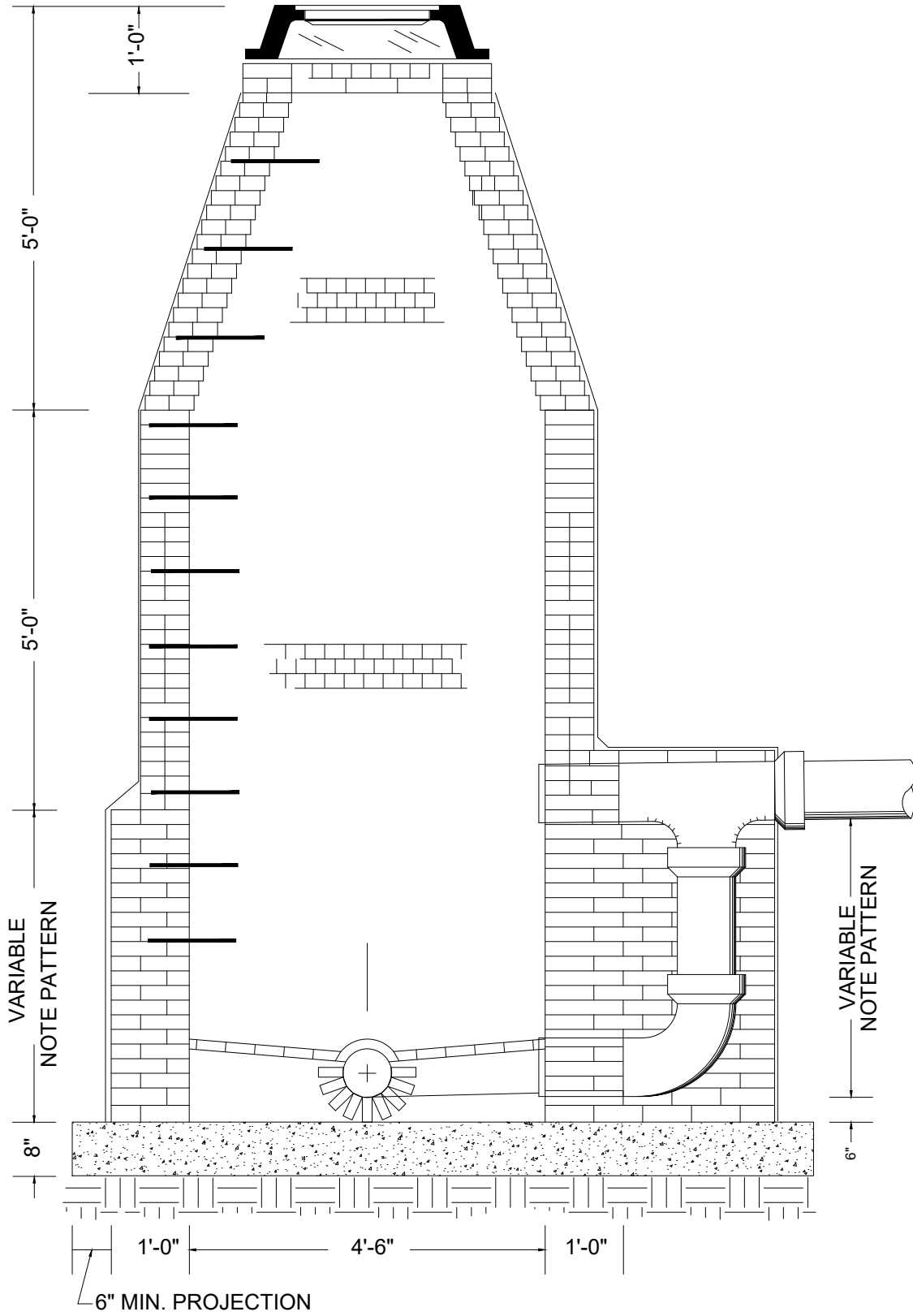

SPECIAL SEWER MANHOLE - DEPTH 10'+ (EXISTING CONSTRUCTION)

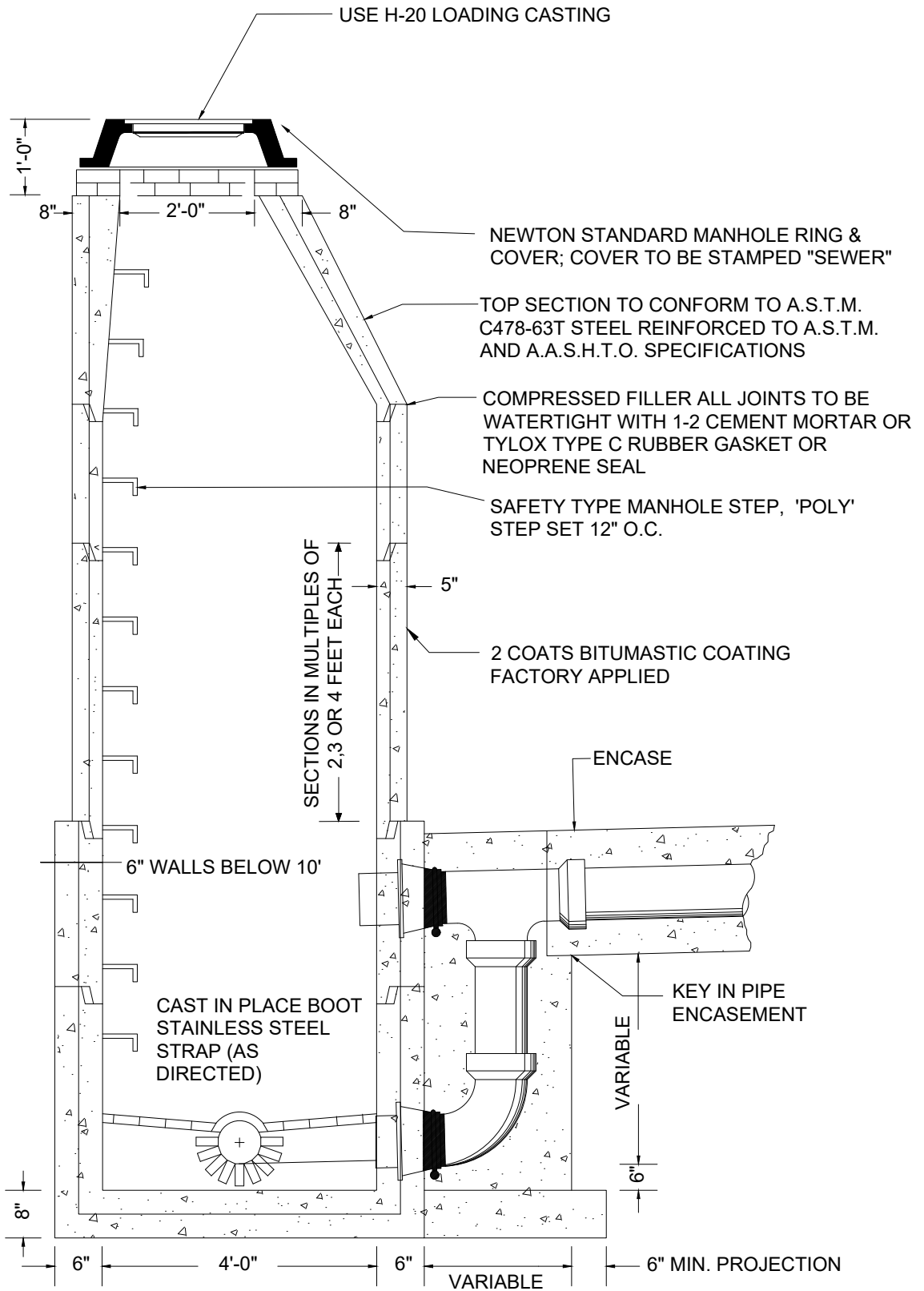

8" AUXILIARY FLANGE INTEGRALLY CASE (IF DEPTH EXCEEDS 9')

OPENINGS ARE TO BE MANUFACTURED INTO THE STRUCTURE



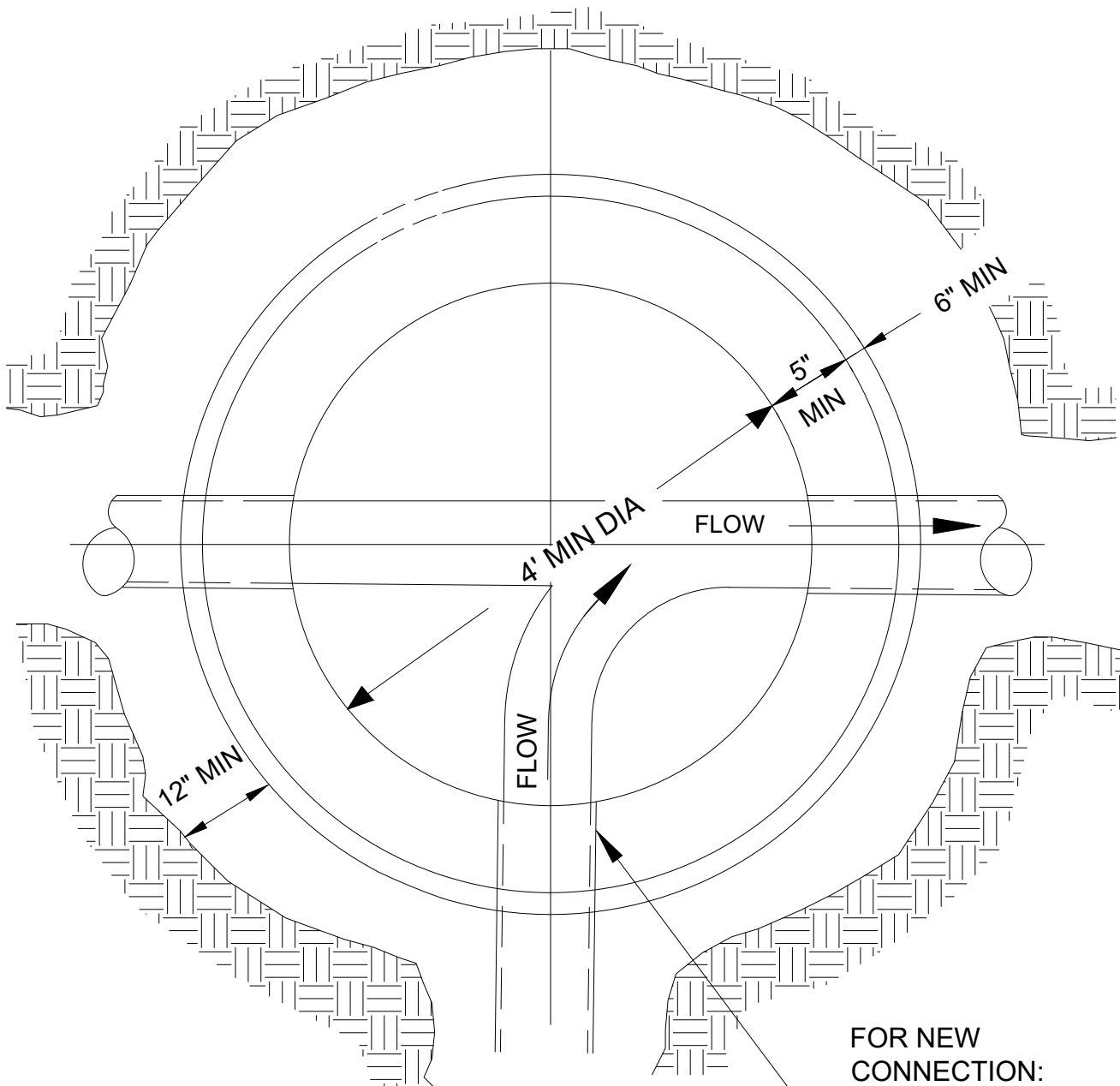

INVERT OF LATERAL IS  
SPRINGLINE OF MAIN

FOR NEW  
CONNECTION:  
NO JACK-HAMMERING  
CORE BY MECHANICAL  
MEANS

TOP VIEW

INTERIOR DROPS ARE TO BE USED ONLY BY APPROVAL

NO JACK-HAMMERING  
MECHANICAL CORE ONLY

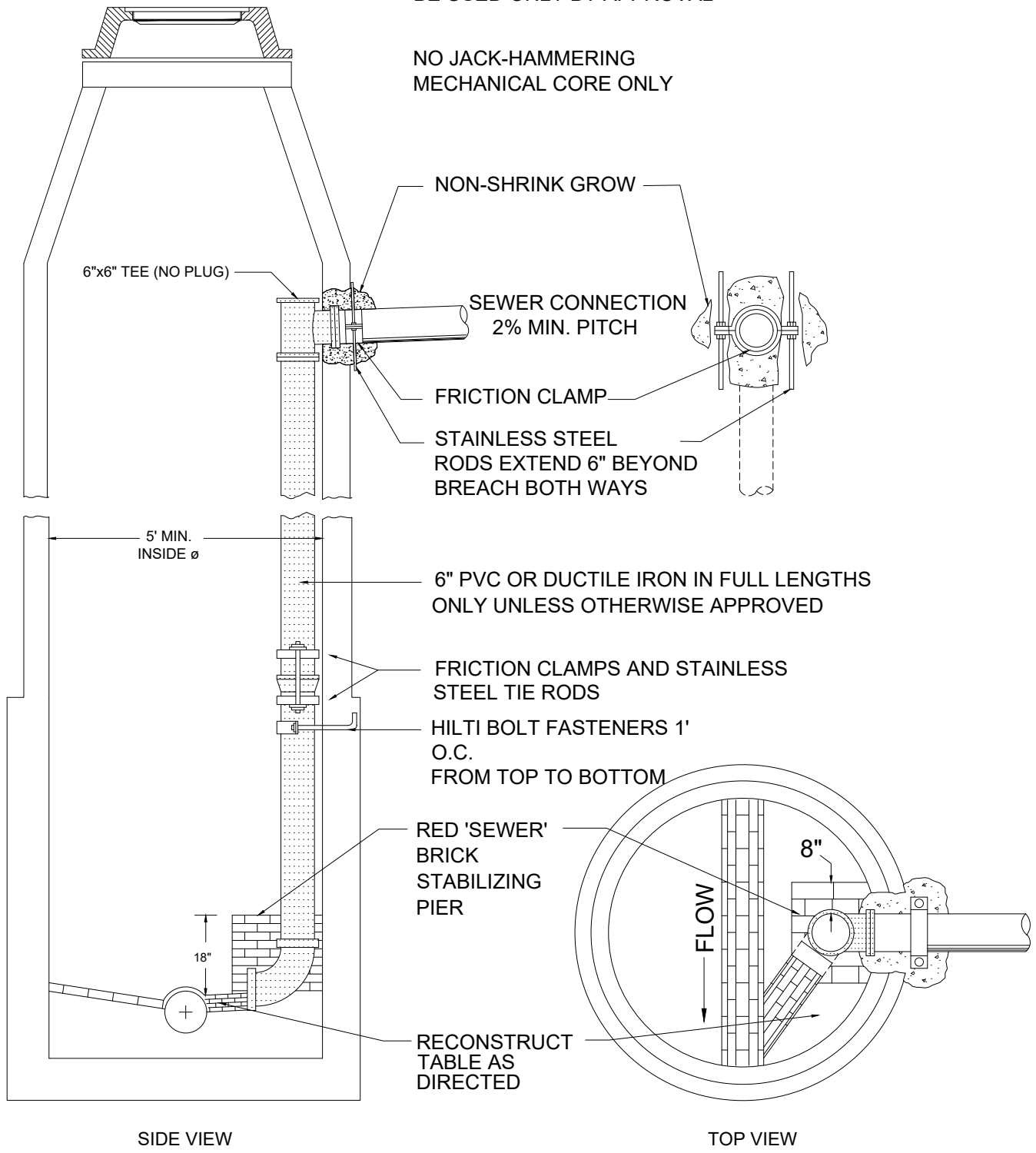

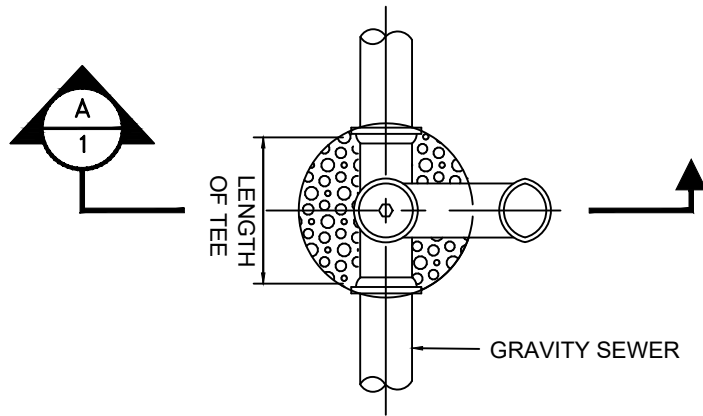

PLAN VIEW

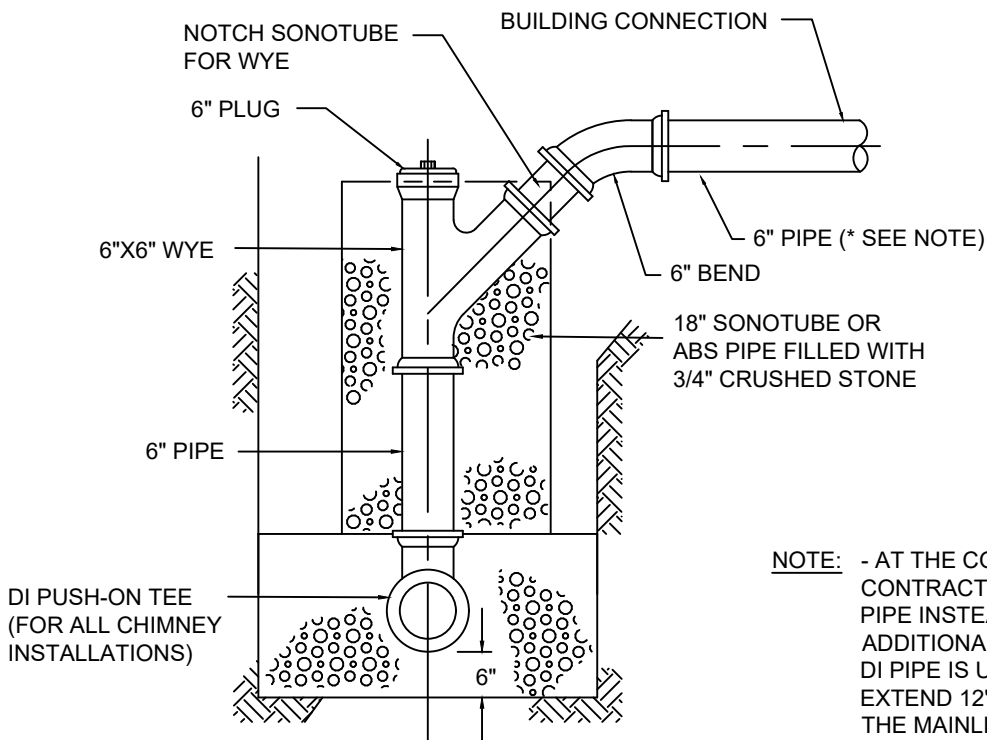

**NOTE:** - AT THE CONTRACTORS OPTION, THE CONTRACTOR MAY ELECT TO USE DI PIPE INSTEAD OF PVC AT NO ADDITIONAL COST TO THE OWNER. IF DI PIPE IS USED, THE DI PIPE SHALL EXTEND 12" BEYOND THE EDGE OF THE MAINLINE TRENCH AND BE FITTED WITH A PVC ADAPTER.

TOP VIEW

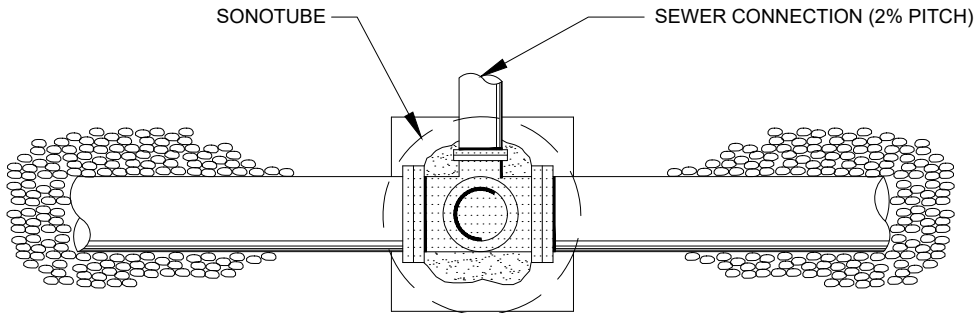

SURFACE - - - - -  
VARIES

NOTE: ANY PVC PIPE WITH LESS THAN 30" OF COVER MUST BE ENCASED.

PVC TEE AND PLUG

VARIABLE HEIGHTS  
SINGLE LENGTHS ONLY  
(TYPE AND SIZE MUST BE PRE-APPROVED  
BY THE CITY OF NEWTON)

3-4' HIGH SONOTUBE  
W/ CONCRETE FOR  
STABILITY

3/4"-1" CRUSHED STONE MIN. 6"  
ABOVE AND BELOW PIPE

USE PROPER PVC TO DI RUBBER  
WHEN A PVC CHIMNEY  
ASSEMBLY IS INSTALLED ON A  
PVC TRUNKLINE

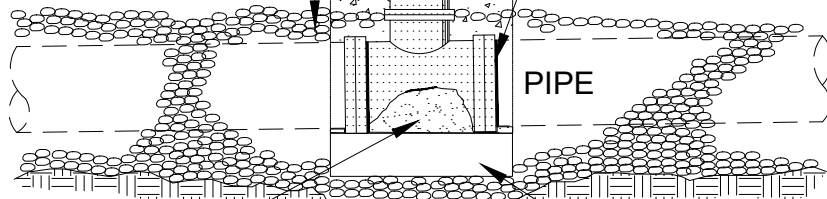

8"

2'x2'x8" 4000 LB. PRECAST CONCRETE

FIRE HYDRANTS = -MUELLER SUPER CENTURION 200  
 -AMERICAN DARLING B-84-B-5  
 -KENNEDY GUARDIAN K81D

ALL HYDRANTS MUST: BE FACTORY PAINTED RED WITH A WHITE  
 BONNET

OPEN RIGHT

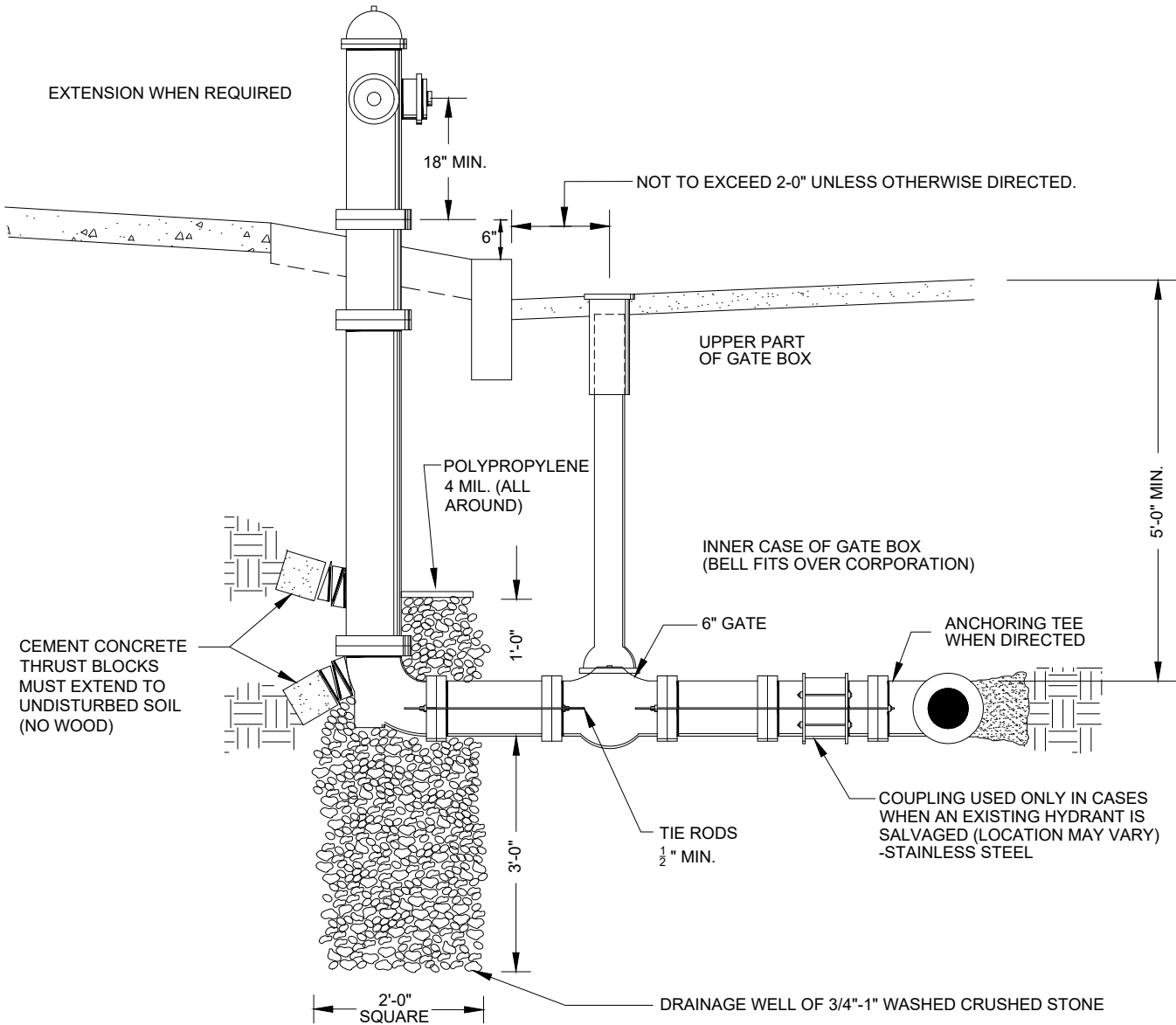

CEMENT CONCRETE  
 THRUST BLOCKS  
 MUST EXTEND TO  
 UNDISTURBED SOIL  
 (NO WOOD)

NOTE:  
 MEGALUGS AT ALL JOINTS

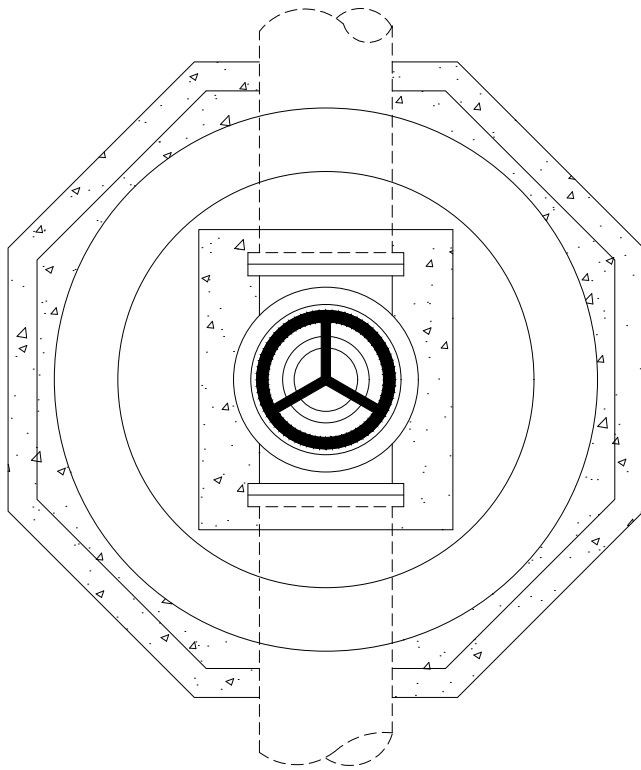

HEADER EVERY SEVENTH COURSE  
 MANHOLE STEPS EVERY FIFTH COURSE FROM BOTTOM.  
 NOTE: PRECAST CONCRETE WITH FLAT TOP

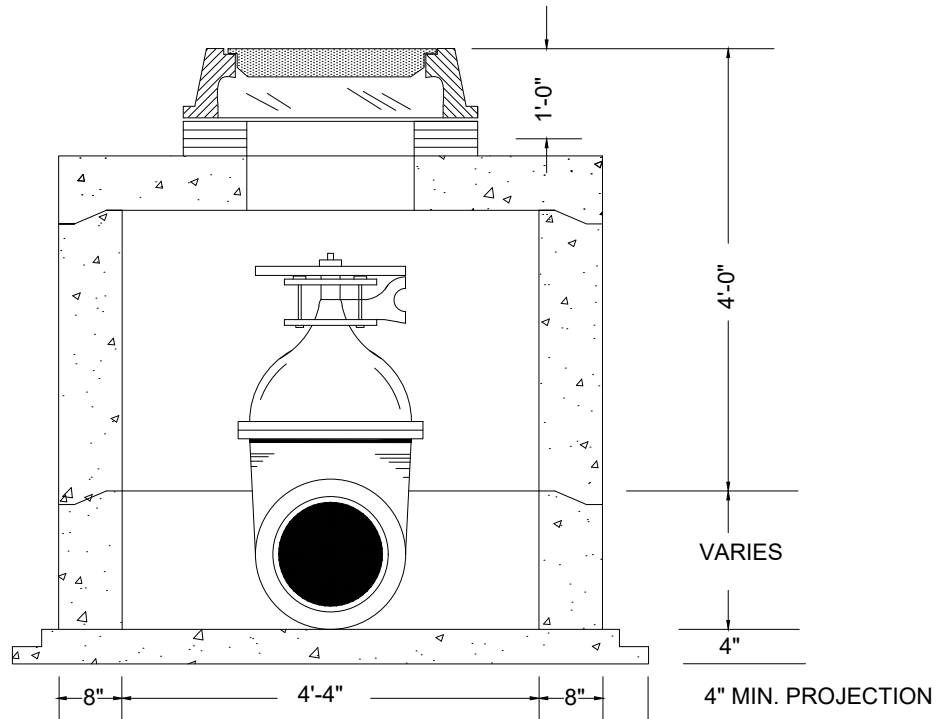

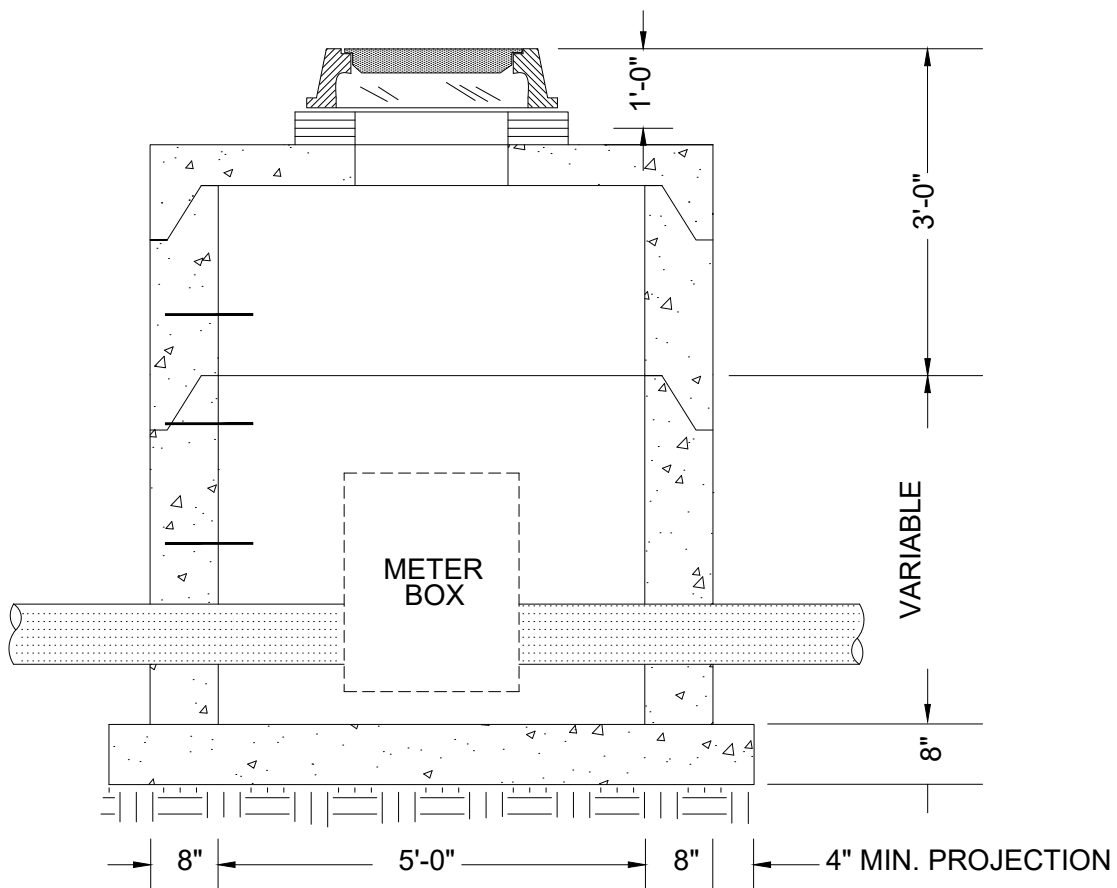
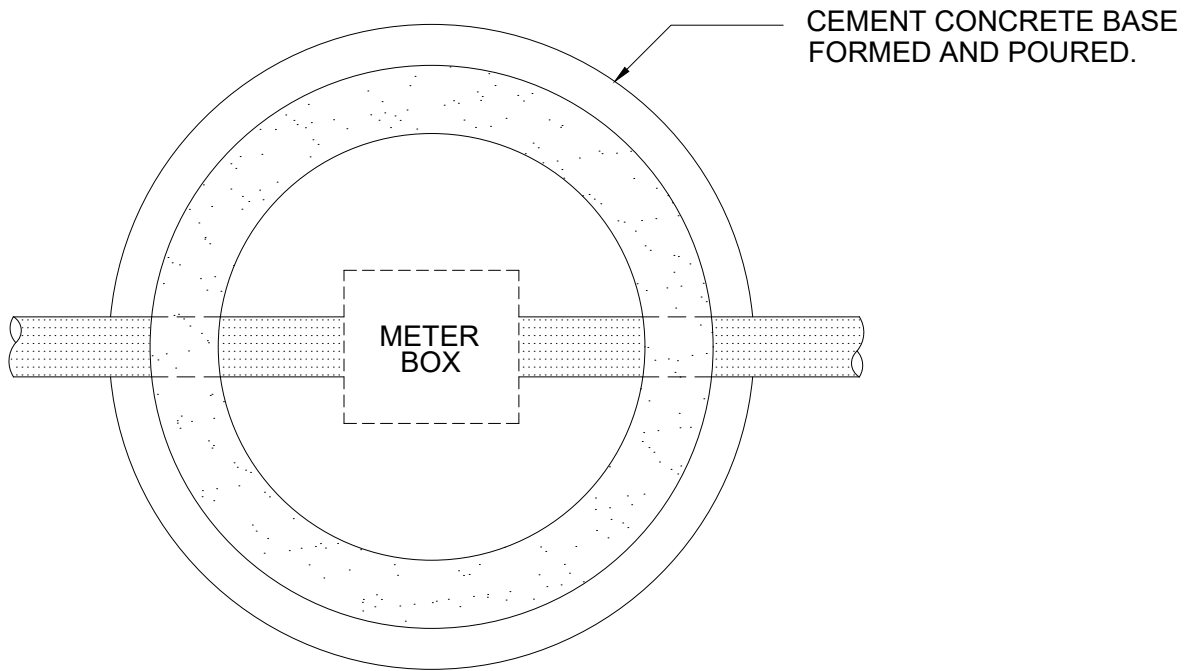

MANHOLE STEPS EVERY TWO COURSE FROM BOTTOM.  
 CEMENT CONCRETE BLOCK AS APPROVED. PRECAST CONCRETE SHOWN.

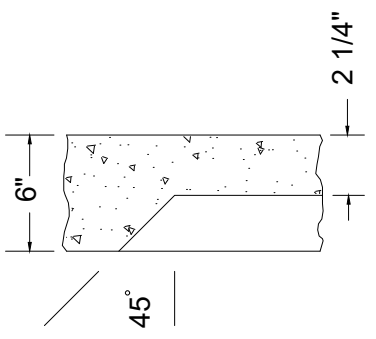

**KNOCKOUT**

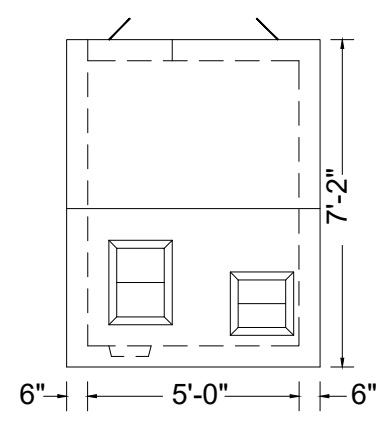

6" 5'-0" 7'-2" 6"

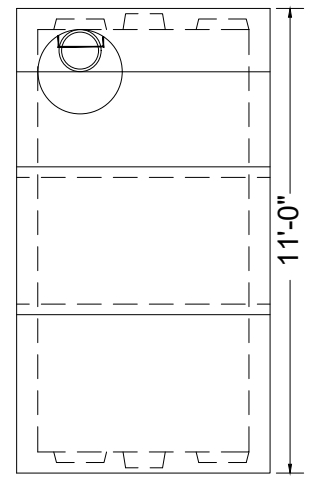

11'-0"

5000 LB. CEMENT CONCRETE  
TOTAL WEIGHT 21,800 LBS.

REINFORCEMENT: STEEL: GRADE 40 MIN. COVER 1" ASTM A-615 68 (NONE IN KNOCKOUT AREA)

LOADING: CONFORM TO AASHO-HS20-40

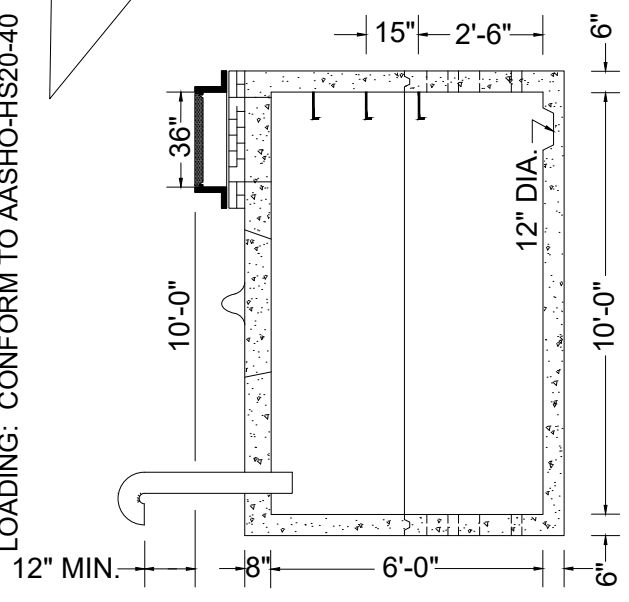

12" MIN. 8" 6'-0" 6" 10'-0" 10'-0" 6" 15" 2'-6" 36" 12" DIA.

4" I.D. VENT PIPE OF SCHED. 40 PVC, BLACK IRON OR OTHER APPROVED MATERIAL. LOCATED AT THE END OF THE CHAMBER IT IS TO BE SECURELY FASTENED TO THE STRUCTURE AND MADE WATERTIGHT.

PIPE INSTALLED AS DIRECTED

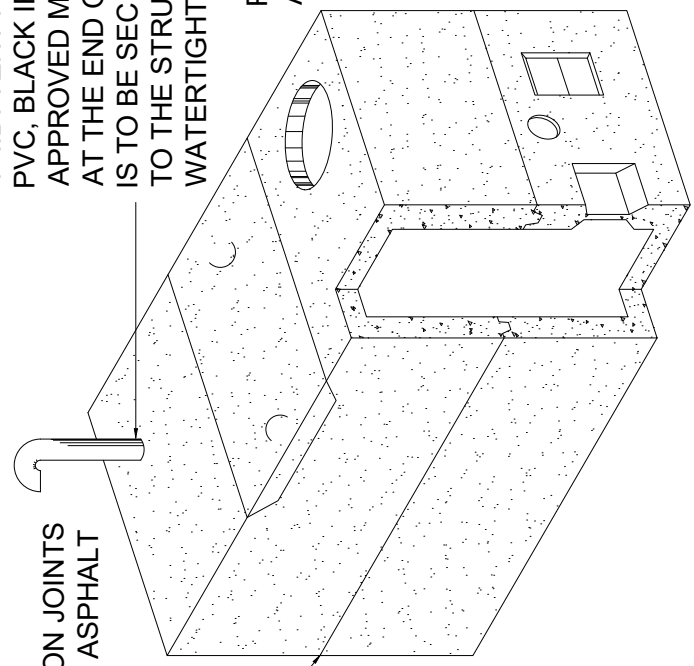

CONSTRUCTION JOINTS SEALED WITH ASPHALT CEMENT.



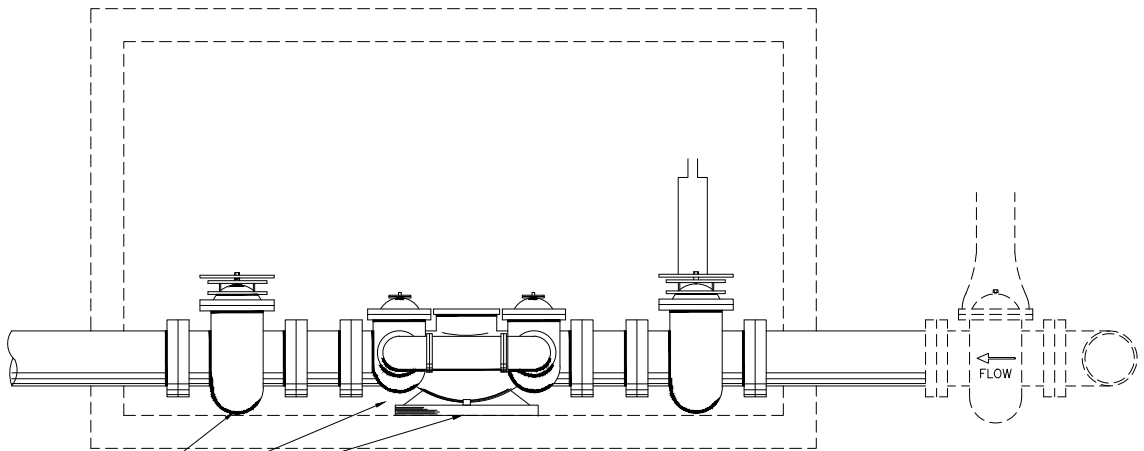

BLOCKING/SHIMS/BASEPLATES AS REQUIRED

SIDE VIEW

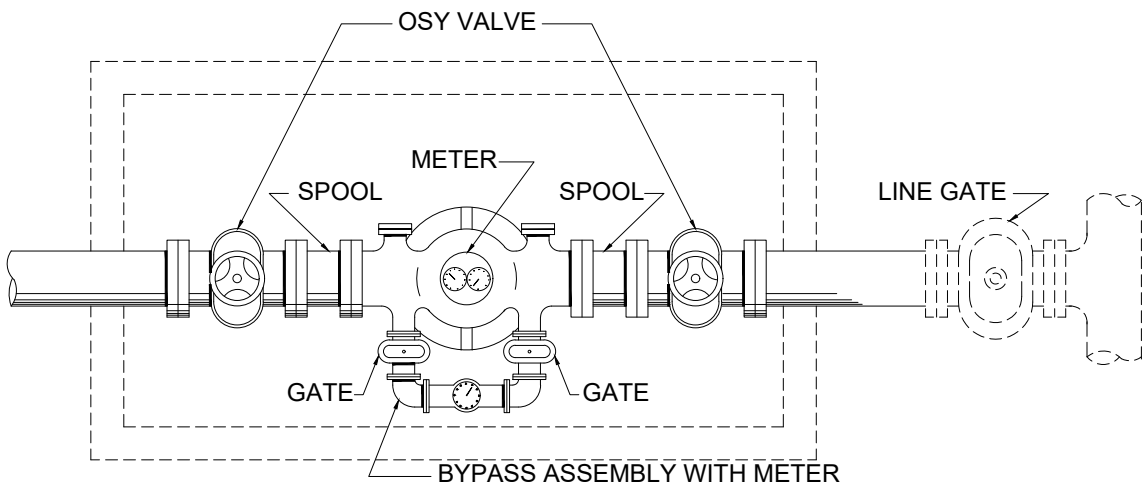

TOP VIEW

PRECAST CONCRETE METER PIT:  
 ALL VALVES OPEN RIGHT  
 ALL COMPONENTS AND INSTALLATION SUBJECT TO THE APPROVAL OF THE CITY OF NEWTON

NOTE A: KEEP THRUST BLOCKS SEPARATED BY A MINIMUM OF 6"

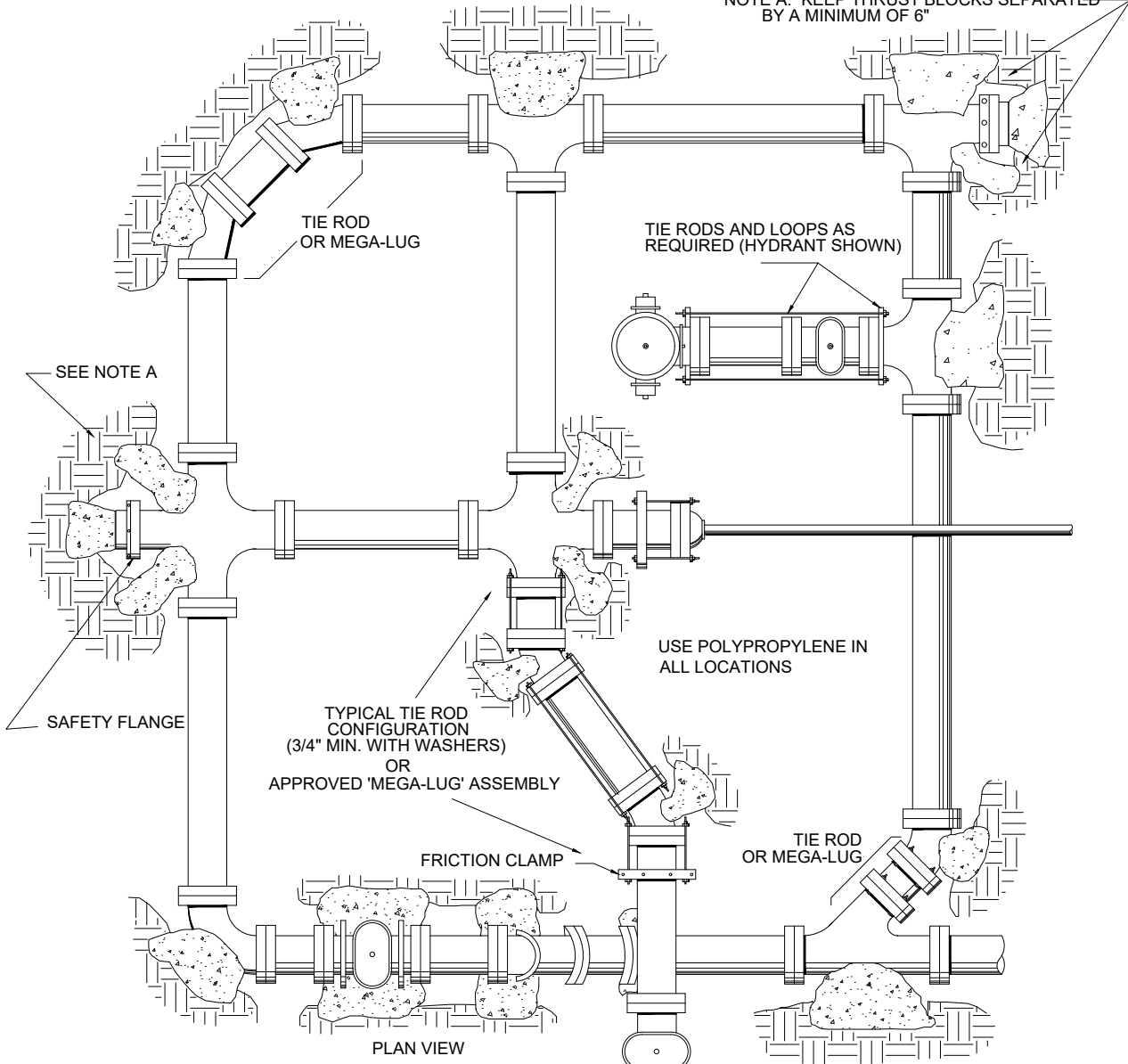

PLAN VIEW

THRUST BLOCKS ARE TO BE OF CLASS B CONCRETE OR OTHER APPROVED MEANS, OF SUFFICIENT SIZE AS APPROVED AND SHALL EXTEND TO UNDISTURBED SUITABLE MATERIAL. (NOTE: CONCRETE IS TO BE KEPT CLEAR OF ALL NUTS, BOLTS, FLANGES, AND JOINTS)

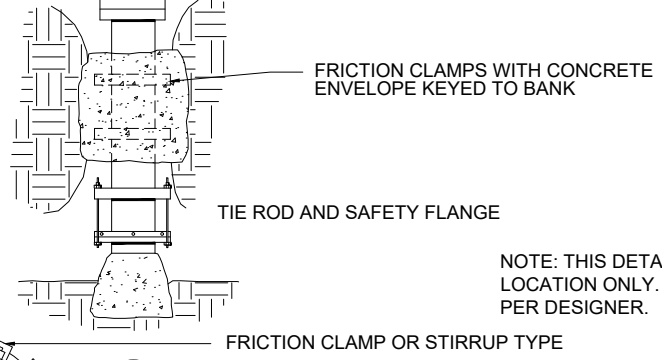

ELEVATION VIEW

WRAP-AROUND STEEL RESTRAINING LOOPS IN CONCRETE KEYPED TO BANK. RESTRAINED GATE AND BEND SHOWN. USE AS DIRECTED.

- NOTES: - ALL NEW PIPE IS TO BE FLUSHED JUST PRIOR TO FINAL CONNECTION AT THE POINT CLOSEST TO THE METER.  
 - NO EXPOSED PIPES ARE TO BE LEFT IN THE GROUND.  
 - ALL CONNECTIONS ARE TO BE LEAK FREE AND MAY BE COMPRESSION TYPE EXCEPT INTERIOR CONNECTIONS WHICH MUST BE FLARED TYPE.

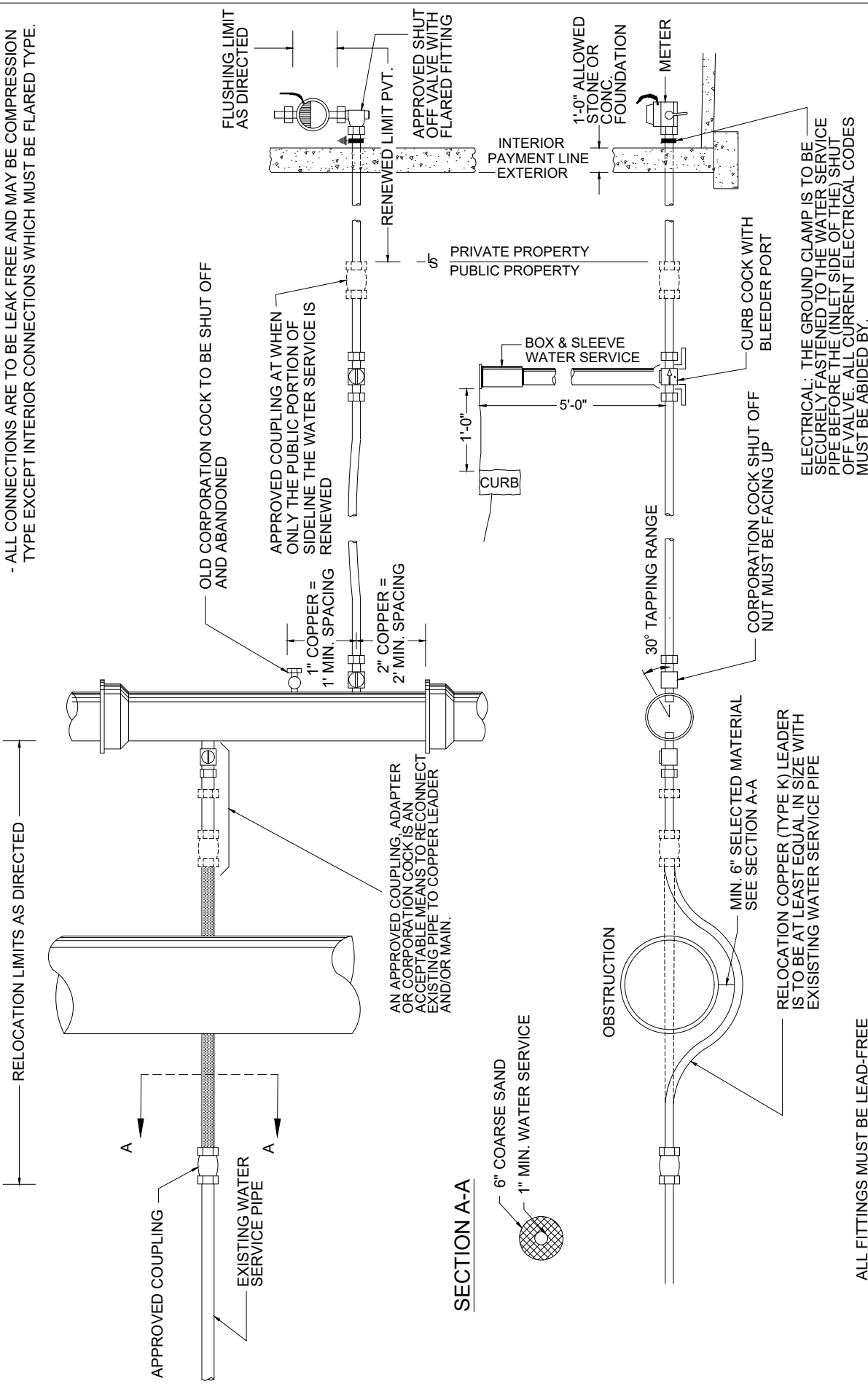

ELECTRICAL: THE GROUND CLAMP IS TO BE SECURELY FASTENED TO THE WATER SERVICE PIPE BEFORE THE (INLET SIDE OF THE) SHUT OFF VALVE. ALL CURRENT ELECTRICAL CODES MUST BE ABIDED BY.

ALL FITTINGS MUST BE LEAD-FREE

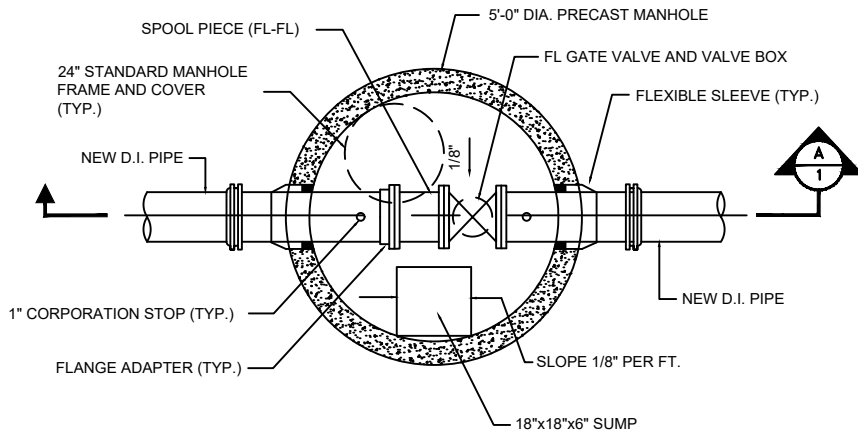

PLAN

- NOTES:**
1. SUMP SHALL HAVE NO COVER.
  2. FULL FACED GASKETS SHALL BE USED ON ALL FLANGES.
  3. ALL D.I. PIPES SHOWN ON THESE DETAIL SHEETS SHALL HAVE RESTRAINED JOINTS.
  4. USE 30" MIN. I.D. CONCRETE RISER SECTION(S) IF DISTANCE FROM TOP OF VAULT TO GROUND SURFACE IS OVER 2 FEET. PARGE INSIDE AND OUTSIDE OF MASONRY/CONCRETE RISERS WITH MORTAR MIX.
  5. PAYMENT LIMITS FOR TRENCH EXCAVATION FOR STRUCTURES SHALL EXTEND TO 18" MAX. FROM THE OUTSIDE WALL/BOTTOM SLAB OF THE STRUCTURE.

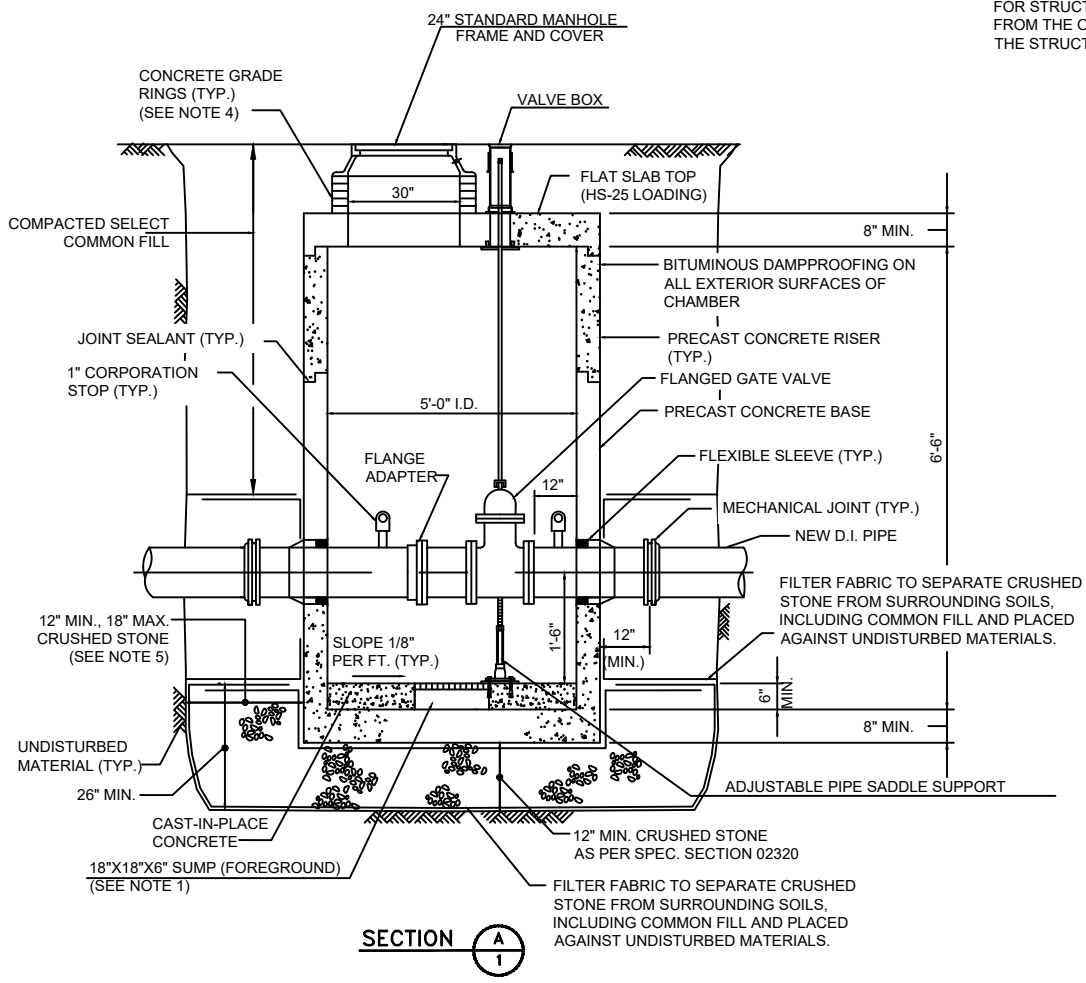

SECTION A-1

8" TO 12": GATE VALVE AND CHAMBER