

THE SURFACE EVIDENCE OF THE UTILITIES SHOWN HAS BEEN LOCATED BY FIELD SURVEY. THE LINework REPRESENTING ALL UNDERGROUND STRUCTURES AND PIPES HAS BEEN SHOWN HEREIN IN ITS APPROXIMATE LOCATION BASED ON AVAILABLE RECORD PLANS. THE SURVEYOR MAKES NO GUARANTEES THAT THE UNDERGROUND UTILITIES SHOWN COMPRISE ALL SUCH UTILITIES IN THE AREA, EITHER IN SERVICE OR ABANDONED. THE SURVEYOR FURTHER DOES NOT WARRANT THAT THE UNDERGROUND UTILITIES SHOWN ARE IN THE EXACT LOCATION INDICATED, ALTHOUGH HE DOES CERTIFY THAT THEY ARE LOCATED AS ACCURATELY AS POSSIBLE FROM INFORMATION AVAILABLE. THE SURVEYOR HAS NOT PHYSICALLY LOCATED THE UNDERGROUND UTILITIES.

- LEGEND**
- UTILITY POLE
 - ⊠ WATER GATE
 - ⊠ GAS GATE
 - ⊠ HYDRANT
 - ⊠ GAS GATE
 - ⊠ SEWER MANHOLE
 - ⊠ DRAIN MANHOLE
 - ⊠ CATCH BASIN
 - TREE
 - LIGHT POLE
 - SIGN
 - TBR TO BE REMOVED
 - TBA TO BE ABANDONED
 - TH# DEEP TEST HOLE
 - PT# PERCOLATION TEST
 - 171.4 X SPOT ELEVATION
 - [] PROPOSED CONTOUR
 - 171 — EXISTING CONTOUR
 - D — DRAIN LINE
 - W — WATER LINE
 - S — SEWER LINE
 - G — GAS LINE
 - X — FENCE
 - STONEWALL
 - HEDGE
 - TREE LINE
 - CO CLEAN OUT
 - TOW TOP OF WALL
 - BOW BOTTOM OF WALL
 - TOC TOP OF CURB
 - BOC BOTTOM OF CURB
 - WW WINDOW WELL

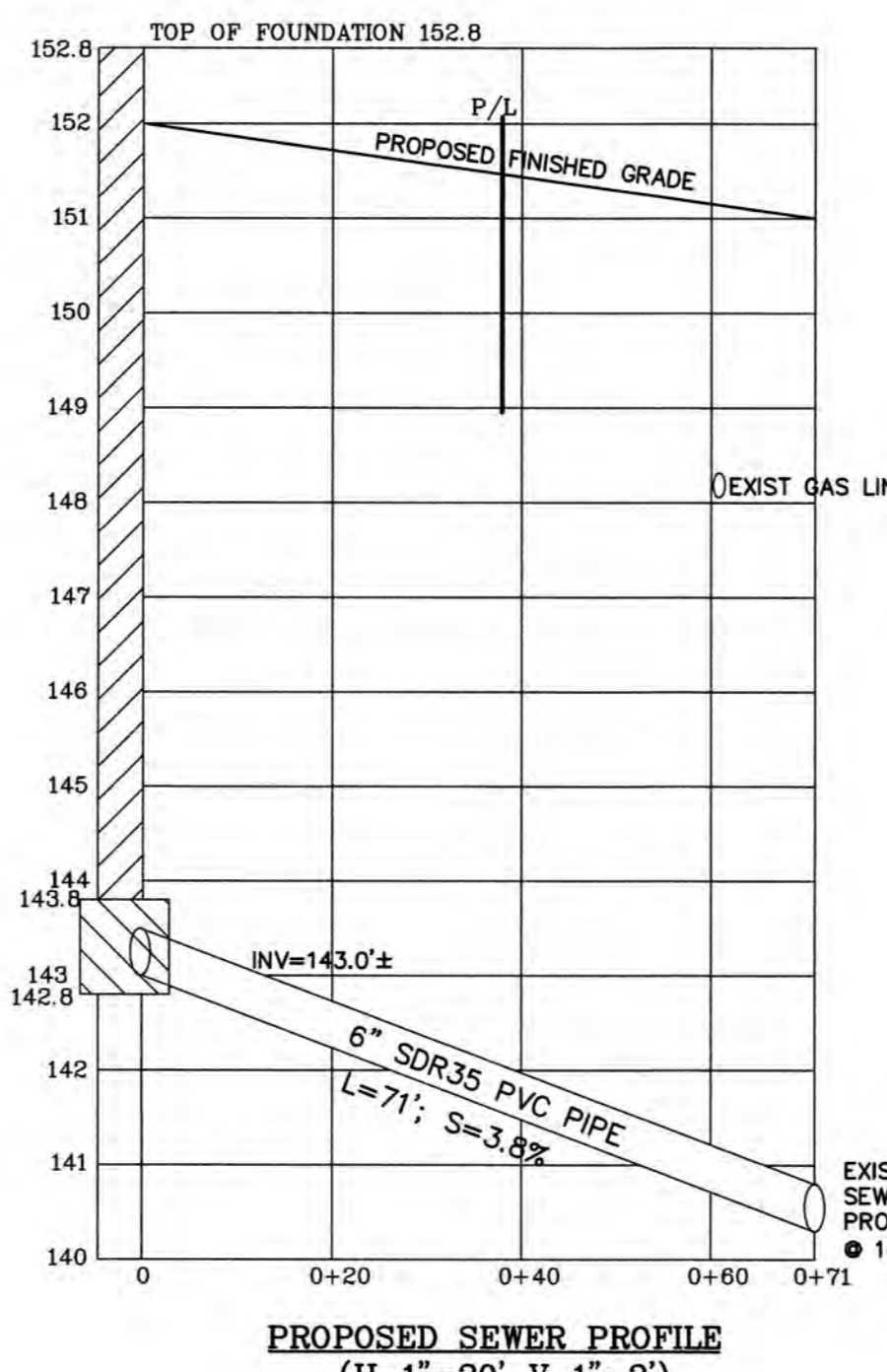
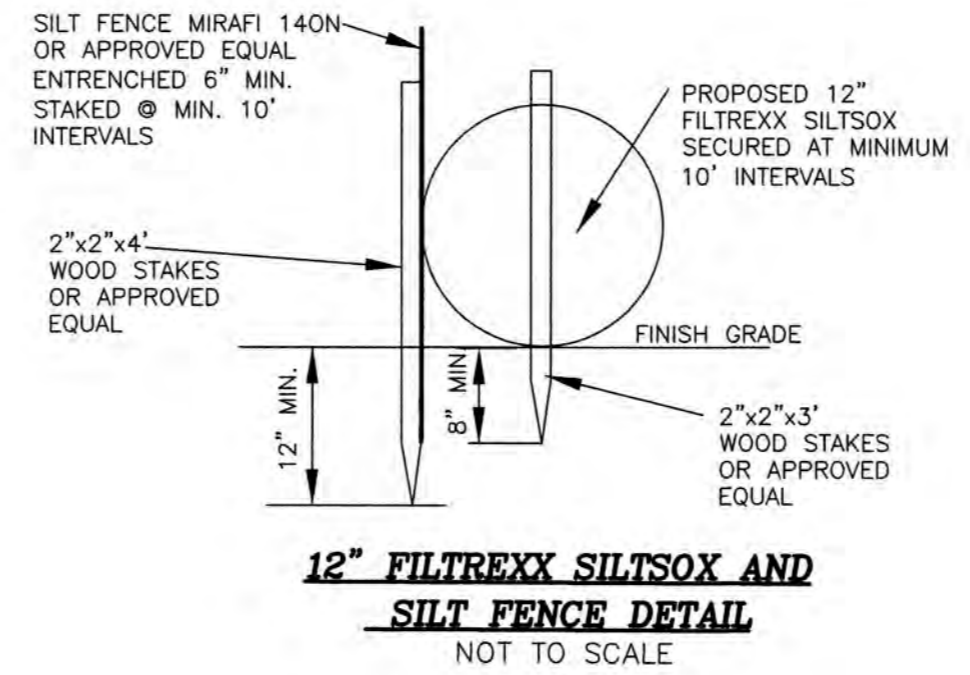

AVERAGE GRADE PLANE

SEGMENT	LENGTH	POINT 1	POINT 2	MEAN 1&2	MEAN X LENGTH
1	42.2	150.9	149.6	150.2	6,338.4
2	41.0	149.6	150.4	150.0	6,150.0
3	12.0	149.6	148.0	149.6	1,795.2
4	20.0	149.8	150.6	150.2	3,004.0
5	22.0	151.0	150.6	150.8	3,317.6
6	21.5	152.0	152.3	152.2	3,272.3
7	8.0	152.3	152.3	152.3	1,218.4
8	10.0	152.3	152.3	152.3	1,523.0
9	15.2	152.3	151.0	151.6	2,304.3
				E=191.9'	E=28,923.2
SUM OF MEAN X LENGTH / SUM OF LENGTHS = AVERAGE GRADE PLANE = 150.72'					

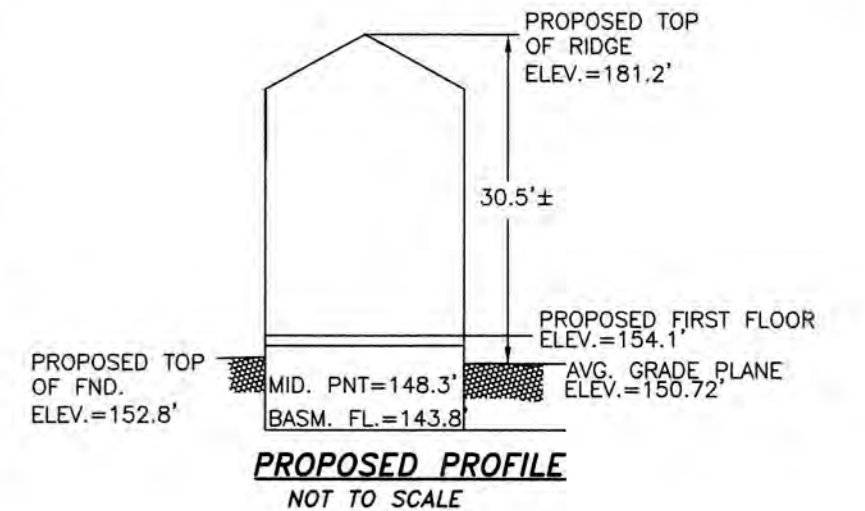

ASSESSOR'S MAP 150 NW SECTION B2 BLOCK 37 LOT 46 NEIGHBORHOOD 4C ZONING - SR3 NEW MINIMUM LOT AREA: 10,000 SF MINIMUM FRONT SETBACK: 30 FT MINIMUM SIDE SETBACK: 10 FT MINIMUM REAR SETBACK: 15 FT MAX LOT COVERAGE: 30% MIN OPEN SPACE: 50%

TREE NUMBER	TREE SPECIES	CIRCUMFERENCE	DBH	STATUS
#1	ARBOVITAE (THUJA OCCIDENTALIS)	28"	9.0	LOCATE AGAINST NORTHEAST HOUSE CORNER
#2	ARBOVITAE (THUJA OCCIDENTALIS)	37"	12.0	LOCATE AGAINST NORTHEAST HOUSE CORNER
#3	ARBOVITAE (THUJA OCCIDENTALIS)	30"	10.0	LOCATE AGAINST NORTHEAST HOUSE CORNER
#4	ARBOVITAE (THUJA OCCIDENTALIS)	34"	11.0	LOCATE AGAINST NORTHEAST HOUSE CORNER
#5	ARBOVITAE (THUJA OCCIDENTALIS)	41"	13.0	ONE OF TWO DYING STEMS
#6	ARBOVITAE (THUJA OCCIDENTALIS)	41"	13.0	ONE OF TWO DYING STEMS
#7	ARBOVITAE (THUJA OCCIDENTALIS)	43"	14.0	MULY-STEM

EXISTING HOUSE 1,491 S.F. INSIDE 100' BUFFER ZONE
 EXISTING HOUSE 283 S.F. INSIDE 50' BUFFER ZONE
 EXISTING DRIVEWAY 352 S.F. INSIDE 100' BUFFER ZONE
 EXISTING PATIO 82 S.F. INSIDE 50' BUFFER ZONE
 EXISTING PATIO 29 S.F. INSIDE 100' BUFFER ZONE

DESIGNED BY:
 MIKHAIL DEYCHMAN
 EMAIL: MDEYCH@YAHOO.COM
 TEL: (857) 498-0951

EXISTING CONDITIONS:
 HOUSE - 1,774 S.F.
 DRIVEWAY - 658 S.F.
 TOTAL: 2,432 S.F.

PROPOSED CONDITIONS:
 HOUSE - 2,225 S.F.
 DRIVEWAY - 854 S.F.
 TOTAL: 3,079 S.F.

INCREASED BY: 647 S.F.

ZONING LEGEND		
ZONING DISTRICT:	REQUIRED	COMPLIANCE
SINGLE RESIDENCE 3 (LOT CREATED AFTER 12/07/1953)		
MIN. AREA	10,000 S.F.	10,830 S.F. ± YES
MIN. FRONTAGE	80'	82.0' YES
MIN. YARD FRONT	30'	30.5' YES
SIDE	10'	11.6' / 11.5' YES
REAR	15'	51.9' YES
MAX. LOT COV.	30%	20.9% ± YES
MIN. OPEN SPACE	50%	70.0% ± YES
MAX. BLDG. HEIGHT	36.0'	30.5' ± YES
MAX. STORIES	2.5	2.5 YES

08/08/22 COMMENTS BY ENGINEERING DEPARTMENT

DATE REVISION

PROPOSED SITE PLAN

71 HARWICH ROAD
 NEWTON, MASSACHUSETTS

RAV & Assoc., Inc.
 21 HIGHLAND AVENUE
 NEEDHAM, MASSACHUSETTS 02021
 TELEPHONE: (781) 449-8200

SCALE: AS NOTED DATE: 07/08/22

APPROVED: DESIGNED BY: DRAWING No. S-2023
 DRAWN BY: SHEET: 1 OF 3

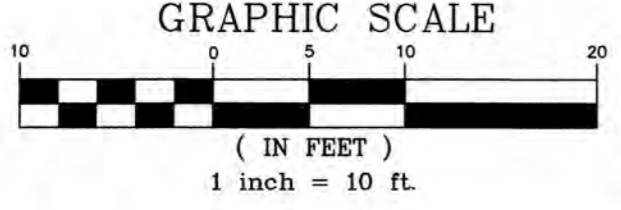

NOTES:

1. ELEVATIONS REFER TO CITY OF NEWTON DATUM.
2. UTILITIES APPROXIMATE AND MUST BE VERIFIED BY THE CONTRACTOR PRIOR TO ANY CONSTRUCTION. THE CONTRACTOR SHALL VERIFY THE LOCATIONS OF ANY CROSSINGS OF PROPOSED AND EXISTING UTILITIES.
3. MASSACHUSETTS STATE LAW REQUIRES UTILITY NOTIFICATION AT LEAST THREE BUSINESS DAYS PRIOR TO CONSTRUCTION. THE CONTRACTOR SHALL CALL DIG-SAFE AT 1-888-344-7233 IN ORDER TO COMPLY WITH STATE LAW.
4. ALL UTILITY CONSTRUCTION SHALL CONFORM TO THE CITY OF NEWTON GENERAL CONSTRUCTION DETAILS, LATEST EDITION, PREPARED AND ISSUED BY THE NEWTON ENGINEERING DEPARTMENT. COPIES MAY BE OBTAINED AT THE OFFICE OF THE CITY ENGINEER. REFER TO NOTE 29 FOR DETAILS.
5. PROPOSED SEWER PIPE SHALL BE 6" PVC SDR 35.
6. PROPOSED WATER SERVICE SHALL BE 1" TYPE K COPPER.
7. THIS PLAN IS THE RESULT OF AN INSTRUMENT SURVEY DONE ON THE GROUND 04/08/2022.
8. ALL WORK SHALL BE SUBJECT TO THE INSPECTION BY AND APPROVAL OF THE CITY ENGINEER.
9. NO EXCAVATION SHALL BE MADE BY THE CONTRACTOR IN ANY PUBLIC WAY OR UTILITY EASEMENT UNLESS AT LEAST FORTY-EIGHT (48) HOURS NOTIFICATION FOR A REQUESTED INSPECTION MUST BE EITHER BY PHONE OR IN PERSON TO THE INSPECTOR ASSIGNED TO YOUR PROJECT, EXCLUSIVE OF SATURDAYS, SUNDAYS, AND HOLIDAYS, BEFORE THE PROPOSED EXCAVATION IS TO BE MADE, HE HAS SUBMITTED WRITTEN NOTICE OF THE PROPOSED EXCAVATION TO THE FOLLOWING:
 - a. SUCH PUBLIC UTILITY COMPANIES AS SUPPLY GAS, ELECTRICITY, AND TELEPHONE SERVICE IN THE CITY.
 - b. SUCH PRIVATE COMPANIES AS PROVIDE CABLE TELEVISION SERVICE IN THE CITY.
 - c. CITY OF NEWTON WATER & SEWER DEPARTMENT.
 SUCH NOTICE SHALL SET FORTH THE STREET NAME AND A REASONABLY ACCURATE DESCRIPTION OF THE LOCATION OF THE EXCAVATION.
10. THE CONTRACTOR SHALL PROVIDE CITY OF NEWTON POLICE OFFICERS FOR THE DIRECTION AND CONTROL OF TRAFFIC, AS REQUIRED BY THE CITY ENGINEER.
11. NO WORK SHALL BE PERFORMED UNTIL THE NECESSARY PERMITS ARE OBTAINED FROM THE CITY OF NEWTON PUBLIC WORKS DEPARTMENT.
12. ALL TRENCHES IN PAVED STREETS SHALL MATCH EXISTING ASPHALT THICKNESS, LAID HOT AND MAINTAINED UNTIL THE PERMANENT PATCH IS INSTALLED OR AS DIRECTED BY ENGINEERING INSPECTOR.
13. WARNING SIGNS SHALL CONFORM REFER TO THE 2020 MUTCD STANDARD HIGHWAY SIGNS.
14. ALL TOPSOIL, SUBSOIL OR IMPERVIOUS SOIL MUST BE EXCAVATED AND REMOVED BELOW THE LEACHING SYSTEM AND IN ALL DIRECTIONS BEYOND THE SIDES OF THE GALLEYS. BACKFILL AS REQUIRED WITH A CLEAN GRANULAR SAND, FREE FROM ORGANIC MATTER AND DELETERIOUS SUBSTANCES. THE SAND SHALL HAVE A PERCOLATION RATE OF 2 MINUTES PER INCH OR FASTER.
15. IN CASES WHERE LEDGE OR BOULDERS ARE ENCOUNTERED, RAV & ASSOCIATES, INC. WILL NOT BE RESPONSIBLE FOR THE AMOUNT OF ROCK ENCOUNTERED.
16. IF ANY MODIFICATIONS TO THE APPROVED PLAN ARE COMPLETED/UNDERTAKEN WITHOUT A REVISED "STAMPED" DESIGN PLAN BEING RECEIVED FROM THE DESIGN ENGINEER FOR REVIEW BY THE ENGINEERING DIVISION, ALL WORK OF THAT PHASE OF THE PROJECT SHALL STOP. NO ADDITIONAL INSPECTIONS FOR THAT PHASE OF THE PROJECT WILL BE CONDUCTED BY THE ENGINEERING INSPECTOR UNTIL THE REVISED "STAMPED" PLAN IS APPROVED.
17. THE ROOF RUNOFF FROM THE ROOF SURFACES SHALL BE COLLECTED BY GUTTERS AND DIRECTED TO THE STORM WATER DRAINAGE SYSTEM.
18. ANY PROPOSED PVC PIPES UNDER PAVING OR CONCRETE WITH LESS THAN 30" OF COVER MUST BE ENCASED IN CONCRETE. (SEE PAGE 21, CITY OF NEWTON GENERAL CONSTRUCTION DETAILS.)
19. THE EXISTING WATER & SEWER SERVICES SHALL BE CUT AND CAPPED AT THE MAIN AND BE COMPLETELY REMOVED FROM THE SITE, REPLACED AS SPECIFIED AND PROPERLY BACKFILLED. THE ENGINEERING DIVISION MUST INSPECT THIS WORK; FAILURE TO HAVE THIS WORK INSPECTED MAY RESULT IN THE DELAY OF ISSUANCE OF THE UTILITY CONNECTION PERMIT.
20. THE CONTRACTOR SHALL NOTIFY THE ENGINEERING DIVISION 48 HOURS IN ADVANCE AND SCHEDULE AN APPOINTMENT TO HAVE THE DRAINAGE SYSTEM, WATER & SEWER SERVICES INSPECTED. THE SYSTEM & UTILITIES MUST BE FULLY EXPOSED FOR THE INSPECTOR. ONCE THE INSPECTOR IS SATISFIED, THE SYSTEM & UTILITIES MAY THEN BE BACKFILLED.
21. NO WORK IS ALLOWED WITHIN A CITY OF NEWTON RIGHT-OF-WAY BETWEEN NOVEMBER 15TH AND APRIL 15TH, IF AN EMERGENCY EXISTS OR THERE ARE EXTENUATING CIRCUMSTANCES, APPLICANT MAY REQUEST PERMISSION FROM THE CITY ENGINEER. IF ALLOWED, SPECIAL CONSTRUCTION REQUIREMENTS WILL BE REQUIRED, AND AS SUCH IT IS RECOMMENDED THAT THE APPLICANT OR APPLICANT'S REPRESENTATIVE CONTACT THE CITY OF NEWTON ENGINEERING DEPARTMENT PRIOR TO START OF WORK FOR CLARIFICATION.
22. AT THE END OF CONSTRUCTION, ALL DRAINAGE STRUCTURES ARE TO BE CLEANED OF SILT, STONES AND OTHER DEBRIS.
23. DURING CONSTRUCTION, THE EROSION CONTROL MEASURES SHALL BE INSPECTED ONCE PER WEEK AND WITHIN 24 HOURS OF ANY STORM EVENT GENERATING MORE THAN 1/2" OF RAINFALL. THE EROSION CONTROL MEASURES SHALL BE CLEANED REGULARLY AND ADJUSTED IF NECESSARY TO ENSURE THAT NO SILT OR DEBRIS LEAVES THE SITE.
24. WITH EXCEPTION OF GAS UTILITY SERVICES, ALL UTILITY TRENCHES WITHIN ANY CITY OF NEWTON RIGHT-OF-WAY WILL BE BACKFILLED WITH TYPE IE (EXCAVATABLE) CONTROLLED DENSITY FILL, AS SPECIFIED BY THE CITY OF NEWTON ENGINEERING SPECIFICATIONS.
25. ALL CONSTRUCTION ACTIVITIES WITHIN THE CITY OF NEWTON RIGHT-OF-WAY MUST FULLY COMPLY WITH ALL OF CITY OF NEWTON CONSTRUCTION SPECIFICATIONS AS WELL AS 521 CMR 21.00 AND 22.00.
26. THE NEW SEWER SERVICE AND/OR STRUCTURES SHALL BE PRESSURE TESTED OR VIDEOTAPED AFTER FINAL INSTALLATION IS COMPLETE. METHOD OF FINAL INSPECTION SHALL BE DETERMINED SOLELY BY THE ENGINEERING INSPECTOR FROM THE CITY OF NEWTON. ALL SEWER MANHOLES SHALL BE VACUUM TESTED IN ACCORDANCE WITH CITY OF NEWTON SPECIFICATIONS. THE SEWER SERVICE WILL NOT BE ACCEPTED UNTIL ONE OF THE TWO METHODS STATED ABOVE IS COMPLETED. ALL TESTING MUST BE WITNESSED BY A REPRESENTATIVE OF THE ENGINEERING DIVISION.
27. ALL SILTATION CONTROL NEEDS TO BE INSTALLED PRIOR TO ANY CONSTRUCTION. THE CONTRACTOR SHALL CONTACT THE CITY ENGINEER'S OFFICE FOR APPROVAL PRIOR TO COMMENCEMENT.
28. ALL TRENCH EXCAVATION CONTRACTORS SHALL COMPLY WITH MGL CHAPTER 82A, TRENCH EXCAVATION SAFETY REQUIREMENTS, TO PROTECT THE GENERAL PUBLIC FROM UNAUTHORIZED ACCESS TO UNATTENDED TRENCHES. A TRENCH EXCAVATION PERMIT IS REQUIRED. THIS APPLIES TO UNATTENDED TRENCHES.
29. CIVIL ENGINEER BASED DESIGN ON PROVIDED SURVEY. ENGINEER NOT RESPONSIBLE FOR ANY DISCREPANCY IN THE PROVIDED SURVEY.
30. CONTRACTOR TO ENSURE SEWER LINE IS PITCHED AT AN EQUAL SLOPE OF BETWEEN 2% AND 10% FROM HOUSE TO MAIN CONNECTION.
31. CONTRACTOR TO CONFIRM LOCATION OF DOWNSPOUTS PRIOR TO CARRYING OUT ANY DRAINAGE WORKS.
32. RAV & ASSOCIATES INC, ACCEPT NO LIABILITY FOR GROUND WATER OR OTHER SURFACE WATER IN BASEMENT
33. SEWER AND WATER MAIN LOCATION TO BE CONFIRMED BY CONTRACTOR
34. SURFACE WATER TO BE DIVERTED FROM ALL SIDES OF FOUNDATION WALL
35. ANY TREE BEING REMOVED SHALL COMPLY WITH CITY OF NEWTON TREE ORDINANCE
36. CONTRACTOR TO ENSURE THAT THE BUILDING FOOTPRINT REPRESENTED ON THIS PLAN IS THE SAME AS THE PROPOSED ARCHITECTURAL /STRUCTURAL PLANS AND INCORPORATES ALL OVERHANGS, CANTILEVERS AND ANY COMPONENT THAT IS SUBJECT TO ZONING RESTRICTIONS. IF THIS IS FOUND NOT TO BE THE CASE THE CONTRACTOR MUST CONTACT THE ENGINEER /SURVEYOR AND REQUEST A REVISED PLAN WHICH MUST BE RESUBMITTED TO I.S.D. CITY OF NEWTON
37. PER CITY OF NEWTON ORDINANCE NO. B-52, COUNCIL ITEM #251-19, BUILDING SEWER, WATER SERVICE PIPE AND SIDEWALK/CURB REPLACEMENT ORDINANCE. THE APPLICANT IS REQUIRED TO INSTALL/REPLACE SIDEWALK AND CURB ALONG THE ENTIRE FRONTAGE. THIS SHALL INCLUDE APPROPRIATE TRANSITION TO ADJOINING CURBING AND WALKWAYS, INCLUDING ACCESSIBLE CURB CUTS AND OTHER ACCESS AS REQUIRED. THE ENGINEERING CONSTRUCTION INSPECTOR MAKES A DETERMINATION, BASED ON THE MATERIAL AND MANNER OF CONSTRUCTION OF THE EXISTING SIDEWALK AND CURB, IF THE EXISTING SIDEWALK AND CURB HAS THE ABILITY TO BE REUSED WITHOUT REPLACEMENT.
38. ANY WALL IN EXCESS OF 4- FEET OR TALLER MUST BE DESIGNED BY A STRUCTURAL ENGINEER LICENSED IN MASSACHUSETTS. A QUALIFIED PE CAN DESIGN A RETAINING WALL NOT JUST A STRUCTURAL PE.

39. THE ENGINEER OF RECORD IS RESPONSIBLE FOR THE ON-SITE INSPECTION(S) OF ALL SUBSURFACE STRUCTURES. THIS INCLUDES BUT IS NOT LIMITED TO DRAINAGE, UTILITIES, (INCLUDING SEWER PIPE SLOPE), ROOF LEADER COLLECTION SYSTEM, TRENCH DRAINS, MANHOLES, ETC. ENGINEER OF RECORD MUST ALSO CONDUCT "BOTTOM OF HOLE" INSPECTION(S) PRIOR TO SUBSURFACE DRAINAGE SYSTEM(S) BEING INSTALLED.

40. PRIOR TO AN OCCUPANCY PERMIT BEING ISSUED, AN AS-BUILT PLAN MUST BE SUBMITTED TO THE ENGINEERING DIVISION IN BOTH DIGITAL FORMAT AND HARD COPY. THE PLAN SHOULD SHOW ALL UTILITIES AND FINAL GRADES, TIES TO ALL GATES, VALVES, CLEAN-OUTS, CONNECTION POINTS AT MAINS, STRUCTURE ACCESS/MAINTENANCE COVERS, ANY EASEMENTS AND FINAL GRADING.

PRIOR TO THE ENGINEERING DIVISION RECOMMENDING THAT A CERTIFICATE OF OCCUPANCY BE ISSUED, AN AS-BUILT PLAN MUST BE SUBMITTED. THE AS-BUILT PLAN MUST SHOW DIMENSIONAL TIES FROM FIXED POINTS (FOUNDATION CORNERS) TO ALL SUBSURFACE COMPONENTS AS WELL AS FINAL GRADING. THE AS-BUILT PLAN MUST BE STAMPED, SIGNED AND DATED BY THE ENGINEER OF RECORD.

THIS NOTE MUST BE ON ALL AS-BUILT PLANS:

I CERTIFY THAT THE CONSTRUCTION SO SHOWN WAS INSPECTED PRIOR TO BACKFILL AND THAT ALL WORK CONFORMS WITH THE APPROVED PLAN AND MEETS OR EXCEEDS THE CITY OF NEWTON CONSTRUCTION STANDARDS.

I CERTIFY THAT THE CONSTRUCTION SHOWN WAS INSPECTED PRIOR TO BACKFILL AND THAT ALL WORK CONFORMS WITH APPROVED PLAN
SIGNATURE _____ DATE _____

41. IF AT TIME OF CONSTRUCTION THE ROADWAY FALLS UNDER A 5-YEAR CONSTRUCTION MORATORIUM, THE ROADWAY WILL BE MILLED CURB TO CURB FOR A DISTANCE OF 25 FEET FROM THE OUTER MOST TRENCHES AND PAVED WITH BITUMINOUS CONCRETE.

42. CONTRACTOR HAS TO STABILIZE SLOPE DURING CONSTRUCTION.

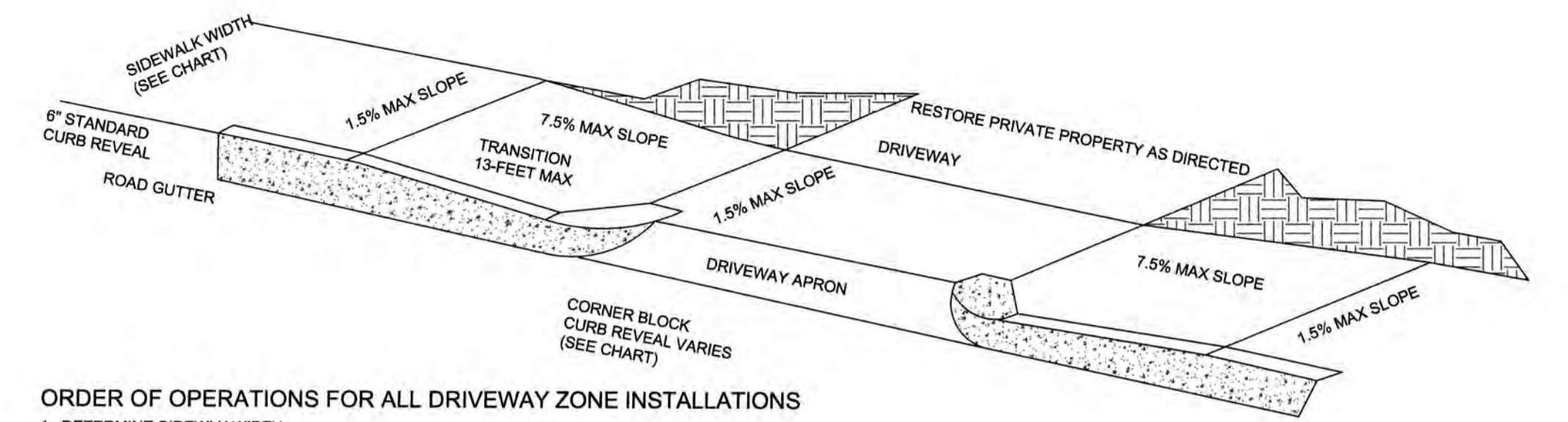

ORDER OF OPERATIONS FOR ALL DRIVEWAY ZONE INSTALLATIONS

1. DETERMINE SIDEWALK WIDTH
2. SET THE CORNER BLOCK REVEAL TO THE DIMENSIONS SHOWN ON THE CHART BELOW AND INSTALL THE TRANSITION CURB.
3. LOCATE THE INTERCEPT AXIS AND RE-CHECK FOR THE MINIMUM ACCESSIBLE ROUTE WIDTH.
4. SET THE 1.5% GRADIENT TO THE BACK OF THE WALK WITH A 2" SMART LEVEL AND RIGID STRAIGHTEDGE.
5. FINE GRADE THE APRON AREA WHILE MAINTAINING THE INTERCEPT AXIS AND BACK OF SIDEWALK GRADE POINTS.
6. CHECK THE FORMS, HOWEVER, THE CONTRACTOR MUST USE A 2" SMART LEVEL DURING OPERATIONS TO ENSURE THAT THE FINAL LINE AND GRADE COMPLIES WITH THE NOTED DIMENSIONS AND/OR GRADIENTS.
7. DURING THE FINISHING OPERATIONS OF THE CEMENT CONCRETE, THE CONTRACTOR IS TO CHECK THE FINAL PRODUCT(S) TO ENSURE CONTINUED COMPLIANCE WITH THE NOTED STANDARDS.

DRIVEWAY TRANSITIONS TO INTERCEPT 6" STD CURB REVEAL (TARGET VALUES ONLY) (1)

DRIVEWAY	CORNER BLOCK REVEAL	DISTANCE TO APRON INTERCEPT	RISE TO APRON INTERCEPT	GUTTER GRADE (2)	HIGH SIDE LENGTH TO TRANSITION CURB INCLUDING THE 2' RADIUS COR. BLK. (3)(4)
4'-6"	3'-5 1/2" MAX	1'-6" FIXED	3'-5 1/2" MAX	UP TO 0.5	4'-0"
				1	4'-0"
				2	4'-0"
				3	5'-0"
				4	6'-0"
				5	8'-0"
				7 & GREATER	10'-0" MAX

DRIVEWAY APRONS

IMPORTANT NOTE (APPLICABLE TO ALL CURB AND DRIVEWAYS)
ALL DIMENSIONAL INFORMATION IS FOR PLANNING PURPOSES ONLY. THE FINAL PRODUCTS ROUTE CRITERIA PER THE RULES AND REGULATIONS OF THE MASSACHUSETTS ARCHITECTURAL ACCESS BOARD AND THE AMERICAN DISABILITIES ACT.

- (1) FINAL PRODUCT(S) MUST NOT EXCEED THE 7.5 % GRADIENT OR 1.5% CROSS SLOPE STANDARDS.
- (2) WHEN THE FACTOR FALLS BETWEEN THE LISTED RANGE, USE THE LESSER GRADIENT FACTOR.
- (3) THE MAXIMUM REQUIRED TRANSITION LENGTH OF CURB IS 15'-0"
- (4) SIDEWALKS WITH LOAM BORDERS DO NOT REQUIRE TRANSITION CURBS.

DRIVEWAY APRON DETAIL

NOT TO SCALE

DESIGNED BY:
MIKHAIL DEYCHMAN
EMAIL: MDEYCH@YAHOO.COM
TEL. (857) 498-0951

08/08/22	COMMENTS BY ENGINEERING DEPARTMENT
DATE	REVISION

NOTES

**71 HARWICH ROAD
NEWTON, MASSACHUSETTS**

RAV & Assoc., Inc.
21 HIGHLAND AVENUE
NEEDHAM, MASSACHUSETTS 02021
TELEPHONE: (781) 449-8200

SCALE: AS NOTED DATE: 07/08/22

APPROVED:	DESIGNED BY: DRAWN BY:	DRAWING No. S-2023 SHEET: 2 OF 3
-----------	---------------------------	--



